

Uncertainty Determinants of Corporate Liquidity

Christopher F. Baum*

Department of Economics
Boston College

Mustafa Caglayan

Department of Economics
University of Leicester

Andreas Stephan

DIW – Berlin
Europa-Universität Viadrina

Oleksandr Talavera

DIW – Berlin
Europa-Universität Viadrina

31st January 2005

*The standard disclaimer applies. We gratefully acknowledge comments and helpful suggestions by Christopher F. Baum and Yuriy Gorodnichenko. Corresponding author: Oleksandr Talavera, tel. (+49) (0)30 89789 207, fax. (+49) (0)30 89789 200, e-mail: otalavera@diw.de, mailing address: Königin-Luise-Str. 5, 14195 Berlin, Germany.

Uncertainty Determinants of Corporate Liquidity

Abstract

This paper investigates the link between the optimal level of non-financial firms' liquid assets and uncertainty. We develop a partial equilibrium model of precautionary demand for cash that shows that firms are likely to change their liquidity ratio in response to changes in uncertainty. We test this proposition using a panel of non-financial US firms drawn from COMPUSTAT quarterly database covering the period 1991-2001. The results show that firms increase their liquidity ratios when macroeconomic uncertainty increases. We demonstrate that our results are robust with respect to the inclusion of detrended index of leading indicators and interest rates.

Keywords: cash, uncertainty, non-financial firms, dynamic panel data.

JEL classification C23, D8, D92, G32.

1 Introduction

“As a result of the foregoing, Honda’s consolidated cash and cash equivalents amounted to ¥547.4 billion as of March 31, 2003, a net decrease of ¥62.0 billion from a year ago. ... Honda’s general policy is to provide amounts necessary for future capital expenditures from funds generated from operations. With the current levels of cash and cash equivalents and other liquid assets, as well as credit lines with banks, Honda believes that it maintains a sufficient level of liquidity.”¹

“Standard & Poor’s said those reserves have declined severely over the last year and blamed the drain, in part, on Schrempp’s massive spending spree, which included taking a 34 percent stake in debt-ridden Japanese automaker Mitsubishi Motors. According to an article in Newsweek magazine, DaimlerChrysler’s cash reserves – a cushion against any economic turndown – will dwindle to \$ 2 billion by the end of the year, down 78 percent from two years ago. That compares with cash reserves of more than \$13 billion at rivals General Motors and Ford, the magazine said.”²

Why is it considered so good when a company is able to maintain considerable amounts of cash like in Honda’s case? Why is it so bad when cash reserves go down as in DaimlerChrysler’s case? What determines the optimal level of liquidity? In the seminal paper of Modigliani and Miller (1958) cash is considered as a zero net present value investment. There are no benefits from holding cash in a world without information asymmetries, transaction costs, or taxes, and with perfect capital markets.

However, the real world is imperfect and firms can avoid some costs by holding liquid assets. Keynes (1936) suggests two main reasons of maintaining a positive level of liquid assets. First, firms hold liquid assets to reduce transaction costs. Second, cash stock provide a buffer to meet unexpected contingencies. Managers can increase

¹Citation. <http://world.honda.com/investors/annualreport/2003/17.html>

²Citation. <http://www.detnews.com/2000/autos/0012/04/-157334.htm>

firm value by managing their cash balances. This cash buffer allows the company to maintain the ability to invest when the company does not have sufficient current cash flows to meet investment demands.

There is great variation in liquidity ratios among different types of firms which is systematically related to firm size, industry, and leverage ratios. Econometric analysis in the recent literature suggests that liquid assets are positively correlated with proxies for agency problems. Therefore, firms cannot borrow easily and maintain higher levels of cash to finance investment opportunities. For instance, BMW Group invested 2,807 million Euro in 1999 and these investment were financed in full out of the Group's cash flow.³ The link between cash flow and investment has been often investigated in the literature (Fazzari, Hubbard and Petersen (1988), Schnure (1998), Cummins, Hasset and Oliner (1995), Charlton, Lancaster and Stevens (2002)). Kim and Sherman (1998) argue that firms increase investment in liquid assets in response to increase in the cost of external financing, the variance of future cash flows, and the return on future investment opportunities. Moreover, they document that larger firms tend to have lower ratios of cash to assets.⁴ Additionally, Harford (1999) argues that corporations with excessive cash holdings are less likely to be takeover targets.

In an important recent paper, Almeida, Campello and Weisbach (2004) develop a liquidity demand model where firms have access to investment opportunities but cannot finance them. In a world without financial constraints cash holdings are irrelevant and firms undertake all positive NPV projects regardless of cash position. However, when firms have financial constraints they have an optimal level of liquid assets, determined through equating marginal costs of cash holdings to marginal benefits of cash holdings.⁵

³Citation. BMW Annual Report 1999. http://www.autointell-news.com/european_companies/BMW/business-figures/bmw-annual-1999.htm

⁴See also Opler, Pinkowitz, Stulz and Williamson (1999), Mills, Morling and Tease (1994).

⁵See also Bruinshoofd (2003).

The idea of a precautionary demand for cash is further explored by Myers and Majluf (1984). They argue that firms facing information asymmetry-induced financial constraints are likely to accumulate cash holdings. In the recent paper Baum, Caglayan, Ozkan and Talavera (2002) develop a static model of cash management with a signal extraction mechanism. It shows a positive relationship between cash holdings, the interest rate on loans, and levels of uncertainty. Moreover, they find that firms behave similarly in response to increases in macroeconomic uncertainty.⁶

The purpose of this paper is to provide a theoretical and empirical investigation of the firm's decision to hold liquid assets. Furthermore, we attempt to bridge the gap in existing research by matching firm-specific data with information on their macroeconomic environment. This matching allows us to investigate whether both macroeconomic and idiosyncratic uncertainties have effects on cash holdings.

We present a model that formalizes the precautionary demand for cash.⁷ The firm maximizes its assets by investing funds and holding cash to offset an adverse cash flow shock distributed according to triangular distribution with fixed bounds. The optimal level of cash holdings is derived as a function of expected return on investment, the expected interest rate on loans, the bounds of cash flow distribution, the probability of getting a loan, and initial wealth. After parametrization we anticipate that managers change levels of liquidity in response to changes in uncertainty.

For testing this prediction we utilize a panel of non-financial firms obtained from the quarterly COMPUSTAT database over the 1991–2001 period. After screening procedures our data include more than 30,000 manufacturing firm-year observations, with 700 firms per quarter. We also consider a sample split, defining categories of durable-goods makers vs. non-durable goods makers. We apply one- and two-step

⁶In a recent paper Bo (1999) suggests that presence of uncertainty factors changes the structural parameters of the Q-model of investment.

⁷The model ignores the transaction motive for holding cash, and the optimal amount of liquid assets is zero in the absence of costly external financing.

system GMM estimators (Arellano and Bond, 1991).

Our main findings can be summarized as follows. We find evidence of a positive association between the optimal level of liquidity and macroeconomic uncertainty, proxied by the conditional variance of industrial production. US companies also increase their liquidity ratios when idiosyncratic uncertainty increases. The results differ for durable and non-durable goods-makers. While macroeconomic uncertainty does matter for the former group, we do not observe statistically significant effects for the latter group. The durable goods-makers also have a higher sensitivity to idiosyncratic uncertainty. The results are shown to be robust to the inclusion of such macroeconomic variables as index of leading indicators and interest rates.

The remainder of the paper is organized as follows. Section 3.2 discusses the theoretical model of firms' precautionary demand for liquid assets. Section 3.3 describes our data and empirical results. Finally, Section 3.4 concludes.

2 Theoretical Model

2.1 Model Setup

We develop a simple cash buffer-stock model, where a firm manager maximizes assets of the firm in the next period. This framework allows the manager to vary optimal level of liquid assets in response to idiosyncratic and/or macroeconomic uncertainty.

The model has two periods, t and $t + 1$. At time t the firm has wealth W_{t-1} that comes either from stock issue if the firm has been just established or from the previous period's activity. At time t the initial wealth W_{t-1} has to be distributed between investment (I_t) and cash holding (C_t).⁸ For simplicity, the firm does not finance any other activities. Investment is expected to earn $E[R]_{t+1}$, the gross return

⁸The term *Cash holdings* may include not only cash itself but also low-yield liquid assets, e.g. Treasury Bills.

in the time $t + 1$.⁹ Liquid asset holdings, C_t , are required to guard against negative shock.

Between periods t and $t + 1$ the firm faces a cash-flow shock ψ_t , distributed according to a symmetric triangular distribution with mean zero and defined on the range $\psi_t \in [-H_t, H_t]$.¹⁰ In our framework H_t serves as a measure of uncertainty faced by firm. There are three possible cases.

First, there is a positive cash-flow shock that occurs with probability p_1 and has conditional expectation $\psi_{t,1}$:

$$\begin{aligned} p_1 &= \Pr(\psi_t > 0) = \frac{1}{2} \\ \psi_{t,1} &= E(\psi_t | \psi_t > 0) = H_t \left(1 - \frac{\sqrt{2}}{2}\right) \end{aligned}$$

The firm's wealth in this case is

$$W_{t+1,1} = I_t E[R]_{t+1} + C_t + \psi_{t,1} = I_t E[R]_{t+1} + C_t + H_t \left(1 - \frac{\sqrt{2}}{2}\right) \quad (1)$$

Second, there is a negative cash-flow shock, but the firm has enough liquid assets to cover it. This shock occurs with probability p_2 and has conditional expectation $\psi_{t,2}$:

$$\begin{aligned} p_2 &= \Pr(0 > \psi_t > -C_t) = \frac{1}{2} \frac{C_t(2H_t - C_t)}{H_t^2} \\ \psi_{t,2} &= E(\psi_t | 0 > \psi_t > -C_t) = -C_t \left(1 - \frac{\sqrt{2}}{2}\right) \end{aligned}$$

In this notation the assets of the firm in the case when $0 > \psi_t > -C_t$ are equal to

$$W_{t+1,2} = I_t E[R]_{t+1} + C_t + \psi_{t,2} = I_t E[R]_{t+1} + C_t \frac{\sqrt{2}}{2} \quad (2)$$

⁹For simplicity we assume that distribution of return is independent from all other variables' distributions.

¹⁰The triangular distribution is chosen as an approximation to the normal distribution, which would require evaluation of nonlinear function.

Finally, there is the situation when the firm does not have enough liquid assets to cover negative cash–flow shock. This event occurs with probability p_3 and has conditional expectation $\psi_{t,3}$:

$$\begin{aligned} p_3 &= \Pr(-C_t > \psi_t) = \frac{H_t^2 - 2H_t C_t + C_t^2}{2H_t^2} \\ \psi_{t,3} &= E(\psi_t | -C_t > \psi_t) = -H_t + \frac{\sqrt{2}}{2}(H_t - C_t) \end{aligned}$$

In this case the firm must seek external finance and borrow $-(\psi_t + C_t)$ at the rate X_t . However, there is probability s_t that the firm gets the funds, otherwise it declares bankruptcy and its wealth at time two is equal to zero.¹¹ For simplicity we assume that the probability of getting external funds is independent of the distribution of cash–flow shocks. The assets of the firm in the last case are equal to

$$\begin{aligned} W_{t+1,3} &= s_t (I_t E[R]_{t+1} + C_t + \psi_{t,3} - X_t(\psi_{t,3} + C_t)) + (1 - s_t)0 = \\ &= s_t \left[I_t E[R]_{t+1} - (1 + X_t)(H_t - C_t) \left(1 - \frac{\sqrt{2}}{2} \right) \right] \end{aligned} \quad (3)$$

We denote $I_t = W_{t-1} - C_t$. Given all three possible cases, the objective is to maximize the expected wealth (asset value) of the firm in period $t + 1$. The firm's problem can be written as

$$\begin{aligned} \max_{C_t} (E(W_{t+1})) &= \max_{C_t} (p_1 W_{t+1,1} + p_2 W_{t+1,2} + p_3 W_{t+1,3}) = \\ &= \max_{C_t} \left(\frac{1}{2} \left((W_{t-1} - C_t) E[R]_{t+1} + C_t + H_t \left(1 - \frac{\sqrt{2}}{2} \right) \right) \right) \\ &+ \frac{1}{2} \frac{C_t(2H_t - C_t)}{H_t^2} \left((W_{t-1} - C_t) E[R]_{t+1} + C_t \frac{\sqrt{2}}{2} \right) \\ &+ \frac{(H_t - C_t)^2 s_t}{2H_t^2} \left((W_{t-1} - C_t) E[R]_{t+1} - (1 + X_t)(H_t - C_t) \left(1 - \frac{\sqrt{2}}{2} \right) \right) \end{aligned} \quad (4)$$

¹¹For instance, firm has fire accident at production line. Then it does not have funds to replace equipment and all investment vanishes.

which is our objective function and C_t , optimal level of cash holdings, is the only choice variable.

The first order condition imply that the optimal cash has to be¹²

$$C_t = \frac{1}{3} \frac{(2.83 - 1.75s_t)H_t + 1.75s_tX_tH_t - 2E[R]_{t+1}(1 - s_t)(2H_t + W_{t-1}) + \sqrt{D}}{1.41 - 0.59s_t - 2(1 - s_t)E[R]_{t+1} + 0.58s_tX_t} \quad (5)$$

The solution is not linear and we linearize it around equilibrium levels.

$$\hat{C}_t = \alpha_1 \hat{W}_{t-1} + \alpha_2 \hat{R}_{t+1} + \alpha_3 \hat{H}_t + \alpha_4 \hat{X}_t + \alpha_5 \hat{s}_t \quad (6)$$

where coefficients $\alpha_1 - \alpha_5$ depend on model parameters. The expected signs of the coefficients are discussed in the following subsection.

2.2 Model solution discussion

The analytical solution for the optimal cash holdings is a non-linear function of the initial wealth, W_{t-1} ; the expected gross return on investment, $E[R]_{t+1}$; the gross interest rate for borrowing, X_t ; the bounds of the triangular distribution of cash shocks, H_t and probability of getting a credit when negative shock is higher than available cash holdings, s_t . The implicit solution is a complicated function of the model parameters. We cannot obtain comparative static results but we may employ graphical analysis to determine the signs of α , the parameters in equation 6.

Figure 1 presents the relationship among optimal cash holding and interest rate for external borrowing and bounds of cash shock distribution. If we take $W_{t-1} = 30$, $E[R]_{t+1} = 1.2$ then the level of cash increases if H_t increases from 5 to 25. Moreover, the company holds more cash (17 out of 30 for $H_t = 25$ and $s_t = 0$; 13 out of 30 for

¹² D is a function $f(E[R]_{t+1}, X_t, s_t, H_t, W_{t-1})$

$$D = (16.49 - 6s_t + 6s_tX_t)H_t^2 - (43.11 - 33.17s_t + 7.03s_tX_t)E[R]_{t+1}H_t^2 + 4(1 - s_t)^2E[R]_{t+1}^2W_{t-1}^2 + (4s_t^2 - 32s_t + 28)E[R]_{t+1}^2H_t^2 - 8(1 - s_t)^2E[R]_{t+1}^2W_{t-1}H_t + 5.66(1 - s_t)E[R]_{t+1}W_{t-1}H_t$$

$H_t = 25$ and $s_t = 0.5$) when the probability of accessing external credit decreases. Cash holdings are marginally sensitive to changes in the interest rate for external borrowing, X_t . The firm's reaction to changes in interest rate for external borrowing is minimal. However, it responds to changes in probability of getting a loan.

When we fix $E[R]_{t+1} = 1.2$ and $W_{t-1} = 30$, the optimal level of cash decreases as the expected return on investment $E[R]_{t+1}$ increases (see Figure 2). The expected return on investment is the opportunity cost of holding liquid assets. The sensitivity of cash is higher when $s_t = 0.5$, and is lower when $s_t = 0.0$. When expected earnings are low ($E[R]_{t+1}=1.1$), cash holdings decrease when the bounds of cash shock distribution increase. However, when expected return on investment is much higher ($E[R]_{t+1}=1.7$) the optimal cash holdings first increase in response to increase of bounds of cash shock distribution, and then decrease. Thus, when a firm expects high return, it has a non-linear response to uncertainty.

Figure 3 represents the relationship among cash holdings, C_t , bounds of cash shock distribution, H_t and the probability of receiving credit when the firm does not have enough liquid assets to cover negative cash shock, s_t . When $W_{t-1} = 30$, $X_t = 1.3$ or $X_t = 1.6$ and $R_{t+1} = 1.2$ cash holdings decrease in response to an increase in the probability of getting a loan. The relationship between cash holdings and bounds of cash shock distribution can be either positive or negative depending on levels of other variables.

Finally, Figure 4 describes the relationship among share of initial wealth used as cash holdings, initial wealth and bounds of cash holding distribution. Fixing $E[R]_{t+1} = 1.2$, $X_t = 1.3$ and $s_t = 0.0$ or $s_t = 0.5$ we observe a decrease in liquidity ratio when initial wealth increases. Moreover, there is a negative relationship between cash share and bounds of cash distribution.

Our theoretical model predicts positive sign for α_1 and negative signs for α_2 and α_5 . The signs of α_3 and α_4 depend on the levels of the firm's variables.

2.3 Parametrization

In order to test our theoretical model we have to make some parametrization assumptions. We assume that the firm maximizes its profit equal to

$$\Pi(K_t, L_t) = P(Y_t)Y_t - w_t L_t - f_t$$

where $P(Y_t)$ is an inverted demand curve, f_t represents fixed costs, L_t is labor and w_t is wages. The firm produces output, Y given by the production function $F(K_t, L_t)$.

Expected return on investment, $E[R]_{t+1}$ is equal to expected marginal profit of capital, which is contribution of one extra unit of capital to profit.

$$E[R]_{t+1} = E \left[\frac{\partial \Pi}{\partial K} \right] = \frac{E[P]_{t+1}}{\mu} \frac{\partial Y}{\partial K}$$

where $\mu = 1/(1 + 1/\eta)$ and η is price elasticity of demand, $\eta = \frac{\partial Y}{\partial P} \frac{P_{t+1}}{Y_{t+1}}$.

Assuming Cobb–Douglas production function, $Y_{t+1} = A_{t+1} K_{t+1}^{\alpha_k} L_{t+1}^{\alpha_l}$ we rewrite marginal product of capital, $\frac{\partial Y}{\partial K}$ as

$$E[R]_{t+1} = \frac{E[P]_{t+1}}{\mu} \frac{\alpha_k Y_{t+1}}{K} = \frac{\alpha_k}{\mu} \frac{E[S]_{t+1}}{K_{t+1}} = \frac{\alpha_k}{\mu} \left(\frac{S_{t+1}}{K_{t+1}} \right) + \kappa + \omega + \nu \quad (7)$$

where $E[S]$ denotes expected sales, equal to sales in period $t + 1$. Furthermore, we assume rational expectations that allow us to replace expectations with future values plus a firm–specific expectation error term, ν_t , orthogonal to information set available at the time when optimal cash holdings are chosen. Moreover, we allow for different profitabilities of capital among firms and industries, adding an industry specific term, κ , and a firm specific term, ω .

In linearized form we have

$$E[\widehat{R}]_{t+1} = \theta \left(\frac{\widehat{S}_{t+1}}{K_{t+1}} \right) + \kappa + \omega + \nu_t \quad (8)$$

We also assume that firm existed in the period $t - 1$ and survived in case of negative cash flow shock. Its initial wealth, W_{t-1} is equal to $W_{t-1} = C_{t-1} + R_t I_{t-1} + \psi_{t-1} + B_{t-1}$,

where I_{t-1} is investment in the period $t - 1$, C_{t-1} is cash in the previous period, R_t is return on investment in period t , ψ_{t-1} is level of the cash flow shock just before the period t and B_{t-1} is the amount of borrowed funds if the firm went to external market. The linearized initial wealth is equal to

$$\widehat{W}_{t-1} = \zeta_1 \widehat{C}_{t-1} + \zeta_2 \widehat{I}_{t-1} + \zeta_3 \widehat{\psi}_{t-1} + \zeta_4 \widehat{B}_{t-1} \quad (9)$$

Higher debt increases financial constraints and it does not allow the firm to increase the level of liquidity.¹³

Interest rate on borrowing in the case when the firm does not have enough cash to cover negative cash flow shock is parametrized:

$$\widehat{X}_t = \widehat{Interest}_t \quad (10)$$

where X_t is the interest rate for external borrowing.¹⁴

We employ macroeconomic uncertainty and idiosyncratic uncertainty as determinants of bounds of cash flow shock distribution. $H_t = \beta_1^2 \tau_t^2 + \beta_2^2 \epsilon_t^2 + \beta_1 \beta_2 cov(\tau_t, \epsilon_t)$. Keeping the covariance term constant we get linearized version

$$\widehat{H}_t = \beta_1^2 \widehat{\tau}_t^2 + \beta_2^2 \widehat{\epsilon}_t^2 \quad (11)$$

where τ_t^2 denotes macroeconomic uncertainty proxy while ϵ_t^2 is idiosyncratic uncertainty measure.

Finally, probability of getting a loan, s_t is parametrized as

$$\widehat{s}_t = \gamma_1 \widehat{Leading}_t + \gamma_2 E[\widehat{R}]_{t+1} \quad (12)$$

where $Leading_t$ is index of leading indicators that denotes overall economic health, $E[R]_{t+1}$ is expected return on investment. Better economic environment and/or higher expected return on investment increase probability of getting credit.

¹³ See also Baskin (1987), Opler et al. (1999), Ozkan and Ozkan (2004)

¹⁴We assume that loan interest rate is a function of risk-free interest rate, $X_t = \eta * Interest_t$.

Substituting parametrized expressions into Equation 6 yields

$$\begin{aligned}\hat{C} = & \alpha_1\zeta_1\widehat{C}_{t-1} + \alpha_1\zeta_2\widehat{I}_{t-1} + \zeta_3\widehat{\psi}_{t-1} + (\alpha_2 + \alpha_5\gamma_2)\theta\left(\frac{\widehat{S}}{\widehat{K}}\right)_{t+1} + \alpha_3\beta_1^2\widehat{\tau}_t^2 \\ & + \alpha_3\beta_2^2\widehat{\epsilon}_t^2 + \alpha_4\widehat{Interest}_t + \alpha_5\gamma_1\widehat{Leading}_t + \alpha_5\zeta_4\widehat{B}_{t-1} + (\alpha_2 + \alpha_5\gamma_2)(\kappa + \omega + \nu)\end{aligned}$$

After normalization of cash holdings, debt and investment by total assets we get our econometric model specification for firm i at time t :

$$\begin{aligned}\frac{\widehat{C}_{it}}{TA_{it}} = & \phi_1\frac{\widehat{C}_{it-1}}{TA_{it-1}} + \phi_2\frac{\widehat{I}_{it-1}}{TA_{it-1}} + \phi_3\frac{\widehat{S}_{it+1}}{TA_{it+1}} + \phi_4\frac{\widehat{B}_{it-1}}{TA_{it-1}} \\ & + \phi_5\widehat{Leading}_t + \phi_6\widehat{Interest}_t + \phi_7\widehat{\psi}_{t-1} + \phi_8\widehat{\epsilon}_{it}^2 + \phi_9\widehat{\tau}_{t-1}^2 + \kappa'_t + \omega'_t + \nu'_{it}\end{aligned}\quad (13)$$

where $\phi_1 - \phi_9$ are functions of model parameters, ϵ_{it}^2 and τ_{it-1}^2 stand for idiosyncratic and macroeconomic uncertainty respectively.

Since COMPUSTAT gives end-of-period values for firms, we include lagged proxies for macroeconomic variables in the regressions instead of contemporaneous proxies. Thus, we can say that recently-experienced volatility will affect firms' behavior. The first hypothesis of our paper can be stated as:

$$\begin{aligned}H_0 & : \phi_8 = 0 \\ H_1 & : \phi_8 \neq 0\end{aligned}\quad (14)$$

That is, idiosyncratic uncertainty affects the optimal level of cash holdings. The second hypothesis is described as:

$$\begin{aligned}H_0 & : \phi_9 = 0 \\ H_1 & : \phi_9 \neq 0\end{aligned}\quad (15)$$

That implies that managers of a firm find it optimal to change their level of liquid assets in response to uncertainty in macroeconomic environment.

2.4 Macroeconomic uncertainty identification

The macroeconomic uncertainty identification approach resembles the one used by Baum et al. (2002). Firms determine the optimal liquid assets holdings in anticipation of future profitability and cash–holding shocks. The difficulty of evaluating the optimal amount of liquidity increases with the level of macroeconomic uncertainty.

The literature suggests candidates for macroeconomic uncertainty proxies such as moving standard deviation (see Ghosal and Loungani (2000)), standard deviation across 12 forecasting terms of the output growth and inflation rate in the next 12 month (see Driver and Moreton (1991)). However, as in Driver, Temple and Urga (2002) and Byrne and Davis (2002) we use a GARCH model for measuring macroeconomic uncertainty. We argue that this approach suits better in our case because disagreement among forecasters may not a valid uncertainty measure and it may contain measurement errors. Finally, conditional variance is a better candidate for uncertainty comparing to unconditional variance, because it is obtained using the previous period’s information set.

As a macroeconomic uncertainty measure, the conditional variance of the detrended log industrial production is used to capture the uncertainty emerging from the economy.¹⁵

We draw our series for measuring macroeconomic uncertainty from from industrial production (International Financial Statistics series 64 IZZ F). We build a generalized ARCH (GARCH(2,2)) model for the series, where the mean equation is an autoregression.¹⁶ Details of the estimated model are described in Table 1. We have significant ARCH and GARCH coefficients for both time series. The conditional variances derived from these GARCH models are averaged to the quarterly frequency and then

¹⁵We regress $\log(IP_t)$ on trend and constant. The generated residuals from this equation are used as detrended log of industrial production.

¹⁶We try also ARCH(GARCH(2,1)) model to check whether results are sensitive to the ARCH specification model. We obtain quantitatively similar results.

used in the analysis.

2.5 Idiosyncratic uncertainty proxy

There are different measures of firm-specific risk employed in the literature. Sterken, Lensink and Bo (2001) use three measures: stock price volatility, estimated as difference between the highest and the lowest stock price normalized by the lowest price; volatility of sales measured by a seven-year window coefficient of variation of sales; and volatility of number of employees estimated similar to volatility of sales.

A slightly different approach is used in Bo (1999). First, he sets up the forecasting AR(1) equation for the underlying uncertainty variable. Second, the unpredictable part of the fluctuations, the estimated residuals, are obtained. Third, the estimated three-year moving average standard deviation is obtained. As underlying variables the author uses sales and interest rates.

In addition to sales uncertainty, Kalckreuth (2000) also uses cost uncertainty. He runs a regression with operating costs as dependent variable and sales as independent. The three month aggregated orthogonal residuals are further used as uncertainty measures.

In contrast to the mentioned firm uncertainty measures, we employ the standard deviation of close price for the stock of firm during last nine months.¹⁷ This measure is calculated using COMPUSTAT items *data12*, 1st month of quarter close price; *data13*, 2nd month of quarter close price; *data14*, 3rd month of quarter close price; and their first and second lags. We suggest that volatility of stock prices reflect not only sales or costs uncertainty, but also captures other idiosyncratic risks.

¹⁷To check the robustness of our results to the change of window of variation we also try standard deviation of close price for the stock during last 6 months and we receive quantitatively similar results.

3 Empirical Implementation

3.1 Dataset

For empirical investigation of cash holdings determinants we work with the COMPUSTAT Quarterly database of U.S. firms. The initial database includes 173,505 firm-quarter characteristics over 1991-2001. We restrict our analysis to manufacturing companies for which COMPUSTAT provides information. The firms are classified by two-digit Standard Industrial Classification (SIC). The main advantage of the dataset is that it contains detailed balance sheet information. However, one potential shortcoming of the data is the significant over-representation of large companies.

In order to construct firm-specific variables we utilize COMPUSTAT data items Cash and Short-term Investment (*data1* item) and Total Assets (*data6* item), Long-term debt (*data9* item) and Capital Expenditures (*data90* item), Sales (*data2* item) for Leverage ($Cash/TA$), Investment-to-Asset ratio (I/TA) and Sales-to-Asset ratio (S/TA). Moreover, cash-flow shock is calculated as percentage change of Cash and Short-term Investment variable.¹⁸

We also apply a few sample selection criteria to the original sample. The following sets of the firms are set as missing in our sample: (a) negative values for cash-to-assets, leverage, sales-to-assets and investment-to-assets ratios; (b) the values of ratio variables lower than 1st percentile or higher than 99th percentile. We decided to use the screened data to reduce the potential impact of outliers upon the parameter estimates. After the screening and including only manufacturing sector firms we obtain on average 700 firms' quarterly characteristics.¹⁹

Table 2 presents descriptive statistics $Cash/TA$, B/TA , S/TA , I/TA and ψ variables for the pooled time-series cross-sectional data. There are possible a 32,252

¹⁸ $Cash_shock = (Cash_t - Cash_{t-1})/Cash_{t-1}$.

¹⁹We also use winsorized measures of balance sheet measures and receive similar quantitative results.

firm–quarter observations for each variable. However, because of missing observations all panel data variables have less than 32,252 firm–quarter observations. The smallest number of observation is for the ψ variable with 27,375 observations. The median and mean for C/TA are 3% and 7% respectively. Thus, cash holdings are an important component of total assets.

We subdivide the data of manufacturing–sector firms (two–digit SIC 20–39) into producers of durable goods and producers of non–durable goods on the basis of SIC firms’ codes. A firm is considered DURABLE if its primary SIC is 24, 25, 32–39.²⁰ SIC classifications for NON–DURABLE industries are 20–23 or 26–31.²¹

As a macroeconomic environment variable, we also use the detrended index of leading indicators ($Leading_t$) and interest rate, ($Interest$). The former is computed from DRI–McGraw Hill Basic Economics series DLEAD. In order to detrend we regress the index on trend and constant and generated residuals consider as a detrended index. The latter is three–month Treasury Bill rate obtained from the same database ($FYGM3$ item).

3.2 Empirical results

This subsection contains the findings of our investigation of the determinants of cash holdings. Estimates of the optimal corporate structures usually suffer from endogeneity problems, and the use of instrumental variables may be considered as a possible solution. We estimate our econometric models using system dynamic panel data estimator. It combines differenced equations with level equations to make a system GMM (see Blundell and Bond (1998)). Lagged levels are used as instruments for differenced equations and lagged differences are used as instruments for level equations.

²⁰These industries include lumber and wood products, furniture, stone, clay, and glass products, primary and fabricated metal products, industrial machinery, electronic equipment, transportation equipment, instruments, and miscellaneous manufacturing industries.

²¹These industries include food, tobacco, textiles, apparel, paper products, printing and publishing, chemicals, petroleum and coal products, rubber and plastics, and leather products makers.

The models are estimated using an orthogonal transformation for cleaning the firm specific effect.²²

The reliability of the our econometric methodology depends on validity of instruments. We check it with Sargan’s test of overidentifying restrictions, which is asymptotically distributed as χ^2 . The consistency of estimates also depends on the serial correlation in the error terms. We present tests for first-order and second-order serial correlation. Moreover, two-step results are estimated using (Windmeijer, 2000) finite sample correction.

The results of estimating Equation (14) are given in Tables 3–4 for all manufacturing firms, durable-goods makers and non-durable goods makers respectively. Column (1) of Table 3 represents the Arellano–Bond one-step system GMM estimator with weighted conditional variance of industrial production and weighted conditional variance of money growth as proxies for macroeconomic uncertainty. Column (2) contains the results from two-step system GMM estimator. In columns (3) and (4) we also include detrended index of leading indicators ($Leading_{t-1}$) and interest rate ($Interest_{t-1}$) in order to control for the macroeconomic environment.

Our main findings include a positive and significant relationship between cash-to-assets ratios of US non-financial firms and uncertainty measures. The coefficients for the macroeconomic uncertainty variables varies from 0.0203 to 0.0269 and are statistically different from zero. Idiosyncratic uncertainty also matters with coefficients varying between 0.0155–0.0177.

The results also suggest significant positive persistence in the liquidity ratio (0.8998 – 0.9021). The coefficients for cash-flow shock is negative that means that the firm

²²The orthogonal transformation uses

$$x^*_{it} = \left(x_{it} - \frac{x_{i(t+1)} + \dots + x_{iT}}{T-t} \right) \left(\frac{T-t}{T-t+1} \right)^{1/2}$$

where the transformed variable does not depend on its lagged values.

is likely to increase cash holdings if it faced a negative cash shock in the previous period. The effect of interest rate is positive suggesting that firms increase liquidity if they face increase in interest rate for external borrowing. However, this effect is small as has been also predicted by our theoretical model. The coefficient is equal to 0.0005.

Negative and significant effect of the next period's expected sales-to-assets ratio also responds to our expectations. It is used as a proxy for expected return on investment. When expected opportunity cost of holding cash increases, firms are likely to decrease liquidity ratio. Lagged value of leverage ratio has a negative effect on liquidity ratio. Firms facing higher debt burden are not able to maintain big cash stock.

We receive an interesting contrast in results for durable good makers and non-durable goods makers reported in Table 4. Durable goods makers exhibit negative significant effects for macroeconomic uncertainty. However, macroeconomic uncertainty does not really affect behavior of non-durable goods makers. Since durable goods makers' products generally involve greater time lags in production and larger inventories of work-in-progress, they are also more sensitive to macroeconomic uncertainty than are nondurable-goods producers. Idiosyncratic uncertainty similarly affects both groups of firms.

In summary, we find strong support for our hypotheses (Equations 14 and 15). Firms increase liquidity ratio in uncertain times. The results are qualitatively different for durable and non-durable good makers. When macroeconomic environment is more less predictable, companies become more cautious and increase liquidity ratio. Note that these results confirm the results regarding the impact of uncertainty on investment reported in Bloom, Bond and Reenen (2001).

4 Conclusions

This paper investigates the link between the level of liquidity of manufacturing firms and uncertainty measures using Quarterly COMPUSTAT data. Based on the theoretical predictions developed using a simple static wealth maximization problem, we anticipate that firms will increase the level of cash holdings when uncertainty increases. This result confirms the existence of a *precautionary motive* for maintaining cash level. In order to test empirically our model we employ dynamic panel data methodology. The results suggest negative and significant effects of uncertainty on cash holdings for US non-financial firms during 1991–2001.

There are significant differences in results for durable good makers and non-durable goods manufacturers. The former group exhibits larger sensitivity to macroeconomic uncertainty from monetary policy makers side, while the latter firms react to changes in industrial production volatility. Our results are shown to be robust to inclusion of such macroeconomic variables as the index of leading indicators and the interest rate.

This outcome can be used for monetary policy decisions. Policy shocks that ignore effects of uncertainty on liquidity maybe based on biased measure of demand for liquid assets. Any balance sheet shocks affect the amplitude of investment cycle in a simple neoclassical world (Bernanke and Gertler, 1989). Furthermore, monetary policy can affect the demand for cash through credit channel. In the time of tight monetary policy when interest rate is high firms find harder to get access to external financing (see Yalcin, Bougheas and Mizen (2003)).

References

- Almeida, H., Campello, M. and Weisbach, M. (2004), ‘The cash flow sensitivity of cash’, *Journal of Finance* **59**(4), 1777–1804.
- Arellano, M. and Bond, S. (1991), ‘Some tests of specification for panel data: Monte carlo evidence and an application to employment equations’, *Review of Economic Studies* **58**(2), 277–97.
- Baskin, J. B. (1987), ‘Corporate liquidity in games of monopoly power’, *The Review of Economics and Statistics* **69**(2), 312–19.
- Baum, C. F., Caglayan, M., Ozkan, N. and Talavera, O. (2002), The impact of macroeconomic uncertainty on cash holdings for non-financial firms, Working Papers 552, Boston College Department of Economics.
- Bernanke, B. and Gertler, M. (1989), ‘Agency costs, net worth, and business fluctuations’, *American Economic Review* **79**(1), 14–31.
- Bloom, N., Bond, S. and Reenen, J. V. (2001), The dynamics of investment under uncertainty, Working Papers WP01/5, Institute for Fiscal Studies.
- Blundell, R. and Bond, S. (1998), ‘Initial conditions and moment restrictions in dynamic panel data models’, *Journal of Econometrics* **87**(1), 115–143.
- Bo, H. (1999), The Q theory of investment: Does uncertainty matter?, Working Papers 07, University of Groningen.
- Bruinshoofd, W. (2003), Corporate investment and financing constraints: Connections with cash management, WO Research Memoranda (discontinued) 734, Netherlands Central Bank, Research Department.

- Byrne, J. P. and Davis, E. P. (2002), Investment and uncertainty in the G7, Discussion papers, National Institute of Economic Research, London.
- Charlton, W. T., Lancaster, C. and Stevens, J. L. (2002), 'Industry and liquidity effects in corporate investment and cash relationships', *The Journal of Applied Business Research* **18**(1), 131–142.
- Cummins, J. G., Hasset, K. A. and Oliner, S. D. (1995), Investment behavior, observable expectations, and internal funds, Working Papers 97-30, C.V. Starr Center for Applied Economics, New York University.
- Driver, C. and Moreton, D. (1991), 'The influence of uncertainty on aggregate spending', *Economic Journal* **101**, 1452–1459.
- Driver, C., Temple, P. and Urga, G. (2002), Profitability, capacity, and uncertainty: A robust model of UK manufacturing investment, Royal Economic Society Annual Conference 2002 66, Royal Economic Society.
- Fazzari, S., Hubbard, R. G. and Petersen, B. C. (1988), 'Financing constraints and corporate investment', *Brookings Papers on Economic Activity* **78**(2), 141–195.
- Ghosal, V. and Loungani, P. (2000), 'The differential impact of uncertainty on investment in small and large business', *The Review of Economics and Statistics* **82**, 338–349.
- Harford, J. (1999), 'Corporate cash reserves and acquisitions', *Journal of Finance* **54**, 1967–1997.
- Kalckreuth, U. (2000), Exploring the role of uncertainty for corporate investment decisions in Germany, Discussion Papers 5/00, Deutsche Bundesbank - Economic Research Centre.

- Keynes, J. M. (1936), *The general theory of employment, interest and money*, London, Harcourt Brace.
- Kim, Chang-Soo, D. C. M. and Sherman, A. E. (1998), ‘The determinants of corporate liquidity: Theory and evidence’, *Journal of Financial and Quantitative Analysis* **33**, 335–359.
- Mills, K., Morling, S. and Tease, W. (1994), The influence of financial factors on corporate investment, RBA Research Discussion Papers rdp9402, Reserve Bank of Australia.
- Modigliani, F. and Miller, M. (1958), ‘The cost of capital, corporate finance, and the theory of investment’, *American Economic Review* **48**(3), 261–297.
- Myers, S. C. and Majluf, N. S. (1984), ‘Corporate financing and investment decisions when firms have information that investors do not have’, *Journal of Financial Economics* **13**, 187–221.
- Opler, T., Pinkowitz, L., Stulz, R. and Williamson, R. (1999), ‘The determinants and implications of cash holdings’, *Journal of Financial Economics* **52**, 3–46.
- Ozkan, A. and Ozkan, N. (2004), ‘Corporate cash holdings: An empirical investigation of UK companies’, *Journal of Banking and Finance* **in press**.
- Schnure, C. (1998), Who holds cash? and why?, Finance and Economics Discussion Series No. 1998-13, Board of Governors of the Federal Reserve System.
- Sterken, E., Lensink, R. and Bo, H. (2001), Investment, cash flow, and uncertainty: Evidence for the Netherlands, Working Papers 14, University of Groningen.
- Windmeijer, F. (2000), A finite sample correction for the variance of linear two-step GMM estimators, Working Papers WP00/19, Institute for Fiscal Studies.

Yalcin, C., Bougheas, S. and Mizen, P. (2003), Corporate credit and monetary policy: The impact of firm-specific characteristics on financial structure, Discussion Papers 2003/1, European University Institute.

Appendix A: Construction of macroeconomic and firm specific measures

The following variables are used in the quarterly empirical study.

From the COMPUSTAT database:

DATA1: Cash and Short-Term Investments

DATA2: Sales

DATA6: Total Assets

DATA9: Long-Term Debt

DATA12: 1st month of quarter close price

DATA13: 2nd month of quarter close price

DATA14: 3rd month of quarter close price

DATA90: Capital Expenditures

From International Financial Statistics:

64IZF: Industrial Production monthly

From the DRI-McGraw Hill Basic Economics database:

DLEAD: index of leading indicators

FYGM3: 3-month U.S. treasury bills interest rate

Table 1: GARCH (2,1) and GARCH (2,2) proxies for macroeconomic uncertainty.

	GARCH(2,1)	GARCH(2,2)
$\log(IP)_{t-1}$	0.9812*** [0.0099]	0.9810*** [0.0102]
Constant	0.0006 [0.0006]	0.0006 [0.0001]
AR(1)	0.8076*** [0.0680]	0.8057*** [0.0701]
MA(1)	-0.5904*** [0.0968]	-0.5874*** [0.0977]
ARCH(1)	0.2915*** [0.0542]	0.2868*** [0.0549]
ARCH(2)	-0.2039*** [0.0497]	-0.2192*** [0.0361]
GARCH(1)	0.8888*** [0.0305]	0.9717*** [0.1395]
GARCH(2)		-0.0582 [0.1166]
Constant	0.0000** [0.0000]	-0.0000 [0.0000]
Observations	535	535

Note: Models fit to detrended log(Industrial production) and to money growth. * significant at 10%; ** significant at 5%; *** significant at 1%.

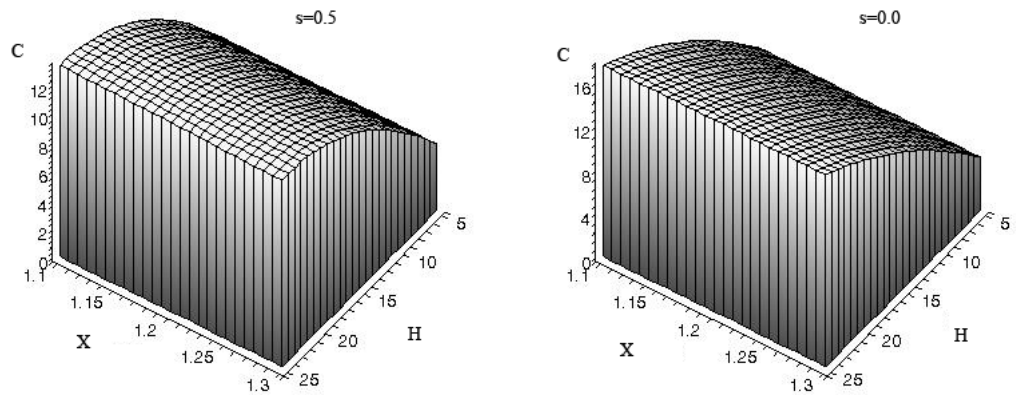

Figure 1: Plot of C_t against X_t and H_t ($s_t = 0$ and $s_t = 0.5$, $W_{t-1} = 30$, $E[R]_{t+1} = 1.2$)

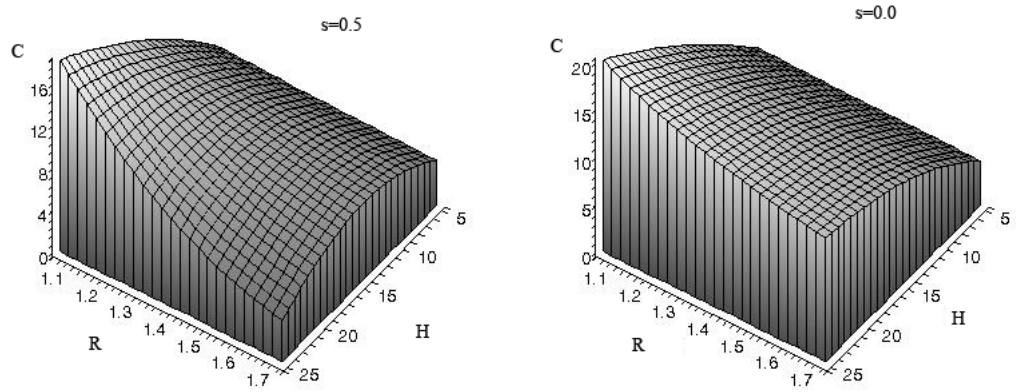

Figure 2: Plot of C_t against $E[R]_{t+1}$ and H_t ($s_t = 0$ and $s_t = 0.5$, $W_{t-1} = 30$, $X_t = 1.3$)

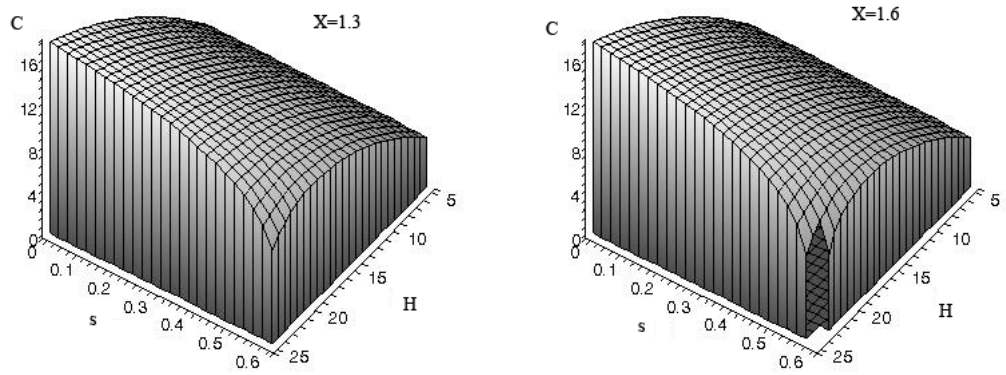

Figure 3: Plot of C_t against s_t and H_t ($X_t = 1.3$ and $X_t = 1.6, W_{t-1} = 30, E[R]_{t+1} = 1.2$)

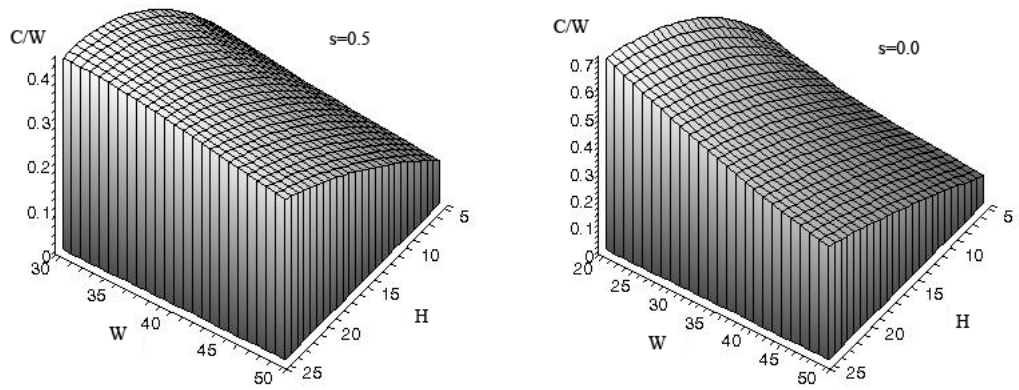

Figure 4: Plot of C_t/W_{t-1} against W_{t-1} and H_t ($s_t = 0$ and $s_t = 0.5, E[R]_{t+1} = 1.2, X_t = 1.3$)

Table 2: Descriptive Statistics

All firms	μ	σ^2	p_{25}	p_{50}	p_{75}	N
$Cash/TA_t$	0.0743	0.0097	0.0118	0.0327	0.0954	28263
S/TA_t	0.3030	0.0189	0.2121	0.2826	0.3687	28502
I/TA_t	0.0367	0.0012	0.0133	0.0269	0.0489	27787
B/TA_t	0.2129	0.0243	0.0902	0.1910	0.3073	28872
ψ_t	0.2951	2.0935	-0.2353	0.0080	0.3015	27375
Durable						
$Cash/TA_t$	0.0793	0.0103	0.0137	0.0372	0.1030	16489
S/TA_t	0.3069	0.0182	0.2174	0.2869	0.3695	16626
I/TA_t	0.0356	0.0012	0.0128	0.0258	0.0467	16150
B/TA_t	0.2041	0.0234	0.0831	0.1799	0.2962	16747
ψ_t	0.2970	2.0136	-0.2323	0.0083	0.2962	15941
Non-Durable						
$Cash/TA_t$	0.0672	0.0089	0.0100	0.0271	0.0864	11774
S/TA_t	0.2975	0.0199	0.2039	0.2766	0.3673	11876
I/TA_t	0.0382	0.0012	0.0141	0.0285	0.0518	11637
B/TA_t	0.2251	0.0253	0.1024	0.2060	0.3202	12125
ψ_t	0.2923	2.2049	-0.2392	0.0074	0.3091	11434

Note: p_{25} , p_{50} and p_{75} represent the quartiles of the distribution, N is sample size, while σ^2 and μ represent its variance and mean respectively.

Table 3: Determinants of Cash Holdings, all manufacturing firms

Variable	1-Step (1)	2-step (2)	1-step (3)	2-step (4)
C/TA_{t-1}	0.8998*** [0.0068]	0.9018*** [0.0069]	0.8999*** [0.0068]	0.9021*** [0.0070]
B/TA_{t-1}	-0.0110*** [0.0021]	-0.0108*** [0.0021]	-0.0105*** [0.0021]	-0.0104*** [0.0021]
I/TA_{t-1}	-0.0261*** [0.0101]	-0.0243** [0.0098]	-0.0271*** [0.0101]	-0.0252*** [.00978]
S/TA_{t+1}	-0.0159*** [0.0036]	-0.0153*** [0.0035]	-0.0165*** [0.0037]	-0.0156*** [0.0036]
ψ_{t-1}	-0.0020*** [0.0002]	-0.0020*** [0.0002]	-0.0020*** [0.0002]	-0.0020*** [0.0002]
$Idiosyncratic_t$	0.0166** [0.0068]	0.0155** [0.0065]	0.0177*** [0.0068]	0.0165*** [0.0065]
CV_IP_{t-1}	0.0216*** [0.0079]	0.0203*** [0.0073]	0.0269*** [0.0082]	0.0247*** [0.0077]
$Leading_{t-1}$			-0.0002*** [0.0000]	-0.0002*** [0.0000]
$Interest_t$			0.0005** [0.0002]	0.0004** [0.0002]
Sargan	0.000	0.202	0.000	0.208
LM(1)	-13.36***	-12.86***	-13.37***	-12.86***
LM(2)	-1.161	-1.117	-1.162	-1.122
N. Obs	23932	23932	23932	23932

Note: Every equation includes constant and industry dummy variables. Asymptotic robust standard errors are reported in the brackets. Estimation by SYS-GMM using DPD package for OX. “Sargan” is a Sargan–Hansen test of overidentifying restrictions (p-value reported). “LM (k)” is the test for k -th order autocorrelation. GMM instruments are B/TA , $CASH/TA$, I/TA , $Idiosyncratic$ and S/TA from $t - 2$ to $t - 4$ and GMM level instruments are $\Delta B/TA$, $\Delta CASH/TA$, $\Delta I/TA$, $\Delta Idiosyncratic$ and $\Delta S/TA$ from $t - 1$ to $t - 4$. * significant at 10%; ** significant at 5%; *** significant at 1%.

Table 4: Determinants of Cash Holdings, Durable/Non-durable goods makers

Variable	Durable		Non-Durable	
	1-Step (1)	2-step (2)	1-step (3)	2-step (4)
C/TA_{t-1}	0.9042*** [0.0086]	0.9064*** [0.0086]	0.8935*** [0.0112]	0.8962*** [0.0112]
B/TA_{t-1}	-0.0129*** [0.0028]	-0.0127*** [0.0028]	0.00732** [0.0033]	0.00726** [0.0033]
I/TA_{t-1}	-0.0349*** [0.0119]	-0.0356*** [0.0116]	-0.0178 [0.0176]	-0.0169 [0.0162]
S/TA_{t+1}	-0.0147*** [0.0050]	-0.0135*** [0.0049]	-0.0193*** [0.0054]	-0.0177*** [0.0055]
ψ_{t-1}	-0.0021*** [0.0003]	-0.0020*** [0.0003]	-0.0020*** [0.0003]	-0.0019*** [0.0003]
$Idiosyncratic_t$	0.0181* [0.010]	0.0178* [0.010]	0.0175** [0.0088]	0.0176** [0.0089]
CV_IP_{t-1}	0.0296*** [0.0102]	0.0281*** [0.0099]	0.0236* [0.0136]	0.0184 [0.0119]
$Leading_{t-1}$	-0.0003*** [0.0001]	-0.0003*** [0.0001]	-0.0001 [0.0001]	-0.0001 [0.0001]
$Interest_t$	0.0005 [0.0003]	0.0004 [0.0003]	0.0005 [0.0003]	0.0005 [0.0003]
Sargan	0.000	0.997	0.000	1.000
LM(1)	-10.94***	-10.45***	-7.836***	-7.573***
LM(2)	-0.4404	-0.4347	-1.276	-1.230
N. Obs	14045	14045	9887	9887

Note: Every equation includes constant and industry dummy variables. Asymptotic robust standard errors are reported in the brackets. Estimation by SYS-GMM using DPD package for OX. “Sargan” is a Sargan–Hansen test of overidentifying restrictions (p-value reported). “LM (k)” is the test for k -th order autocorrelation. GMM instruments are B/TA , $CASH/TA$, I/TA , $Idiosyncratic$ and S/TA from $t - 2$ to $t - 3$. GMM level instruments are $\Delta B/TA$, $\Delta CASH/TA$, $\Delta I/TA$, $\Delta Idiosyncratic$ and $\Delta S/TA$ from $t - 1$ to $t - 3$. * significant at 10%; ** significant at 5%; *** significant at 1%.