

For Office Use Only

PANEL SCF



The University of Michigan
Survey Research Center
Institute for Social Research
Ann Arbor, MI 48106

INTERVIEWER LABEL

1. IWER ID No.: _____

2. Your IW No.:

3. Date of IW: _____

4. Length of IW: _____ (minutes)

5. Length of Edit: _____ (minutes)

6. Mode of IW: 1. 2.

Face-to-Face Telephone

THIS STATEMENT MUST BE READ TO ALL RESPONDENTS

This interview is completely voluntary and confidential. If we should come to any question you do not want to answer, let me know and we'll go on to the next question. Your answers will be kept completely confidential.

REVIEWED BY:

<input type="checkbox"/> SUPERVISOR _____	<input type="checkbox"/> EDITOR _____
DATE	DATE



THIS IS A BLANK PAGE

SECTION A: ATTITUDES AND FINANCIAL INSTITUTIONS

A0. EXACT TIME NOW: _____

A1. I'd like to start this interview by asking you about your expectations for the future. Over the next five years, do you expect the U.S. economy as a whole to perform better, worse, or about the same as it has over the past five years?

1. BETTER

2. WORSE

3. ABOUT THE SAME

A2. Five years from now, do you think interest rates will be higher, lower, or about the same as today?

1. HIGHER

2. LOWER

3. ABOUT THE SAME

A3. Over the next five years, do you expect your total (family) income to go up more than prices, less than prices, or about the same as prices?

1. UP MORE

2. UP LESS

3. ABOUT THE SAME

A4. Over the past five years, did your total (family) income go up more than prices, less than prices, or about the same as prices?

1. UP MORE

2. UP LESS

3. ABOUT THE SAME

A5. The next few questions are about the financial institutions that you do business with.

How many financial institutions do you (and your family living here) have accounts with or regularly do personal financial business with? Include banks, savings and loans, credit unions, loan companies, and brokerages. Do not include institutions where you have only a credit card account.

(IWER: ACCOUNTS USED ONLY FOR BUSINESS SHOULD NOT BE INCLUDED)

01. ONE	_____ NUMBER	96. NONE
↓	GO TO A5b	TURN TO P. 7, SECTION B
<p>A5a. What is the name of this financial institution?</p> <p>(IWER: WRITE THE NAME OF THIS INSTITUTION ON LINE 1 OF CARD A. IF INTERVIEW IS IN PERSON, HAND R CARD A. READ:) This will be referred to as Institution #1 throughout the interview.</p>		

GO TO A5k

A5b. IWER: ASK A5c - A5h AND WRITE NAMES OF FINANCIAL INSTITUTIONS ON CARD A.
NOTE: ORDER IN WHICH INSTITUTIONS ARE LISTED IS NOT IMPORTANT.

- A5c. What is the name of your (family's) main financial institution?
- A5d. What is the name of your (family's) next financial institution?
- A5e. (And the third?)
- A5f. (And the fourth?)
- A5g. (And the fifth?)
- A5h. (And the sixth?)

A5j. **(IF IW IS IN PERSON, HAND R CARD A, READ:)** The institutions listed on this card will be referred to as Institution #1, #2, (3/4/5/6) throughout the interview.

A5k. Can you (or your family living here) deposit or withdraw money from (this institution/any of these institutions) using an automated teller machine or ATM?

1. YES	5. NO
↓	↓

IWER: RECORD TOTAL NUMBER OF INSTITUTIONS (FROM A5) IN BOX A5m AT TOP OF NEXT PAGE.

A5m. # INST.

A6. (About Institution #[1/2/3/4/5/6]), what kind of institution is this? (Is it a commercial bank, a savings and loan or savings bank, a credit union, a finance or loan company, a brokerage, or what?)

A7. How (do you/does your family) typically do business with this institution (--by ATM, in person, by mail, by phone, or some other way)?

A8. Roughly, how many miles is the office or ATM of this institution from the home or workplace of the person who uses it most often? (ACCEPT RANGE.)
(IF R ASKS: WE WANT THE CLOSER OF THE DISTANCE FROM HOME OR WORKPLACE.)

A9. INTERVIEWER CHECKPOINT
(SEE A5m)

INSTITUTION #1	INSTITUTION #2	INSTITUTION #3
11. COMM. BANK	11. COMM. BANK	11. COMM. BANK
12. S&L/SVINGS BNK	12. S&L/SVINGS BNK	12. S&L/SVINGS BNK
13. CREDIT UNION	13. CREDIT UNION	13. CREDIT UNION
14. FIN./LOAN CO.	14. FIN./LOAN CO.	14. FIN./LOAN CO.
16. BROKERAGE	16. BROKERAGE	16. BROKERAGE
97. OTHER: _____ _____ _____	97. OTHER: _____ _____ _____	97. OTHER: _____ _____ _____
98. DON'T KNOW	98. DON'T KNOW	98. DON'T KNOW
1. BY ATM	1. BY ATM	1. BY ATM
2. IN PERSON	2. IN PERSON	2. IN PERSON
3. BY MAIL	3. BY MAIL	3. BY MAIL
4. BY PHONE	4. BY PHONE	4. BY PHONE
6. DON'T DO REG. BUSINESS	6. DON'T DO REG. BUSINESS	6. DON'T DO REG. BUSINESS
7. OTHER	7. OTHER	7. OTHER
_____ MILES	_____ MILES	_____ MILES
96. LESS THAN A MILE	96. LESS THAN A MILE	96. LESS THAN A MILE
51. OVER 50 MILES	51. OVER 50 MILES	51. OVER 50 MILES
97. LOCAL PHONE OR POST BOX	97. LOCAL PHONE OR POST BOX	97. LOCAL PHONE OR POST BOX
98. DON'T KNOW	98. DON'T KNOW	98. DON'T KNOW
<input type="checkbox"/> 1. ONLY 1 INST. TURN TO P. 7, SECTION B	<input type="checkbox"/> 1. ONLY 2 INST. TURN TO P. 7, SECTION B	<input type="checkbox"/> 1. ONLY 3 INST. TURN TO P. 7, SECTION B
<input type="checkbox"/> 2. ALL OTHERS GO BACK TO A6, INST. # 2	<input type="checkbox"/> 2. ALL OTHERS GO BACK TO A6, INST. # 3	<input type="checkbox"/> 2. ALL OTHERS GO BACK TO A6, INST. # 4

INSTITUTION #4	INSTITUTION #5	INSTITUTION #6
11. COMM. BANK	11. COMM. BANK	11. COMM. BANK
12. S&L/SVINGS BNK	12. S&L/SVINGS BNK	12. S&L/SVINGS BNK
13. CREDIT UNION	13. CREDIT UNION	13. CREDIT UNION
14. FIN./LOAN CO.	14. FIN./LOAN CO.	14. FIN./LOAN CO.
16. BROKERAGE	16. BROKERAGE	16. BROKERAGE
97. OTHER: _____ _____ _____	97. OTHER: _____ _____ _____	97. OTHER: _____ _____ _____
98. DON'T KNOW	98. DON'T KNOW	98. DON'T KNOW
1. ATM	1. ATM	1. ATM
2. IN PERSON	2. IN PERSON	2. IN PERSON
3. BY MAIL	3. BY MAIL	3. BY MAIL
4. BY PHONE	4. BY PHONE	4. BY PHONE
6. DON'T DO REG. BUSINESS	6. DON'T DO REG. BUSINESS	6. DON'T DO REG. BUSINESS
7. OTHER	7. OTHER	7. OTHER
_____ MILES	_____ MILES	_____ MILES
96. LESS THAN A MILE	96. LESS THAN A MILE	96. LESS THAN A MILE
51. OVER 50 MILES	51. OVER 50 MILES	51. OVER 50 MILES
97. LOCAL PHONE OR POST BOX	97. LOCAL PHONE OR POST BOX	97. LOCAL PHONE OR POST BOX
98. DON'T KNOW	98. DON'T KNOW	98. DON'T KNOW
<input type="checkbox"/> 1. ONLY 4 INST. NEXT PAGE, SECTION B <input type="checkbox"/> 2. ALL OTHERS GO BACK TO A6, INST. #5	<input type="checkbox"/> 1. ONLY 5 INST. NEXT PAGE, SECTION B <input type="checkbox"/> 2. ALL OTHERS GO BACK TO A6, INST. #6	NEXT PAGE, SECTION B

THIS IS A BLANK PAGE

SECTION B: ATTITUDES TOWARD CREDIT/CREDIT CARDS

B1. Now I would like to ask you some questions about how you feel about credit. In general, do you think it is a good idea or a bad idea for people to buy things on the installment plan?

- 1. GOOD IDEA
- 3. GOOD IN SOME WAYS,
BAD IN OTHERS
- 5. BAD IDEA
- 8. DON'T KNOW

B2. People have many different reasons for borrowing money which they pay back over a period of time. For each of the reasons I read, please tell me whether you feel it is all right for someone like yourself to borrow money...

- B2a. first, to cover the expenses of a vacation trip?
- B2b. next, to cover living expenses when income is cut?
- B2c. (next,) to finance the purchase of a fur coat or jewelry?
- B2d. (next,) to finance the purchase of a car?
- B2e. finally, to finance educational expenses?

YES (1)	NO (5)	DK (8)

B3. In the past five years, has a particular lender or creditor turned down any request you (or your [husband/wife]) made for credit, or not given you as much credit as you applied for? (Turned down, or not as much credit?)

- 1. YES, TURNED DOWN
- 3. YES, NOT AS MUCH CREDIT
- 5. NO

GO TO B4

B3a. Were you later able to obtain the full amount you (or your husband/wife) requested by reapplying to the same institution or by applying elsewhere?

- 1. YES
- 5. NO

B4. Was there any time in the past five years that you (or your [husband/wife]) thought of applying for credit at a particular place, but changed your mind because you thought you might be turned down?

- 1. YES
- 5. NO

B5. Now I have some questions about credit cards. Do you (or anyone in your family living here) have any credit cards?

1. YES

5. NO -->TURN TO P. 10, SECTION D



TYPE----->
EXAMPLES--->

COLUMN A		COLUMN B	
BANK-TYPE Visa, Mastercard, Discover, Optima		STORE Sears, K-Mart and other Dept. stores	
96. NONE ---->		96. NONE ---->	
_____ #ACCTS		_____ #ACCTS	
97. SOME, DK HOW MANY		97. SOME, DK HOW MANY	
B7. During the last month, roughly how much were the <u>new</u> charges made to (this/all these) (TYPE) account(s)? (ACCEPT RANGE)		\$ _____	
9996. NONE		9996. NONE	
B8. After the last payment(s) (was/were) made on (this/these) account(s), roughly what was the balance still owed on (this/all these) (TYPE) account(s)?		\$ _____	
9996. NONE		9996. NONE	
B9. What is the maximum amount you could borrow on (this/all of these) bank-type account(s); that is, what is your total credit limit?		\$ _____	
B10. (Please look at Card A.) (Is this/are these) with any of the institution(s) (you told me about at the beginning of the interview/on Card A), or from someplace else? (CHECK ALL THAT APPLY.) [IF CARD A: Which institution(s)?] [IF "SOMEPLACE ELSE": What type(s) of institution(s)?]		GO BACK TO B6, COL. C	
01. #1	04. #4		
02. #2	05. #5		
03. #3	06. #6		
11. COMM BANK			
50. SEARS			
51. AM. EXP.			
97. OTHER: _____			

GO BACK TO B6, COL. B

COLUMN C	COLUMN D	COLUMN E
GASOLINE Gulf, Texaco	GENERAL PURPOSE American Express, Diners Club, Carte Blanche	OTHER Airline, Car Rental or other
<input type="checkbox"/> 96. NONE ----->	<input type="checkbox"/> 96. NONE ----->	<input type="checkbox"/> 96. NONE -->B11 GO TO
_____ #ACCTS	_____ #ACCTS	_____ #ACCTS
<input type="checkbox"/> 97. SOME, DK HOW MANY	<input type="checkbox"/> 97. SOME, DK HOW MANY	<input type="checkbox"/> 97. SOME, DK HOW MANY
\$ _____	\$ _____	\$ _____
<input type="checkbox"/> 9996. NONE	<input type="checkbox"/> 9996. NONE	<input type="checkbox"/> 9996. NONE
\$ _____	\$ _____	\$ _____
<input type="checkbox"/> 9996. NONE	<input type="checkbox"/> 9996. NONE	<input type="checkbox"/> 9996. NONE

GO BACK TO
B6, COL. D

GO BACK TO
B6, COL. E

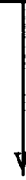

B11. INTERVIEWER CHECKPOINT

SEE B6, COLUMNS A AND B

1. R HAS EITHER BANK CREDIT CARD OR STORE CREDIT CARD

2. ALL OTHERS-->NEXT PAGE, SECTION D



B12. Thinking only about bank cards or store cards, do you almost always, sometimes, or hardly ever pay off the total balance owed on the account each month?

1. ALMOST ALWAYS

3. SOMETIMES

5. HARDLY EVER

SECTION D: HOUSING

D1. Now I have some questions about your housing. First, do you live on a farm or ranch, in a mobile home, in an apartment, a house, or what?

<input type="checkbox"/>	1. R LIVES ON A RANCH OR FARM	
<input type="checkbox"/>	2. R LIVES IN A MOBILE HOME--> TURN TO P. 13, D11	
<input type="checkbox"/>	3. APARTMENT	-->TURN TO P. 15, D16
<input type="checkbox"/>	4. HOUSE	
<input type="checkbox"/>	7. ALL OTHERS	

D2. Now I have some questions about this property. About how many acres is this (farm/ranch)?

_____ ACRES

D3. Do you (or anyone in your family living here) operate a farming or ranching business on this property?

<input type="checkbox"/> 1. YES	<input type="checkbox"/> 5. NO		
↓			
<p>D3a. Do you (or anyone in your family living here) rent out any part of this property to others?</p> <table border="1"> <tr> <td><input type="checkbox"/> 1. YES</td> <td><input type="checkbox"/> 5. NO --> TURN TO P. 15, D16</td> </tr> </table> <p>D3b. How much rent do you collect each month?</p> <p style="text-align: center;">\$ _____ PER _____</p>		<input type="checkbox"/> 1. YES	<input type="checkbox"/> 5. NO --> TURN TO P. 15, D16
<input type="checkbox"/> 1. YES	<input type="checkbox"/> 5. NO --> TURN TO P. 15, D16		
↓			
TURN TO P. 15, D16			

D4. What part of this property is used for the farming or ranching business?

_____ PERCENT OR _____ ACRES 996. VERY LITTLE 995. ALMOST ALL

D5. What is the legal ownership status of this (farm/ranch). Do you (or your family living here) own this (farm/ranch), do you own part of it, do you rent it, is it all owned by a business, or what?

1. OWNS ALL

2. OWNS PART

3. RENTS

4. OWNED BY A BUSINESS

7. OTHER: _____

TURN TO
NEXT PAGE,
P. 15, D17
D6

D5a. Does the (farming/ranching) business pay any rent for the use of the property?

1. YES 5. NO -->GO TO D5c

D5b. How much rent do you (or your family living here) collect each month?

\$ _____ PER _____

D5c. Could you tell me the present value of this house and the immediately surrounding land? I mean, about what would it bring if it were sold today?

\$ _____

D5d. I will ask you more about the business operation later. The rest of the questions in this section will refer to the entire property. Could you tell me the present value of this entire property -- that is, what would it bring if it were sold today?

\$ _____

TURN TO P. 16, D20

IF R OWNS ANY PART OF THE PROPERTY, CHECK BOX 2, "OWNS PART", AND FOLLOW SKIP TO D6. OTHERWISE, GO TO D5f.

D5e. Do you (or your family living here) pay the business any rent for this house?

1. YES 5. NO

TURN TO P. 15, D17

D5f. In what month and year did you move into this (farm/ranch)?

MONTH/YEAR

TURN TO P.27, D68

R OWNS PART OF FARM/RANCH

D6. Does the (farming/ranching) business pay you (or your family living here) any rent for the use of the property?

1. YES

5. NO --> GO TO D7



D6a. How much rent do you (or your family living here) collect each month?
 \$ _____ PER _____

D7. Do you (or anyone in your family living here) pay any rent for this property?

1. YES

5. NO --> GO TO D8



D7a. How much rent do you (or your family living here) pay each month?
 \$ _____ PER _____

D8. I will ask you more about the business operation later. Now I'd like to ask about the part of the property that you (and your family living here) personally own. About what percent of the total property is that?

_____ PERCENT OR _____ ACRES

D9. Do you (or anyone in your family living here) own this house and the immediately surrounding land?

1. YES

5. NO --> GO TO D10



D9a. Could you tell me the present value of just this house and lot? I mean, about what would it bring if it were sold today?
 \$ _____

D10. Could you tell me the present value of the entire part of the property you own? I mean, what would it bring if it were sold today?

\$ _____

TURN TO P. 16, D20

D11. Now I have some questions about your home. Do you (or your family living here) own both this mobile home and site or lot, do you own only the mobile home, do you own only the site, do you rent both the home and site, or what?

- | | | | |
|---------------------------|------------------|----------------|---------------------------|
| 1. OWN BOTH HOME AND SITE | 3. OWN ONLY HOME | 4. RENT BOTH | 7. NEITHER OWNS NOR RENTS |
| NEXT PAGE, D14 | GO TO D12 | NEXT PAGE, D13 | |

2. OWN ONLY SITE

D11e. How is that? _____

D11f. In what month and year did you move into this mobile home? _____
 MONTH/YEAR

TURN TO P. 27, D68

D11a. About how much rent do you pay on this home each month? \$ _____ PER _____

D11b. Could you tell me the present value of the site? I mean, about what would it bring if it were sold today? \$ _____

D11c. In what month and year was this site purchased? _____
 MONTH/YEAR

D11d. How much did this site cost when it was purchased? \$ _____

GIFT/INHERITANCE

ASK VALUE WHEN RECEIVED

TURN TO P. 16, D22

R OWNS ONLY MOBILE HOME

D12. About how much rent do you pay on this site each month? \$ _____ PER _____

D12a. Could you tell me the present value of this mobile home? I mean, about what would it bring if it were sold today? \$ _____

D12b. In what month and year was this mobile home purchased? _____
 MONTH/YEAR

D12c. How much did this mobile home cost when it was purchased? \$ _____

GIFT/INHERITANCE

ASK VALUE WHEN RECEIVED

TURN TO P. 16, D22

R RENTS MOBILE HOME AND SITE

D13. About how much rent do you pay on this home and site each month? \$ _____ PER _____

D13a. In what month and year did you move into this mobile home?

 MONTH/YEAR

TURN TO P. 27, D68

R OWNS BOTH MOBILE HOME AND SITE

D14. Could you tell me the present value of this home and site? I mean, about what would they bring if they were sold today? \$ _____

D15. Were the site and mobile home purchased separately?

1. YES

5. NO

D15a. In what month and year was this mobile home purchased?

 MONTH/YEAR

D15b. How much did the mobile home cost when it was purchased?
 \$ _____

GIFT/INHERITANCE

ASK VALUE WHEN RECEIVED

D15c. In what month and year was this site purchased?

 MONTH/YEAR

D15d. How much did this site cost when it was purchased?
 \$ _____

GIFT/INHERITANCE

ASK VALUE WHEN RECEIVED

D15e. In what year and month was this mobile home and site purchased?

 MONTH/YEAR

D15f. How much did the mobile home and site cost when they were purchased?
 \$ _____

GIFT/INHERITANCE

ASK VALUE WHEN RECEIVED

TURN TO P. 16, D22

TURN TO P. 16, D22

D16. Now I have some questions about your home. Do you (and your family living here) own this (house and lot/apartment/farm/ranch), do you pay rent, do you own it as a part of a condo, co-op, townhouse association, or what?

1. OWNS OR IS BUYING; LAND CONTRACT	→	D16a. Is this a single family dwelling or does the building have more than one unit? <input type="checkbox"/> 1. SINGLE HU-->NEXT PAGE, D19 <input type="checkbox"/> 2. MULTIPLE HU-->NEXT PAGE, D18
2. PAYS RENT	→GO TO D17	
3. CONDO		D16b. How much are your (condo/co-op/townhouse association) fees? \$ _____ PER _____ <input type="checkbox"/> NONE NEXT PAGE, D19
4. CO-OP		
5. TOWNHOUSE ASSOC.	→	
7. NEITHER OWNS NOR RENTS	↓	

D16c. How is that? _____

IF ANYONE IN R'S FAMILY LIVING THERE APPEARS TO OWN ANY PART, MARK "1. OWNS OR IS BUYING" IN D16, FOLLOW SKIPS IN D16a

D16d. In what month and year did you move into this home?

 MONTH / YEAR

TURN TO P. 27, D68

R PAYS RENT

D17. How much rent do you pay a month for this (house/apartment/farm/ranch)?

\$ _____ PER _____

D17a. Does that include some or all utilities?
 1. YES, ALL 3. YES, SOME 5. NO

D17b. Do you rent it furnished or unfurnished?
 1. FURNISHED 3. PARTIALLY FURNISHED 5. UNFURNISHED

D17c. In what month and year did you move into this (house/apartment/farm/ranch)?

 MONTH/YEAR

TURN TO P. 27, D68

R LIVES IN MULTIPLE HU STRUCTURE

D18. Do you own the entire building or just your unit?

1. ENTIRE BUILDING

2. JUST R'S UNIT

---> The following questions about your home refer to your unit only. --->GO TO D19



D18a. The next few questions are about the entire property.
How many housing units are in this building?

_____ UNITS

D19. What is the present value of this (home and land/apartment/property)? I mean, about what would it bring if it were sold today?

(IWER: PROPERTY REFERS TO WHATEVER PART R OWNS OF THEIR HOUSE AND LOT, APARTMENT, BUILDING, FARM, RANCH, MOBILE HOME, AND SITE.)

\$ _____

D20. How much did it cost when it was purchased?

\$ _____

	GIFT/INHERITANCE
--	------------------

ASK VALUE WHEN RECEIVED

D21. In what month and year was it purchased?

MONTH/YEAR

D22. What are the real estate taxes per year on this (home and land/apartment/property)?

\$ _____ PER _____

DON'T KNOW

NONE

D23. Is there a mortgage or land contract on this (home and land/apartment/property)? (IF R ASKS, DO NOT INCLUDE HOME EQUITY LOANS OR LINES OF CREDIT)

1. YES, MORTGAGE

2. YES, LAND CONTRACT

5. NO

NEXT PAGE, D27, COL. A

TURN TO P.21, COL. B, D40a

IF R SAYS BOTH MORTGAGE AND LAND CONTRACT, FOLLOW MORTGAGE SEQUENCE.

D24. Is the first or main mortgage a federally guaranteed mortgage, such as FHA or VA?

1. YES

5. NO

8. DON'T KNOW

D24a. Does this mortgage carry any type of private mortgage insurance or PMI against default? (IF R ASKS: DO NOT INCLUDE MORTGAGE LIFE INSURANCE.)

1. YES

5. NO

NEXT PAGE, D27, COL. A

D25. Is it an FHA mortgage, a VA mortgage, or is it from some other program?

1. FHA

2. VA

7. OTHER: _____

D26. Why did you choose this type of loan?

NEXT PAGE, D27, COLUMN A

COLUMN A

COLUMN B

COLUMN C

	1ST MORTGAGE OR LAND CONTRACT	2ND MORTGAGE OR LAND CONTRACT	HOME EQUITY LOAN
D27. About the (mortgage/ land contract /second mortgage/other loan), in what month and year was it obtained or last refinanced?	_____ MONTH/YEAR	_____ MONTH/YEAR	_____ MONTH/YEAR
D27a. Was this (mortgage/ land contract) assumed from the previous owner?	1. YES 5. NO	1. YES 5. NO	
D28. How much was borrowed or refinanced?	\$ _____	\$ _____	\$ _____
D29. How much is still owed on this loan?	\$ _____	\$ _____	\$ _____
D30. How many years or payments were agreed upon when the loan was taken out or refinanced?	____ # YEARS OR ____ # PAYMENTS 96. NO SET # ↓ NEXT PAGE, D34 COLUMN A	____ # YEARS OR ____ # PAYMENTS 96. NO SET # ↓ NEXT PAGE, D34 COLUMN B	____ # YEARS OR ____ # PAYMENTS 96. NO SET # ↓ NEXT PAGE, D34 COLUMN C
D31. How much are the pay- ments and how often are they due?	\$ _____ PER _____ NO REG PYMNTS NEXT PAGE, D34	\$ _____ PER _____ NEXT PAGE, D33 COL. B NO REG PYMNTS NEXT PAGE, D34 COL. B	\$ _____ PER _____ NEXT PAGE, D33 COL. C NO REG PYMNTS NEXT PAGE, D34 COL. C
D32. Do the payments include property taxes or insurance? (Which?)	1. TAXES ONLY 2. INSURANCE ONLY 3. BOTH 4. NEITHER 8. DON'T KNOW		

NEXT PAGE,
D33, COL. A

	COLUMN A	COLUMN B	COLUMN C
	1ST MORTGAGE OR LAND CONTRACT	2ND MORTGAGE OR LAND CONTRACT	HOME EQUITY LOAN
D33. Will the regular payments repay the loan completely, or will there be a balance payable, or "balloon" payment, when the loan is due?	<div style="border: 1px solid black; padding: 5px; margin-bottom: 5px;">1. REPAY COMPLETELY</div> GO TO D35 <div style="border: 1px solid black; padding: 5px; margin-bottom: 5px;">2. BALLOON</div>	<div style="border: 1px solid black; padding: 5px; margin-bottom: 5px;">1. REPAY COMPLETELY</div> GO TO D35 <div style="border: 1px solid black; padding: 5px; margin-bottom: 5px;">2. BALLOON</div>	<div style="border: 1px solid black; padding: 5px; margin-bottom: 5px;">1. REPAY COMPLETELY</div> GO TO D35 <div style="border: 1px solid black; padding: 5px; margin-bottom: 5px;">2. BALLOON</div>
D33a. What will the balance due or balloon payment be?	\$ _____ GO TO D35	\$ _____ GO TO D35	\$ _____ GO TO D35
D34. What is the typical payment and how often is it made?	\$ _____ PER _____ <div style="border: 1px solid black; padding: 2px; display: inline-block;">NO TYPICAL PMNTS</div>	\$ _____ PER _____ <div style="border: 1px solid black; padding: 2px; display: inline-block;">NO TYPICAL PMNTS</div>	\$ _____ PER _____ <div style="border: 1px solid black; padding: 2px; display: inline-block;">NO TYPICAL PMNTS</div>
D34a. When do you expect this loan to be repaid?	_____ YEAR <div style="border: 1px solid black; padding: 2px; display: inline-block;">98. DON'T KNOW</div>	_____ YEAR <div style="border: 1px solid black; padding: 2px; display: inline-block;">98. DON'T KNOW</div>	_____ YEAR <div style="border: 1px solid black; padding: 2px; display: inline-block;">98. DON'T KNOW</div>
D35. What is the current annual rate of interest being charged on the loan?	_____%	_____%	_____%
	NEXT PAGE, D36, COL. A	NEXT PAGE, D36, COL. B	NEXT PAGE, D36, COL. C

COLUMN A

COLUMN B

COLUMN C

D36. (Please look at Card A.)
Is the loan with any of the institutions (you told me about at the beginning of the interview/on Card A), or from someplace else? (IF CARD A: Which institution? (IF SOMEPLACE ELSE: What type of institution is that?))

1ST MORTGAGE OR LAND CONTRACT		2ND MORTGAGE OR LAND CONTRACT		HOME EQUITY LOAN	
01. #1	04. #4	01. #1	04. #4	01. #1	04. #4
02. #2	05. #5	02. #2	05. #5	02. #2	05. #5
03. #3	06. #6	03. #3	06. #6	03. #3	06. #6
11. COMM. BANK		11. COMM. BANK		11. COMM. BANK	
12. S&L/SVNGS BNK		12. S&L/SAVNGS BNK		12. S&L/SAVNGS BNK	
14. FIN./LOAN CO.		14. FIN./LOAN CO.		14. FIN./LOAN CO.	
17. INSURANCE CO.		17. INSURANCE CO.		17. INSURANCE CO.	
18. MORTGAGE CO.		18. MORTGAGE CO.		18. MORTGAGE CO.	
19. CONTRACTOR DEVELOPER		19. CONTRACTOR DEVELOPER		19. CONTRACTOR DEVELOPER	
20. PRIOR OWNER		20. PRIOR OWNER		20. PRIOR OWNER	
97. OTHER: _____		97. OTHER: _____		97. OTHER: _____	

D37. Was the money from this loan used for the purchase of this home or for some other purpose? (What other purpose?)

	01. PURCHASE	01. PURCHASE
	97. OTHER: _____	97. OTHER: _____

D38. What is the most important reason you chose this lender? Was it because they were recommended to you, had low interest rates, because of the location of their offices, because you had done other business with them, because it was easier to qualify for the loan, or for some other reason?

01. RECOMMENDED				
02. LOW INTEREST				
03. LOCATION				
04. OTHER BUSINESS				
05. EASY TO QUALIFY				
97. OTHER: _____				

D39. Is this an adjustable rate (mortgage/loan); that is, does it have an interest rate that can rise or fall from time to time?

<div style="border: 1px solid black; padding: 2px; display: inline-block;">1. YES</div> <div style="border: 1px solid black; padding: 2px; display: inline-block; margin-left: 20px;">5. NO</div>	<div style="border: 1px solid black; padding: 2px; display: inline-block;">1. YES</div> <div style="border: 1px solid black; padding: 2px; display: inline-block; margin-left: 20px;">5. NO</div>	<div style="border: 1px solid black; padding: 2px; display: inline-block;">1. YES</div> <div style="border: 1px solid black; padding: 2px; display: inline-block; margin-left: 20px;">5. NO</div>
↓ NEXT PAGE D40, COL A	↓ NEXT PAGE, D40a, COL. B	↓ TURN TO P. 22, D41

NEXT PG. D39a, COL. A

COLUMN A

COLUMN B

1ST MORTGAGE OR
LAND CONTRACT

2ND MORTGAGE OR
LAND CONTRACT

D39a. Does the change in your interest rate depend on some other interest rate?

1. YES 5. NO 8. DK

GO TO D39c

D39b. On what other rate does it depend?

D39c. How often can your interest rate change?

PER

D39d. When the interest rate changes, will the size of your monthly payments change at the same time?

1. YES 5. NO

D39e. What is the most the rate can rise at any one time?
(POINTS - PERCENTAGE POINTS)

% / POINTS

9995. NO LIMIT

D39f. What is the highest the rate can go over the life of the loan?

%

9995. NO LIMIT

D39g. What was the interest rate on this mortgage when you first got it?

%

D39m. Is this a convertible mortgage; that is do you have an option to convert it to a mortgage with a fixed interest rate?

1. YES 5. NO

D40. Do you have a second mortgage or a land contract on this property?
(Please do not include any home equity lines of credit.)

1. YES, 2ND MTG GO BACK
2. YES, LND CON TO P. 18
5. NO D27,
COL. B

D40a.

Do you have any (other) loans that use this property as collateral?
(Please do not include any home equity lines of credit.)

1. YES -->P. 18, D27, COLUMN C

5. NO --->NEXT PAGE, D41

IWER: A HOME EQUITY LINE OF CREDIT IS AN AGREEMENT WHERE THE R CAN BORROW AT ANY TIME USING THE HOUSE AS COLLATERAL, UP TO SOME LIMIT.

A HOME EQUITY LOAN IS A FIXED LENGTH, FIXED MONTHLY PAYMENT LOAN.

D41. Do you (and your family living here) owe money on any (other) loans used for the purchase of this property, such as loans from relatives or the seller? (Please do not include any home equity lines of credit.)

1. YES

5. NO --> NEXT PAGE, D52

D42. In what month and year was this loan taken out?

MONTH/YEAR

D43. How much was borrowed, not including finance charges?

\$ _____

D44. Is this a regular installment loan where you pay a fixed dollar amount each month for a fixed number of months until the loan is repaid, or some other kind?

1. REGULAR INSTALLMENT

2. OTHER KIND

8. DK

D45. How many monthly payments or years were agreed upon when the loan was received?

_____ # PYMNTS OR _____ # YEARS

996. NO SET #

998. DK

D46. How much are the monthly payments?

\$ _____ PER MO

9996. NO REGULAR PYMTS

D47. What is the typical payment, and how often is it made?

\$ _____ PER _____

9996. NO TYPICAL PAYMENTS

D48. In what month and year do you expect this loan to be repaid?

_____ MONTH / YEAR

D49. How much is still owed on this loan?

\$ _____

D50. What is the current annual rate of interest being charged on this loan?

_____ %

D51. (Please look at Card A.) Is the loan with any of the institutions (you told me about at the beginning of the interview/on Card A), or from someplace else? (IF CARD A: Which institution?) (IF SOMEPLACE ELSE: What type of institution is that?)

- | | | | | | |
|-----------------|-------------------|------------------|--------------------|-----------------|--------------|
| 01. INST. #1 | 02. INST. #2 | 03. INST. #3 | 04. INST. #4 | 05. INST. #5 | 06. INST. #6 |
| 11. COMM'L BANK | 12. S&L/SVGS BANK | 13. CREDIT UNION | 14. FIN./ LOAN CO. | 97. OTHER _____ | |

D52. Do you (or anyone in your family living here) have a home equity line of credit, or any other lines of credit, not counting credit cards or business lines of credit? Please include such lines of credit even if you are not currently drawing against them.

(IF R ASKS: A LINE OF CREDIT IS A FORMAL AGREEMENT WITH A LENDER THAT ALLOWS R TO BORROW UP TO AN AGREED UPON LIMIT AND PAY IT OFF AS R DESIRES. A HOME EQUITY LINE OF CREDIT IS A LINE OF CREDIT SECURED BY THE EQUITY IN R'S HOME.)

1. YES

5. NO → TURN TO P. 25, D54

v

D53. How many lines of credit do you (and your family living here) have?

LINES OF CREDIT

	LINE OF CREDIT #1	LINE OF CREDIT #2	LINE OF CREDIT #3
D53a. Is (this/ the largest/next) line of credit secured by the equity in your home?	1. YES 5. NO	1. YES 5. NO	1. YES 5. NO
D53b. What is the <u>maximum</u> amount you could borrow on this line of credit?	\$ _____	\$ _____	\$ _____
D53c. Are you currently borrowing any money against this line of credit?	1. YES 5. NO v NEXT PAGE D53h, LOC#1	1. YES 5. NO v NEXT PAGE D53h, LOC#2	1. YES 5. NO v NEXT PAGE D53h, LOC#3
D53d. What was the money used for? (What was its major use?)	_____	_____	_____
D53e. How much is currently owed?	\$ _____	\$ _____	\$ _____
D53f. What is the typical payment and how often is it made?	\$ _____ PER _____ NO TYPICAL PAYMENTS	\$ _____ PER _____ NO TYPICAL PAYMENTS	\$ _____ PER _____ NO TYPICAL PAYMENTS
D53g. What is the current annual rate of int- erest being charged on this loan?	_____ %	_____ %	_____ %

D53h. (Please look at Card A.) Is this line of credit with any of the institutions (you told me about at the beginning of the interview/on Card A), or from someplace else? (IF CARD A: Which institution?) (IF SOMEPLACE ELSE: What type of institution is that?)

LINE OF CREDIT #1		LINE OF CREDIT #2		LINE OF CREDIT #3	
01. # 1	04. # 4	01. # 1	04. # 4	01. # 1	04. # 4
02. # 2	05. # 5	02. # 2	05. # 5	02. # 2	05. # 5
03. # 3	06. # 6	03. # 3	06. # 6	03. # 3	06. # 6
11. COMM. BANK		11. COMM. BANK		11. COMM. BANK	
12. S&L/ SAV BANK		12. S&L/ SAV BANK		12. S&L/ SAV BANK	
13. CREDIT UNION		13. CREDIT UNION		13. CREDIT UNION	
14. FIN; LOAN CO		14. FIN; LOAN CO		14. FIN; LOAN CO	
16. BROKERAGE		16. BROKERAGE		16. BROKERAGE	
97. OTHER: _____		97. OTHER: _____		97. OTHER: _____	
<input type="checkbox"/> 1. <u>ONLY</u> 1 LOC; NEXT PAGE, D54		<input type="checkbox"/> 1. <u>ONLY</u> 2 LOC's NEXT PAGE, D54		<input type="checkbox"/> 1. <u>ONLY</u> 3 LOC's NEXT PAGE, D54	
<input type="checkbox"/> 2. ALL OTHERS GO BACK TO D53a, LOC #2		<input type="checkbox"/> 2. ALL OTHERS GO BACK TO D53a, LOC #3		<input type="checkbox"/> 2. ALL OTHERS	

D53k. INTERVIEWER CHECKPOINT (SEE D53, P. 23)

D53m. What is the total amount that you (and your family living here) currently owe on all other remaining lines of credit?

\$ _____

D54. Have you (and your family living here) ever made any major additions or done extensive remodeling to this property?

1. YES

5. NO --> NEXT PAGE, D66

D54a. Roughly what was the total cost of all such major additions or remodeling? \$ _____

D54b. Other than what I have already recorded, do you (or your family living here) owe any money on loans taken out for these projects?

1. YES

5. NO --> NEXT PAGE, D66

V

D55. In what month and year was the most recent such loan taken out? _____
MONTH/YEAR

D56. How much was borrowed, not including finance charges? \$ _____

D57. Is this a regular installment loan where you pay a fixed dollar amount each month for a fixed number of months until the loan is repaid, or some other kind?

1. REGULAR INSTALLMENT

2. OTHER KIND

8. DON'T KNOW

D58. How many monthly payments or years were agreed upon when the loan was received?

PYMNTS OR # YEARS

996. NO SET #

998. DK

D59. How much are the monthly payments?

\$ _____ PER MO

9996. NO REGULAR PYMNTS

D60. What is the typical payment, and how often is it made?

\$ _____ PER _____

9996. NO TYPICAL PAYMENT

D61. In what month and year do you expect this loan to be repaid?

_____ / _____
MONTH / YEAR

D62. How much is still owed on this loan?

\$ _____

D63. What is the current annual rate of interest being charged on this loan?

_____ %

D64. (Please look at Card A.) Is the loan with any of the institutions (you told me about at the beginning of the interview/on Card A), or from someplace else?
 (IF CARD A: Which institution?)
 (IF SOMEPLACE ELSE: What type of institution is that?)

01. INST. #1	02. INST. #2	03. INST. #3	04. INST. #4	05. INST. #5	06. INST. #6
11. COMM'L BANK	12. S&L/SVGS BANK	13. CREDIT UNION	14. FIN./ LOAN CO.	97. OTHER _____	

D65. Do you owe money on more than one loan for home additions or improvements?

1. YES 5. NO -->GO TO D66

↓

D65a. Altogether, how much is still owed on other loans for additions or improvements?
 \$ _____

D65b. Altogether, how much are the monthly payments?
 \$ _____ PER _____

↓

D66. INTERVIEWER CHECKPOINT

SEE P. 10, D1

1. R LIVES ON A RANCH OR FARM --> TURN TO P. 29, SECTION E

2. ALL OTHERS

↓

D67. Do you or anyone in your family here) rent out any portion of this (house or lot/apartment/mobile home/building) to others?

1. YES 5. NO -->TURN TO P. 29, SECTION E

↓

D67a. How much rent do you collect each month?
 \$ _____ PER _____

TURN TO P. 29, SECTION E

D68. Do you (or anyone in your family living here) have any lines of credit, not counting credit cards or business lines of credit? Please include such lines of credit even if you are not currently drawing against them.

(IF R ASKS: A LINE OF CREDIT IS A FORMAL AGREEMENT WITH A LENDER THAT ALLOWS R TO BORROW UP TO A SPECIFIED LIMIT AND PAY IT OFF AS R DESIRES.)

1. YES 5. NO --> TURN TO P. 29, SECTION E

D68a. Altogether, what is the maximum amount you could borrow on these lines of credit?

\$ _____

D68b. Are you currently borrowing any money against such lines of credit?

1. YES 5. NO

D68c. (Please look at Card A.) Are these lines of credit with any of the institutions (you told me about at the beginning of the interview/on Card A), or from someplace else? (CHECK ALL THAT APPLY.)
 (IF CARD A: Which institutions?)
 (IF SOMEPLACE ELSE: What types of institutions are they?)

01. #1	02. #2	03. #3	04. #4	05. #5	06. #6
11. COMM. BANK	12. S&L/ SAV BANK	13. CREDIT UNION			
14. FIN; LOAN CO	16. BROKERAGE	97. OTHER: _____			

TURN TO P. 29, SECTION E

D68d. How many such lines of credit are you currently borrowing against?

_____ # LINES OF CREDIT (LOC)

ENTER # OF LINES OF CREDIT AT D69, ON TOP OF NEXT PAGE

D69. # LINES OF CREDIT (LOC)

	LINE OF CREDIT #1	LINE OF CREDIT #2	LINE OF CREDIT #3
D70. What was the (largest/next) line of credit used for? (What was its major use?)	_____ _____ _____	_____ _____ _____	_____ _____ _____
D71. How much is currently owed?	\$ _____	\$ _____	\$ _____
D72. What is the typical payment and how often is it made?	\$ _____ PER _____ <div style="border: 1px solid black; padding: 2px; text-align: center;">9996. NO TYPICAL PAYMENTS</div>	\$ _____ PER _____ <div style="border: 1px solid black; padding: 2px; text-align: center;">9996. NO TYPICAL PAYMENTS</div>	\$ _____ PER _____ <div style="border: 1px solid black; padding: 2px; text-align: center;">9996. NO TYPICAL PAYMENTS</div>
D73. What is the current annual rate of interest being charged on this loan?	_____ %	_____ %	_____ %
D74. (Please look at Card A.) Is the line of credit with any of the institutions (you told me about at the beginning of the interview/on Card A), or from someplace else? (IF CARD A: Which institution?) (IF SOMEPLACE ELSE: What type of institution is that?)	01. # 1 04. # 4	01. # 1 04. # 4	01. # 1 04. # 4
	02. # 2 05. # 5	02. # 2 05. # 5	02. # 2 05. # 5
	03. # 3 06. # 6	03. # 3 06. # 6	03. # 3 06. # 6
	11. COMM. BANK	11. COMM. BANK	11. COMM. BANK
	12. S&L/ SAV BANK	12. S&L/ SAV BANK	12. S&L/ SAV BANK
	13. CREDIT UNION	13. CREDIT UNION	13. CREDIT UNION
	14. FIN; LOAN CO	14. FIN; LOAN CO	14. FIN; LOAN CO
	16. BROKERAGE	16. BROKERAGE	16. BROKERAGE
	97. OTHER: _____	97. OTHER: _____	97. OTHER: _____
	_____	_____	_____
D75. INTERVIEWER CHECKPOINT (SEE D69)	<input type="checkbox"/> <u>ONLY 1 LOC;</u> 1. NEXT PAGE, SECTION E <input type="checkbox"/> 2. ALL OTHERS GO BACK TO D70, LOC #2	<input type="checkbox"/> <u>ONLY 2 LOC's</u> 1. NEXT PAGE, SECTION E <input type="checkbox"/> 2. ALL OTHERS GO BACK TO D70, LOC #3	<input type="checkbox"/> <u>ONLY 3 LOC's</u> 1. NEXT PAGE, SECTION E <input type="checkbox"/> 2. ALL OTHERS <div style="text-align: center;">↓</div>

D76. What is the total amount that you (and your family living here) currently owe on all remaining such lines of credit?

\$ _____

SECTION E: OTHER PROPERTIES, LAND CONTRACTS

E1. Have you (or anyone in your family living here) ever sold real estate for which you loaned money to the buyer? Please include accepting a note, land contract or mortgage from the buyer. (IF YES, SAY: We do not want to include any property owned by a business which you own or have an interest in.)

1. YES 5. NO --> TURN TO P. 31, E14

E2. Does the buyer still owe (you/your family) money on any of these notes, land contracts, or mortgages?

1. YES 5. NO --> TURN TO P. 31, E14

E2a. Altogether, on how many such loans (are you/is your family) owed money?

NOTES/LAND CONTRACTS/MORTGAGES

E3. (About the [largest/next] loan ...) Is it a land contract, a mortgage, or a note?

	LOAN/LAND CONTRACT #1	LOAN/LAND CONTRACT #2	LOAN/LAND CONTRACT #3
	1. LAND CONTRACT	1. LAND CONTRACT	1. LAND CONTRACT
	2. MORTGAGE	2. MORTGAGE	2. MORTGAGE
	GO TO E5	GO TO E5	GO TO E5
	3. NOTE	3. NOTE	3. NOTE
E4. How much are you (and your family) owed on this note?	\$ _____ NEXT PAGE, E11	\$ _____ NEXT PAGE, E11	\$ _____ NEXT PAGE, E11
E5. In what month and year was this (mortgage/land contract) taken out?	_____ MONTH/YEAR	_____ MONTH/YEAR	_____ MONTH/YEAR
E6. How much did (you/your family) lend the borrower?	\$ _____	\$ _____	\$ _____
E7. How much is still owed on this (mortgage/land contract)?	\$ _____	\$ _____	\$ _____

NEXT PAGE, E8
COL. 1

NEXT PAGE, E8
COL. 2

NEXT PAGE, E8
COL. 3

	LOAN/ L.C. #1	LOAN/ L.C. #2	LOAN/ L.C. #3
E8. How much are the (mortgage/land contract) payments and how often are they due?	\$ _____ PER _____ NO REG PAY GO TO E11	\$ _____ PER _____ NO REG PAY GO TO E11	\$ _____ PER _____ NO REG PAY GO TO E11
E9. How many years or payments were agreed upon when the (mortgage/land contract) was taken out?	_____ # YRS OR _____ # PYMTS 96. NO SET NUM	_____ # YRS OR _____ # PYMTS 96. NO SET NUM	_____ # YRS OR _____ # PYMTS 96. NO SET NUM
E10. Will the regular payments pay off the (mortgage/land contract) completely or will there be a balance payable or "balloon" when the (mortgage/land contract) is due?	1. REPAY COMPLETELY GO TO E11 5. BALLOON	1. REPAY COMPLETELY GO TO E11 5. BALLOON	1. REPAY COMPLETELY GO TO E11 5. BALLOON
E10a. What will the balance payable or balloon payment be?	\$ _____	\$ _____	\$ _____
E11. Do you (or your family living here) still owe any money on loans for this property?	1. YES 5. NO GO TO E12	1. YES 5. NO GO TO E12	1. YES 5. NO GO TO E12
E11a. How much do you still owe?	\$ _____	\$ _____	\$ _____
E12. INTERVIEWER CHECKPOINT (SEE E2a, P. 29)	<input type="checkbox"/> 1. ONLY 1 LOAN/LC--> NEXT PAGE, E14 <input type="checkbox"/> 2. ALL OTHERS GO BACK TO P. 29, E3, COL #2	<input type="checkbox"/> 1. ONLY 2 LOANS/LC--> NEXT PAGE, E14 <input type="checkbox"/> 2. ALL OTHERS GO BACK TO P. 29, E3, COL #3	<input type="checkbox"/> 1. ONLY 3 LOANS/LC--> NEXT PAGE, E14 <input type="checkbox"/> 2. ALL OTHERS

E13. About how much in total is owed to (you/your family) on the remaining notes, land contracts or mortgages?
\$ _____

E13a. Do you (or your family here) still owe any money on loans for these other properties?

1. YES 5. NO → NEXT PAGE, E14

E13b. Altogether how much (do you/does your family) still owe? \$ _____

E14. Do you (or anyone in your family living here) own any (other) real estate such as a lot, vacation home, apartment building, commercial property, including properties owned in partnership with other people? (IF YES SAY: We do not want to include any property owned by a business that you have an interest in, or any limited partnerships.)

1. YES

5. NO

--> TURN TO P. 36, SECTION G



E15. How many such properties do you (and your family living here) own or have an interest in?

PROPERTIES

E16. (About the [largest/next] property..) What type of property is this?

E17. Is this property owned by you (and your family living here), is it owned jointly with others, owned by a partnership, or what?

E17a. What percentage of the property do you (and your family living here) own?

E18. How much in total is this property worth; I mean what would it bring if it were sold today?

(WE WANT THE TOTAL VALUE NOT JUST R'S SHARE. FOR E18-E29, NOTE IF R ONLY KNOWS THEIR SHARE.)

	PROPERTY # 1	PROPERTY # 2	PROPERTY # 3
	<hr/> <hr/> <hr/>	<hr/> <hr/> <hr/>	<hr/> <hr/> <hr/>
	1. OWNED BY R GO TO E18	1. OWNED BY R GO TO E18	1. OWNED BY R GO TO E18
	2. OWNED JOINTLY	2. OWNED JOINTLY	2. OWNED JOINTLY
	3. PARTNERSHIP	3. PARTNERSHIP	3. PARTNERSHIP
	4. REAL ESTATE INVEST TRUST	4. REAL ESTATE INVEST TRUST	4. REAL ESTATE INVEST TRUST
	7. OTHER _____ _____	7. OTHER _____ _____	7. OTHER _____ _____
	100. ALL _____ PERCENT	100. ALL _____ PERCENT	100. ALL _____ PERCENT
	\$ _____	\$ _____	\$ _____

NEXT PAGE, E19
COL. 1

NEXT PAGE, E19
COL. 2

NEXT PAGE, E19
COL. 3

	PROPERTY # 1	PROPERTY # 2	PROPERTY # 3
E19. In what month and year was the property acquired? (When did R acquire it?)	_____ MONTH/YEAR	_____ MONTH/YEAR	_____ MONTH/YEAR
E20. What was the <u>total</u> purchase price? (IF GIFT/INHERITANCE, ASK: VALUE WHEN RECEIVED)	\$ _____ GIFT/INHER.	\$ _____ GIFT/INHER.	\$ _____ GIFT/INHER.
E21. Are there any outstanding loans or mortgages on this property?	1. YES 5. NO ↓ TURN TO P. 34, E34	1. YES 5. NO ↓ TURN TO P. 34, E34	1. YES 5. NO ↓ TURN TO P. 34, E34
E22. In what month and year was the loan obtained or last refinanced?	_____ MONTH/YEAR	_____ MONTH/YEAR	_____ MONTH/YEAR
E23. How much was borrowed or refinanced?	\$ _____	\$ _____	\$ _____
E24. How much is still owed?	\$ _____	\$ _____	\$ _____
E25. How many years or payments were agreed upon when the loan was taken out?	____ # YEARS OR ____ # PYMNTS ↓ 96. NO SET NUMBER ↓ 98. DK NEXT PG, E29	____ # YEARS OR ____ # PYMNTS ↓ 96. NO SET NUMBER ↓ 98. DK NEXT PG, E29	____ # YEARS OR ____ # PYMNTS ↓ 96. NO SET NUMBER ↓ 98. DK NEXT PG, E29
E26. How much are the payments and how often are they due?	\$ _____ ↓ PER _____ NO REG PYMNTS NEXT PAGE, E29	\$ _____ ↓ PER _____ NO REG PYMNTS NEXT PAGE, E29	\$ _____ ↓ PER _____ NO REG PYMNTS NEXT PAGE, E29
E27. Do the payments include property taxes or insurance? (Which?)	1. TAXES 2. INSUR. 3. BOTH 4. NEITHR	1. TAXES 2. INSUR. 3. BOTH 4. NEITHR	1. TAXES 2. INSUR. 3. BOTH 4. NEITHR
	NEXT PAGE, E28 COL. 1	NEXT PAGE, E28 COL. 2	NEXT PAGE, E28 COL. 3

	PROPERTY #1	PROPERTY #2	PROPERTY #3
E28. Will the regular payments repay the loan completely or will there be a balance payable, or "balloon" payment when the loan is due?	1. REPAY COMPLETELY GO TO E31 5. BALLOON	1. REPAY COMPLETELY GO TO E31 5. BALLOON	1. REPAY COMPLETELY GO TO E31 5. BALLOON
E28a. What will the balance due or balloon payment be?	\$ _____ GO TO E31	\$ _____ GO TO E31	\$ _____ GO TO E31
E29. What is the typical payment and how often is it made?	\$ _____ PER _____ NO TYPICAL PAYMENTS	\$ _____ PER _____ NO TYPICAL PAYMENTS	\$ _____ PER _____ NO TYPICAL PAYMENTS
E30. When do you expect this loan to be repaid?	_____ YEAR	_____ YEAR	_____ YEAR
E31. What is the current annual interest rate being charged on the loan?	_____ %	_____ %	_____ %
E32. Does this loan have an adjustable rate; that is does it have an interest rate that can rise and fall from time to time?	1. YES 5. NO	1. YES 5. NO	1. YES 5. NO
E33. (Please look at Card A.) Is this loan with any of the institutions (you told me about at the beginning of the interview/on Card A), or from someplace else? (IF CARD A: Which institution?) (IF SOMEPLACE ELSE: What type of institution is that?)	01. #1 04. #4	01. #1 04. #4	01. #1 04. #4
	02. #2 05. #5	02. #2 05. #5	02. #2 05. #5
	03. #3 06. #6	03. #3 06. #6	03. #3 06. #6
	11. COMM. BANK	11. COMM. BANK	11. COMM. BANK
	12. S&L/ SAV BANK	12. S&L/ SAV BANK	12. S&L/ SAV BANK
	13. CREDIT UNION	13. CREDIT UNION	13. CREDIT UNION
	18. MORTGAGE CO.	18. MORTGAGE CO.	18. MORTGAGE CO.
	19. CONTRACTOR; DEVELOPER	19. CONTRACTOR; DEVELOPER	19. CONTRACTOR; DEVELOPER
	20. PRIOR OWNER	20. PRIOR OWNER	20. PRIOR OWNER
	97. OTHER: _____	97. OTHER: _____	97. OTHER: _____
	NEXT PAGE, E34 COL. 1	NEXT PAGE, E34 COL. 2	NEXT PAGE, E34 COL. 3

	PROPERTY #1	PROPERTY #2	PROPERTY #3
E34. Did (you/your family living here) receive any income from this property in 1988?	<input type="checkbox"/> 1. YES <input type="checkbox"/> 5. NO GO TO E35	<input type="checkbox"/> 1. YES <input type="checkbox"/> 5. NO GO TO E35	<input type="checkbox"/> 1. YES <input type="checkbox"/> 5. NO GO TO E35
E34a. How much <u>gross</u> income did (you/your family) receive?	\$ _____ IN '88	\$ _____ IN '88	\$ _____ IN '88
E35. INTERVIEWER CHECKPOINT (SEE E15, P. 31)	<input type="checkbox"/> 1. <u>ONLY 1</u> PROPERTY, TURN TO P. 36, SECTION G	<input type="checkbox"/> 1. <u>ONLY 2</u> PROPERTIES TURN TO P. 36, SECTION G	<input type="checkbox"/> 1. <u>ONLY 3</u> PROPERTIES TURN TO P. 36, SECTION G
	<input type="checkbox"/> 2. ALL OTHERS GO BACK TO PROP. #2 P.31, E16	<input type="checkbox"/> 2. ALL OTHERS GO BACK TO PROP. #3 P. 31, E16	<input type="checkbox"/> 2. ALL OTHERS ↓

E36. About the remaining properties that you (and your family living here) own, are any of these vacation homes or land you use for recreational purposes?

1. YES 5. NO --> NEXT PAGE, E37
 ↓

E36a. How much in total is your (family's) share of these vacation homes or recreational property worth?

\$ _____

E36b. What was your (family's) total purchase price for these properties?

\$ _____

	GIFT/INHERITANCE
--	------------------

ASK VALUE WHEN RECEIVED

E36c. Are there any mortgages or loans outstanding against these vacation homes or recreational land?

1. YES 5. NO --> NEXT PAGE, E36f
 ↓

E36d. Altogether, about how much is owed on your (family's) share of these mortgages or loans?

\$ _____

E36e. How much are the payments on these loans or mortgages and how often are they due?

\$ _____ PER _____

NO REGULAR PAYMENT

E36f. Did you (or your family living here) receive any income in 1988 from renting out these vacation homes or recreational land?

1. YES

5. NO

--> GO TO E36h

E36g. Altogether, how much gross income did (you/your family) receive?

\$ _____

E36h. Are there any remaining properties you own that you have not told me details about?

1. YES

5. NO

--> NEXT PAGE, SECTION G

E37. For the remaining properties that you own, about how much in total is your (family's) share worth? I mean, what could you sell them for?

\$ _____

E37a. About how much was your (family's) total purchase price for these properties?

\$ _____

GIFT/INHERITANCE

ASK VALUE WHEN RECEIVED

E37b. Are there mortgages or loans outstanding against these properties?

1. YES

5. NO

--> GO TO E37e

E37c. Altogether, about how much is owed on your (family's) share of these mortgages or loans?

\$ _____

E37d. How much are the payments on these loans or mortgages and how often are they due?

\$ _____ PER _____

NO REGULAR PAYMENT

E37e. Did you (or your family living here) receive any income in 1988 from renting out any of these other properties?

1. YES

5. NO

--> NEXT PAGE, SECTION G

E37f. Altogether, how much gross income did (you/your family) receive in 1988?

\$ _____

SECTION G: VEHICLES

G1. Are you (or anyone in your family living here) currently leasing any cars or other vehicles? (IF YES, SAY: Do not include any vehicle that is leased by a business.)

1. YES

5. NO --> NEXT PAGE, G7



G2. Altogether, how many cars or other vehicles do you (and your family living here) lease?

LEASED VEHICLES

G3. What make and model is the (newest/next) vehicle? (2-WORD ANSWER: MAKE AND MODEL)

VEHICLE #1	VEHICLE #2
_____/_____ MAKE/MODEL	_____/_____ MAKE/MODEL

G4. What model year is it?

_____ YEAR	_____ YEAR
------------	------------

G5. How much are your monthly lease payments?

\$ _____ PER _____	\$ _____ PER _____
--------------------	--------------------

G5a. How many years or months was the original lease?

_____ YRS OR _____ MOS	_____ YRS OR _____ MOS
------------------------	------------------------

G6. INTERVIEWER CHECKPOINT (SEE G2)

<input type="checkbox"/> 1. <u>ONLY</u> 1 VEHICLE NEXT PAGE, G7	<input type="checkbox"/> 1. <u>ONLY</u> 2 VEHICLES NEXT PAGE, G7
<input type="checkbox"/> 2. ALL OTHERS --> GO BACK TO G2, VH #2	<input type="checkbox"/> 2. ALL OTHERS



G6a. Altogether, about how much per month are the lease payments on your other leased vehicle(s)?

\$ _____ PER _____

G7. Do you (or anyone in your family here) own any cars, or any kind of truck, van, or jeep-type vehicle? Do not include vehicles owned by a business.

1. YES

5. NO -->TURN TO P. 40, G24



G7a. Altogether, how many such cars or other vehicles do you (and your family living here) own?

OWNED VEHICLES

G8. What type of vehicle is (it/the newest/the next)-- (a car, van, jeep, pickup, or what?)

	VEHICLE #1	VEHICLE #2	VEHICLE #3
	<input type="text"/> 1. CAR <input type="text"/> 2. VAN <input type="text"/> 3. JEEP <input type="text"/> 4. PICKUP <input type="text"/> 7. OTHER: _____	<input type="text"/> 1. CAR <input type="text"/> 2. VAN <input type="text"/> 3. JEEP <input type="text"/> 4. PICKUP <input type="text"/> 7. OTHER: _____	<input type="text"/> 1. CAR <input type="text"/> 2. VAN <input type="text"/> 3. JEEP <input type="text"/> 4. PICKUP <input type="text"/> 7. OTHER: _____
G9. What make and model is it? (2-WORD ANSWER: MAKE <u>AND</u> MODEL)	_____/_____ MAKE/MODEL	_____/_____ MAKE/MODEL	_____/_____ MAKE/MODEL
G10. What model year is it?	_____ YEAR	_____ YEAR	_____ YEAR
G11. Not counting any loans I've already recorded, is any money still owed on loans for this (MAKE/MODEL)?	<input type="text"/> 1. YES <input type="text"/> 5. NO ↓ GO BACK TO G8 FOR VEH. #2 OR TURN TO P. 40, G24	<input type="text"/> 1. YES <input type="text"/> 5. NO ↓ GO BACK TO G8 FOR VEH. #3 OR TURN TO P. 40, G24	<input type="text"/> 1. YES <input type="text"/> 5. NO ↓ TURN TO P. 39, G23 COL. 3
G12. QUESTION OMITTED	↓	↓	↓
G13. In what month and year was the loan taken out?	_____ MONTH/YEAR	_____ MONTH/YEAR	_____ MONTH/YEAR

NEXT PAGE, G14
COL. 1

NEXT PAGE, G14
COL. 2

NEXT PAGE, G14
COL. 3

G14. How much was borrowed or financed?

VEHICLE #1
\$ _____

VEHICLE #2
\$ _____

VEHICLE #3
\$ _____

G15. Is this a regular installment loan where you pay a fixed dollar amount each month for a fixed number of months until the loan is repaid, or some other kind?

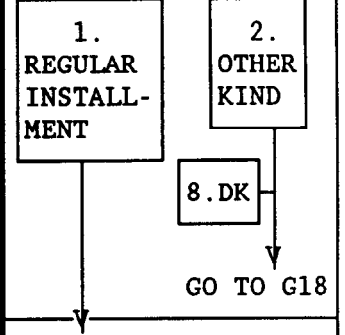
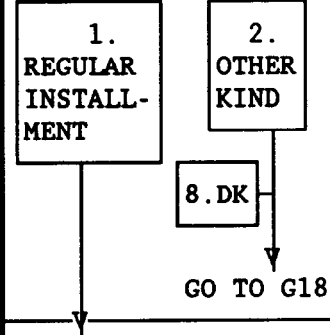
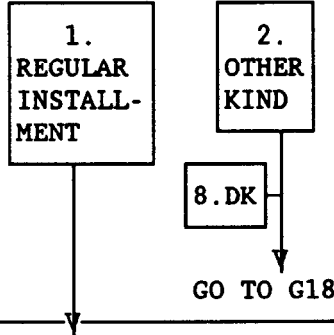

G16. How many monthly payments or years were agreed upon when the loan was received?

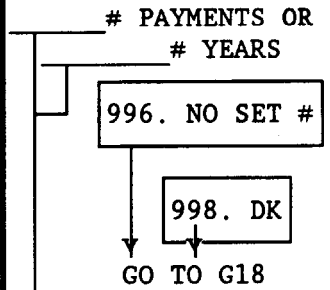
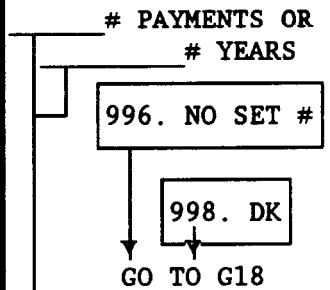
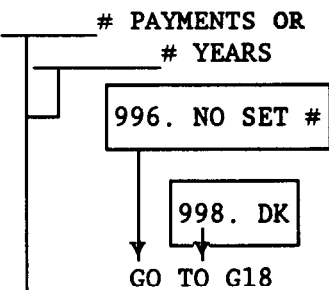

G17. How much are the monthly payments?

VEHICLE #1
\$ _____ PER MONTH
GO TO G21

VEHICLE #2
\$ _____ PER MONTH
GO TO G21

VEHICLE #3
\$ _____ PER MONTH
GO TO G21

9996. NO REGULAR PAYMENTS

9996. NO REGULAR PAYMENTS

9996. NO REGULAR PAYMENTS

G18. What is the typical payment and how often is it made?

VEHICLE #1
\$ _____ PER _____
9996. NO TYPICAL PAYMENT

VEHICLE #2
\$ _____ PER _____
9996. NO TYPICAL PAYMENT

VEHICLE #3
\$ _____ PER _____
9996. NO TYPICAL PAYMENT

G19. In what month and year do you expect this loan to be repaid?

VEHICLE #1
MONTH/YEAR 98.DK

VEHICLE #2
MONTH/YEAR 98.DK

VEHICLE #3
MONTH/YEAR 98.DK

G20. How much is still owed on this loan?

VEHICLE #1
\$ _____

VEHICLE #2
\$ _____

VEHICLE #3
\$ _____

G21. What is the current annual rate of interest being charged on this loan?

VEHICLE #1
_____ %

VEHICLE #2
_____ %

VEHICLE #3
_____ %

NEXT PAGE, G22
COL. 1

NEXT PAGE, G22
COL. 2

NEXT PAGE, G22
COL. 3

G22. (Please look at Card A.) Is the loan with any of the institutions (you told me about at the beginning of the interview/on Card A), or from someplace else? (IF CARD A: Which institution?) (IF SOMEPLACE ELSE: What type of institution is that?)

VEHICLE #1		VEHICLE #2		VEHICLE #3	
01. #1	04. #4	01. #1	04. #4	01. #1	04. #4
02. #2	05. #5	02. #2	05. #5	02. #2	05. #5
03. #3	06. #6	03. #3	06. #6	03. #3	06. #6
11. COMM. BANK		11. COMM. BANK		11. COMM. BANK	
12. S&L/ SAV BANK		12. S&L/ SAV BANK		12. S&L/ SAV BANK	
13. CREDIT UNION		13. CREDIT UNION		13. CREDIT UNION	
14. FIN; LOAN CO		14. FIN; LOAN CO		14. FIN; LOAN CO	
15. DEALER		15. DEALER		15. DEALER	
20. PRIOR OWNER		20. PRIOR OWNER		20. PRIOR OWNER	
21. AUTO FINANCE/ GMAC/ FORD CDT		21. AUTO FINANCE/ GMAC/ FORD CDT		21. AUTO FINANCE/ GMAC/ FORD CDT	
97. OTHER: _____		97. OTHER: _____		97. OTHER: _____	
<input type="checkbox"/> 1. <u>ONLY</u> 1 VEH. NEXT PAGE, G24 <input type="checkbox"/> 2. ALL OTHERS BACK TO P. 37, G8, VEH. #2		<input type="checkbox"/> 1. <u>ONLY</u> 2 VEH. NEXT PAGE, G24 <input type="checkbox"/> 2. ALL OTHERS BACK TO P. 37, G8, VEH. #3		<input type="checkbox"/> 1. <u>ONLY</u> 3 VEH. NEXT PAGE, G24 <input type="checkbox"/> 2. ALL OTHERS	

G23. INTERVIEWER CHECKPOINT (SEE G7a, P. 37)

G23a. How much (is/are all) the other such vehicle(s) that you (and others in your family living here) own worth in today's prices?

\$ _____

DON'T KNOW

G23b. Not counting loans I have already recorded, is any money still owed on loans for (this/these) vehicle(s)?

1. YES
 5. NO → NEXT PAGE, G24

G23c. Altogether, about how much is still owed on (this/these) loan(s)? (ACCEPT RANGE.)

\$ _____

G23d. How much are the total monthly payments on (this/these) loans?

\$ _____ PER _____

G24. Do you (or anyone in your family living here) have any (other) vehicles that are owned by a business but which you also use regularly for personal purposes?

1. YES

5. NO --> GO TO G25



G24a. How many such vehicles do you (or someone in your family living here) regularly use?

_____ # BUSINESS VEHICLES

G25. Do you (or anyone in your family here) own any other vehicles such as a motorhome, RV, boat, or airplane?

1. YES

5. NO --> TURN TO P. 44, SECTION H

NEXT PAGE, G25a

G25a. Altogether, how many of these other vehicles do you (and your family living here) own?

VEHICLES

G26. What type of vehicle is (it/the newest/the next)-- (Is it a motorhome, RV, airplane, boat, or what?)

VEHICLE #1	VEHICLE #2
01. MOTORHOME 02. RV	01. MOTORHOME 02. RV
03. AIRPLN 04. BOAT	03. AIRPLN 04. BOAT
97. OTHER: _____	97. OTHER: _____

G27. About how much is this (TYPE OF VEHICLE) worth?

\$ _____	\$ _____
----------	----------

G28. Not counting any loans that I have already recorded, is any money still owed on loans for this (TYPE OF VEHICLE)?

1. YES 5. NO	1. YES 5. NO
↓	↓
GO BACK TO G26 FOR VEH #2 OR TURN TO P. 44, SECTION H	NEXT PG, G39 COL. 2

G29. In what month and year was this loan taken out?

_____	_____
MONTH/YEAR	MONTH/YEAR

G30. How much was borrowed or financed, not counting the finance charges?

\$ _____	\$ _____
----------	----------

G31. Is this a regular installment loan where you pay a fixed dollar amount each month for a fixed number of months until the loan is repaid, or some other kind?

1. REG. INSTALLMENT 2. OTHER KIND 8. DK	1. REG. INSTALLMENT 2. OTHER KIND 8. DK
↓	↓
NEXT PAGE, G34	NEXT PAGE, G34

G32. How many monthly payments or years were agreed upon when the loan was received?

# PAYMENTS OR # YEARS	# PAYMENTS OR # YEARS
↓	↓
996.NO SET #	996.NO SET #
↓	↓
998.DK	998.DK
↓	↓
NEXT PAGE, G34	NEXT PAGE, G34

NEXT PAGE, G33 COL. 1

NEXT PAGE, G33 COL. 2

G33. How much are the monthly payments?

VEHICLE #1	VEHICLE #2
\$ _____ PER MONTH GO TO G37	\$ _____ PER MONTH GO TO G37
9996. NO REGULAR PAYMENTS	9996. NO REGULAR PAYMENTS

G34. What is the typical payment and how often is it made?

\$ _____ PER _____	\$ _____ PER _____
9996. NO TYPICAL PMT	9996. NO TYPICAL PMT

G35. In what month and year do you expect this loan to be repaid?

_____ MONTH/YEAR	_____ MONTH/YEAR
---------------------	---------------------

G36. How much is still owed on this loan?

\$ _____	\$ _____
----------	----------

G37. What is the current annual rate of interest being charged on the loan?

_____%	_____%
--------	--------

G38. (Please look at Card A.) Is this loan with any of the institutions (you told me about at the beginning of the interview/on Card A), or from someplace else?
(IF CARD A: Which institution?)
(IF SOMEPLACE ELSE: What type of institution is that?)

01. # 1	04. # 4	01. # 1	04. # 4
02. # 2	05. # 5	02. # 2	05. # 5
03. # 3	06. # 6	03. # 3	06. # 6
11. COMMERCIAL BANK		11. COMMERCIAL BANK	
12. S & L/ SAVING BK		12. S & L/ SAVING BK	
13. CREDIT UNION		13. CREDIT UNION	
14. FINANCE; LOAN CO		14. FINANCE; LOAN CO	
97. OTHER: _____		97. OTHER: _____	

G39. INTERVIEWER CHECKPOINT (SEE G25a, P. 41)

<input type="checkbox"/> 1. ONLY 1 VEHICLE TURN TO P. 44, SECTION H	<input type="checkbox"/> 1. ONLY 2 VEHICLES TURN TO P. 44, SECTION H
<input type="checkbox"/> 2. ALL OTHERS --> GO BACK TO P. 41, G26, VEHICLE #2	<input type="checkbox"/> 2. ALL OTHERS NEXT PAGE, G39a

G39a. How much (is/are all) the other such vehicle(s) that you (and others in your family living here) own worth?

\$ _____

DON'T KNOW

G39b. Not counting loans I have already recorded, is any money still owed on loans for (this/these) vehicle(s)?

1. YES

5. NO --->NEXT PAGE, SECTION H



G39c. Altogether, about how much is still owed on (this/these) loan(s)?

\$ _____

G39d. How much are the total monthly payments on (this/these) loan(s)?

\$ _____ PER _____

SECTION H: LOANS

H1. Not counting credit cards or loans you have already told me about, do you (and your family living here) owe any money on loans for:

H2. FOR EACH "YES", ASK:
How many such loans do you have?

- a. ..household appliances, furniture, or hobby or recreational equipment?
- b. ..loans for educational expenses or medical bills?
- c. ..loans from friends or relatives?
- d. ..any other loans? (IF R ASKS: INCLUDE CHECKING ACCOUNT OVERDRAFTS. DO NOT INCLUDE LIFE INS. POLICY LOANS.)

NO YES
(5) (1)

- > a. _____
- > b. _____
- > c. _____
- > d. _____

H3. IWER CHECKPOINT: ADD TOTAL NUMBER OF LOANS FROM H2a - H2d----->

96. NONE OR # OF LOANS

TURN TO P. 46, H16

GO TO H4

LOAN # 1

LOAN # 2

LOAN # 3

H4. What was (this/the largest/the next) loan for?

_____	_____	_____
-------	-------	-------

H5. In what month and year was this loan taken out?

_____/_____ MONTH/YEAR	_____/_____ MONTH/YEAR	_____/_____ MONTH/YEAR
---------------------------	---------------------------	---------------------------

H6. How much was borrowed or financed, not counting the finance charges?

\$ _____	\$ _____	\$ _____
----------	----------	----------

H7. Is this a regular installment loan where you pay a fixed dollar amount each month for a fixed number of months until the loan is repaid, or some other kind?

<div style="display: flex; justify-content: space-around;"> <div style="border: 1px solid black; padding: 5px; text-align: center;">1. REGULAR INSTALL- MENT</div> <div style="border: 1px solid black; padding: 5px; text-align: center;">2. OTHER KIND</div> </div> <div style="margin-top: 10px;"> <div style="border: 1px solid black; padding: 5px; text-align: center;">8. DK</div> </div> <p style="text-align: center;">NEXT PAGE, H10</p>	<div style="display: flex; justify-content: space-around;"> <div style="border: 1px solid black; padding: 5px; text-align: center;">1. REGULAR INSTALL- MENT</div> <div style="border: 1px solid black; padding: 5px; text-align: center;">2. OTHER KIND</div> </div> <div style="margin-top: 10px;"> <div style="border: 1px solid black; padding: 5px; text-align: center;">8. DK</div> </div> <p style="text-align: center;">NEXT PAGE, H10</p>	<div style="display: flex; justify-content: space-around;"> <div style="border: 1px solid black; padding: 5px; text-align: center;">1. REGULAR INSTALL- MENT</div> <div style="border: 1px solid black; padding: 5px; text-align: center;">2. OTHER KIND</div> </div> <div style="margin-top: 10px;"> <div style="border: 1px solid black; padding: 5px; text-align: center;">8. DK</div> </div> <p style="text-align: center;">NEXT PAGE, H10</p>
--	--	--

H8. How many monthly payments or years were agreed upon when the loan was received?

# PAYMENTS OR # YEARS	# PAYMENTS OR # YEARS	# PAYMENTS OR # YEARS
<div style="border: 1px solid black; padding: 5px; width: 80%; margin: 0 auto;">996. NO SET #</div> <div style="display: flex; justify-content: space-between; margin-top: 5px;"> <div style="text-align: center;">NEXT PAGE, H9</div> <div style="border: 1px solid black; padding: 5px; text-align: center;">998. DK</div> </div> <p style="text-align: center;">NEXT PAGE, H10</p>	<div style="border: 1px solid black; padding: 5px; width: 80%; margin: 0 auto;">996. NO SET #</div> <div style="display: flex; justify-content: space-between; margin-top: 5px;"> <div style="text-align: center;">NEXT PAGE, H9</div> <div style="border: 1px solid black; padding: 5px; text-align: center;">998. DK</div> </div> <p style="text-align: center;">NEXT PAGE, H10</p>	<div style="border: 1px solid black; padding: 5px; width: 80%; margin: 0 auto;">996. NO SET #</div> <div style="display: flex; justify-content: space-between; margin-top: 5px;"> <div style="text-align: center;">NEXT PAGE, H9</div> <div style="border: 1px solid black; padding: 5px; text-align: center;">998. DK</div> </div> <p style="text-align: center;">NEXT PAGE, H10</p>

	LOAN # 1	LOAN # 2	LOAN # 3
H9. How much are the monthly payments?	\$ _____ PER MONTH GO TO H13	\$ _____ PER MONTH GO TO H13	\$ _____ PER MONTH GO TO H13
	NO REGULAR PYMNTS ↓	NO REGULAR PYMNTS ↓	NO REGULAR PYMNTS ↓
H10. What is the typical payment and how often is it made?	\$ _____ PER _____ 9996. NO TYPICAL PAYMENT	\$ _____ PER _____ 9996. NO TYPICAL PAYMENT	\$ _____ PER _____ 9996. NO TYPICAL PAYMENT
H11. In what month and year do you expect this loan to be repaid?	_____/_____/_____ 998. DK	_____/_____/_____ 998. DK	_____/_____/_____ 998. DK
H12. How much is still owed on this loan?	\$ _____	\$ _____	\$ _____
H13. What is the current annual rate of interest being charged on this loan?	_____ %	_____ %	_____ %
H14. (Please look at Card A.) Is this loan with any of the institutions (you told me about at the beginning of the interview/on Card A), or from someplace else? (IF CARD A: Which institution?) (IF SOMEPLACE ELSE: What type of institution is that?)	01. #1 04. #4	01. #1 04. #4	01. #1 04. #4
	02. #2 05. #5	02. #2 05. #5	02. #2 05. #5
	03. #3 06. #6	03. #3 06. #6	03. #3 06. #6
	11. COMM BANK	11. COMM BANK	11. COMM BANK
	12. S&L/SAVNGS BANK	12. S&L/SAVNGS BANK	12. S&L/SAVNGS BANK
	13. CREDIT UNION	13. CREDIT UNION	13. CREDIT UNION
	14. FIN/LOAN CO	14. FIN/LOAN CO	14. FIN/LOAN CO
	15. STORE/DEALER	15. STORE/DEALER	15. STORE/DEALER
	97. OTHER: _____	97. OTHER: _____	97. OTHER: _____
		_____	_____
H15. INTERVIEWER CHECKPOINT (SEE H3, P. 44)	<input type="checkbox"/> 1. ONLY 1 LOAN TURN TO P. 46, H16	<input type="checkbox"/> 1. ONLY 2 LOANS TURN TO P. 46, H16	<input type="checkbox"/> 1. ONLY 3 LOANS TURN TO P. 46, H16
	<input type="checkbox"/> 2. ALL OTHERS->GO BACK TO P. 44, H4, COL. 2	<input type="checkbox"/> 2. ALL OTHERS->GO BACK TO P. 44, H4, COL. 3	<input type="checkbox"/> 2. ALL OTHERS->GO TO EXTRA LOAN NEXT PAGE, H4

EXTRA LOAN PAGE

	LOAN # 4	LOAN # 5	LOAN # 6
H4. What was the next loan for?	_____ _____	_____ _____	_____ _____
H5. In what month and year was this loan taken out?	____/____ MONTH/YEAR	____/____ MONTH/YEAR	____/____ MONTH/YEAR
H6. How much was borrowed or financed, <u>not</u> counting the finance charges?	\$ _____	\$ _____	\$ _____
H7. Is this a regular installment loan where you pay a fixed dollar amount each month for a fixed number of months until the loan is repaid, or some other kind?	<div style="display: flex; justify-content: space-around;"> <div style="border: 1px solid black; padding: 5px; text-align: center;">1. REGULAR INSTALL- MENT</div> <div style="border: 1px solid black; padding: 5px; text-align: center;">2. OTHER KIND</div> </div> <div style="margin-top: 10px; text-align: center;"> <div style="border: 1px solid black; padding: 5px; text-align: center;">8. DK</div> </div> <p style="text-align: center;">NEXT PAGE, H10</p>	<div style="display: flex; justify-content: space-around;"> <div style="border: 1px solid black; padding: 5px; text-align: center;">1. REGULAR INSTALL- MENT</div> <div style="border: 1px solid black; padding: 5px; text-align: center;">2. OTHER KIND</div> </div> <div style="margin-top: 10px; text-align: center;"> <div style="border: 1px solid black; padding: 5px; text-align: center;">8. DK</div> </div> <p style="text-align: center;">NEXT PAGE, H10</p>	<div style="display: flex; justify-content: space-around;"> <div style="border: 1px solid black; padding: 5px; text-align: center;">1. REGULAR INSTALL- MENT</div> <div style="border: 1px solid black; padding: 5px; text-align: center;">2. OTHER KIND</div> </div> <div style="margin-top: 10px; text-align: center;"> <div style="border: 1px solid black; padding: 5px; text-align: center;">8. DK</div> </div> <p style="text-align: center;">NEXT PAGE, H10</p>
H8. How many monthly payments or years were agreed upon when the loan was received?	<p style="text-align: center;"># PAYMENTS OR # YEARS</p> <div style="display: flex; justify-content: space-around;"> <div style="border: 1px solid black; padding: 5px; text-align: center;">NEXT PAGE, H9</div> <div style="border: 1px solid black; padding: 5px; text-align: center;">996. NO SET #</div> </div> <div style="margin-top: 10px; text-align: center;"> <div style="border: 1px solid black; padding: 5px; text-align: center;">998. DK</div> </div> <p style="text-align: center;">NEXT PAGE, H10</p>	<p style="text-align: center;"># PAYMENTS OR # YEARS</p> <div style="display: flex; justify-content: space-around;"> <div style="border: 1px solid black; padding: 5px; text-align: center;">NEXT PAGE, H9</div> <div style="border: 1px solid black; padding: 5px; text-align: center;">996. NO SET #</div> </div> <div style="margin-top: 10px; text-align: center;"> <div style="border: 1px solid black; padding: 5px; text-align: center;">998. DK</div> </div> <p style="text-align: center;">NEXT PAGE, H10</p>	<p style="text-align: center;"># PAYMENTS OR # YEARS</p> <div style="display: flex; justify-content: space-around;"> <div style="border: 1px solid black; padding: 5px; text-align: center;">NEXT PAGE, H9</div> <div style="border: 1px solid black; padding: 5px; text-align: center;">996. NO SET #</div> </div> <div style="margin-top: 10px; text-align: center;"> <div style="border: 1px solid black; padding: 5px; text-align: center;">998. DK</div> </div> <p style="text-align: center;">NEXT PAGE, H10</p>

EXTRA LOAN PAGE

	LOAN # 4	LOAN # 5	LOAN # 6			
H9. How much are the monthly payments?	\$ _____ PER MONTH GO TO H13	\$ _____ PER MONTH GO TO H13	\$ _____ PER MONTH GO TO H13			
	NO REGULAR PYMNTS	NO REGULAR PYMNTS	NO REGULAR PYMNTS			
H10. What is the typical payment and how often is it made?	\$ _____ PER _____ 9996. NO TYPICAL PAYMENT	\$ _____ PER _____ 9996. NO TYPICAL PAYMENT	\$ _____ PER _____ 9996. NO TYPICAL PAYMENT			
H11. In what month and year do you expect this loan to be repaid?	_____/_____/_____ 998. DK	_____/_____/_____ 998. DK	_____/_____/_____ 998. DK			
H12. How much is still owed on this loan?	\$ _____	\$ _____	\$ _____			
H13. What is the current annual rate of interest being charged on this loan?	_____%	_____%	_____%			
H14. (Please look at Card A.) Is this loan with any of the institutions (you told me about at the beginning of the interview/on Card A), or from someplace else? (IF CARD A: Which institution?) (IF SOMEPLACE ELSE: What type of institution?)	01. #1	04. #4	01. #1	04. #4	01. #1	04. #4
	02. #2	05. #5	02. #2	05. #5	02. #2	05. #5
	03. #3	06. #6	03. #3	06. #6	03. #3	06. #6
	11. COMM BANK		11. COMM BANK		11. COMM BANK	
	12. S&L/SAVNGS BANK		12. S&L/SAVNGS BANK		12. S&L/SAVNGS BANK	
	13. CREDIT UNION		13. CREDIT UNION		13. CREDIT UNION	
	14. FIN/LOAN CO		14. FIN/LOAN CO		14. FIN/LOAN CO	
	15. STORE/DEALER		15. STORE/DEALER		15. STORE/DEALER	
	97. OTHER: _____		97. OTHER: _____		97. OTHER: _____	
	97. OTHER: _____		97. OTHER: _____		97. OTHER: _____	
H15. INTERVIEWER CHECKPOINT (SEE H3, P. 44)	<input type="checkbox"/> 1. ONLY 4 LOANS NEXT PAGE, H16	<input type="checkbox"/> 1. ONLY 5 LOANS NEXT PAGE, H16	NEXT PAGE, H16			
	<input type="checkbox"/> 2. ALL OTHERS->GO BACK TO H4, LOAN 5	<input type="checkbox"/> 2. ALL OTHERS->GO BACK TO H4, LOAN 6				

H16. INTERVIEWER CHECKPOINT

<input type="checkbox"/>	1. R HAS ANY TYPE OF LOAN OR DEBT -- MORTGAGE, HOUSING LOAN, PROPERTY, VEHICLE OR OTHER LOANS
<input type="checkbox"/>	2. ALL OTHERS --->NEXT PAGE, SECTION J



H17. Thinking about the loan or mortgage that you took out most recently, what was the main reason you chose the lender that you did? Was it because of the location of their offices, because they had the best interest rates, because you were able to obtain many services at one place, because they were recommended by someone else, or some other reason?

03. LOCATION OF OFFICES	02. INTEREST RATES	06. MANY SERVICES IN ONE PLACE
01. RECOMMENDED	97. OTHER: _____ _____	

H18. (READ SLOWLY:) Again thinking about the same loan, roughly how far was the office where the application was made from the home or workplace of the person who made the application? (IF R ASKS: WE WANT THE CLOSER OF THE DISTANCE FROM HOME OR OFFICE.) (ACCEPT RANGE.)

_____ MILES

96. LESS THAN A MILE	51. OVER 50 MILES	98. DK
----------------------	-------------------	--------

H19. Now thinking of all the various loan payments you made during the last year, were all the payments made the way they were scheduled, or were payments on any of the loans sometimes made later or missed?

1. ALL PAID AS SCHEDULED	5. SOMETIMES GOT BEHIND OR MISSED PAYMENTS
--------------------------	--

NEXT PAGE, SECTION J



H19a. Were you ever behind in your payments by two months or more?

1. YES	5. NO
--------	-------

SECTION J: SAVINGS ATTITUDES

J1. Now I'd like to ask a few questions about your (family's) savings. People have different reasons for saving. What are your (family's) most important reasons for saving? (DO NOT PROBE "AO".)

J2. In deciding how much of their (family) income to spend or save, people are likely to think about different financial planning periods. In planning your (family's) saving and spending, what time period is most important to you (and your [husband/wife])? Would you say the next few months, the next year, the next few years, the next 5-10 years, or longer than 10 years?

	J2. MOST IMPORTANT	J3. LEAST IMPORTANT
1. NEXT FEW MONTHS		
2. NEXT YEAR		
3. NEXT FEW YEARS		
4. NEXT 5 - 10 YEARS		
5. LONGER THAN 10 YEARS		

J3. Which is the least important to you? (RECORD ANSWER IN GRID ABOVE.)

J4. Are there any foreseeable major financial obligations that you (and your family) expect will have to be met in the future, such as educational expenses, health care costs, and so forth? (IF R ASKS, THE FUTURE MEANS THE NEXT FIVE TO TEN YEARS.)

1. YES 5. NO ----->NEXT PAGE, J5

J4a. What kinds of obligations are these? (CHECK ALL THAT APPLY.)

01. EDUCATION: R'S CHILDREN	02. EDUCATION: OTHERS	03. HEALTH CARE: SELF/SPOUSE	04. HEALTH CARE: OTHERS
--------------------------------	--------------------------	---------------------------------	----------------------------

97. OTHER: _____

J5. Which of the following statements comes closest to the amount of financial risk that you (and your [husband/wife]) are willing to take when you save or make investments? (IWER: READ OPTIONS.)

- 1. TAKE SUBSTANTIAL FINANCIAL RISKS EXPECTING TO EARN SUBSTANTIAL RETURNS.
- 2. TAKE ABOVE AVERAGE FINANCIAL RISKS EXPECTING TO EARN ABOVE AVERAGE RETURNS.
- 3. TAKE AVERAGE FINANCIAL RISKS EXPECTING TO EARN AVERAGE RETURNS.
- 4. NOT WILLING TO TAKE ANY FINANCIAL RISKS.

J6. Some families don't spend all their income and do some saving, some spend more than their income and dip into their past savings, while others spend just about as much as they take in. Which is true for you (and your husband/wife) -- don't spend all your income, spend more than income, or spend about as much as income?

- | | | |
|---------------------------|---------------------------|----------------------------------|
| 1. DON'T SPEND ALL INCOME | 2. SPEND MORE THAN INCOME | 3. SPEND ABOUT AS MUCH AS INCOME |
|---------------------------|---------------------------|----------------------------------|

NEXT PAGE, J7

J6a. Please tell me which of the following statements describes your (and your [husband's/wife's]) saving habits? Do you...

	YES (1)	NO (5)
1. SAVE WHATEVER IS LEFT OVER AT THE END OF THE MONTHS -- NO REGULAR PLAN		
2. SAVE INCOME OF ONE FAMILY MEMBER, SPEND THE OTHER		
3. SPEND REGULAR INCOME, SAVE OTHER INCOME		
4. SAVE REGULARLY BY PUTTING MONEY ASIDE EACH MONTH		

SECTION M: BUSINESSES

M1. INTERVIEWER CHECKPOINT

SEE D3, PAGE 10

1. R OR R'S FAMILY OPERATE FARM/RANCH BUSINESS ON THEIR PROPERTY (R ANSWERED "YES" TO D3)

2. ALL OTHERS -->GO TO M3

M2. Including your (farm/ranch) business here, in how many (farms/ranches), privately-held businesses, professional practices or partnerships do you (or your family living here) own or share ownership in and have an active management role?
(INCLUDE THE GENERAL PARTNERS IN A LIMITED PARTNERSHIP, BUT NOT THE LIMITED PARTNERS.)

_____ # BUSINESSES

DO NOT INCLUDE CORPORATIONS WITH PUBLICLY-TRADED STOCK OR ANY PROPERTY PARTNERSHIPS THAT HAVE ALREADY BEEN RECORDED IN SECTION E.

M2a. READ THE FOLLOWING: I will ask you first about your (farm/ranch) business.

RECORD # OF BUSINESSES (FROM M2) IN BOX M5 AT TOP OF NEXT PAGE, THEN GO TO M5a

M3. Do you (and your family living here) own or share ownership in any privately-held businesses, farms, professional practices or partnerships?
(SEE INSTRUCTION IN BOX ABOVE.)

1. YES 5. NO -->TURN TO P. 59, SECTION N

M4. Do you (or anyone in your family living here) have an active management role in any of these businesses?
(INCLUDE THE GENERAL PARTNERS IN A LIMITED PARTNERSHIP, BUT NOT THE LIMITED PARTNERS.)

1. YES 5. NO -->TURN TO P. 55, M20a

M4a. In how many businesses do you (or anyone in your family living here) have an active management role?

_____ # BUSINESSES

ENTER # OF BUSINESSES AT M5 ON TOP OF NEXT PAGE

M5. # OF BUSINESSES

	BUSINESS # 1	BUSINESS # 2	BUSINESS # 3
M5a. What kind of business is (it/ the largest business/the next business) -- that is, what does the business make or do?	<hr/> <hr/> <hr/> <hr/> <hr/>	<hr/> <hr/> <hr/> <hr/> <hr/>	<hr/> <hr/> <hr/> <hr/> <hr/>
M6. How did you (or your family living here) acquire this business; was it bought or invested in, started by you, inherited, given to you, or what?	<div style="border: 1px solid black; padding: 2px; margin-bottom: 2px;">1. BOUGHT/INVEST</div> <div style="border: 1px solid black; padding: 2px; margin-bottom: 2px;">2. STARTED</div> <div style="border: 1px solid black; padding: 2px; margin-bottom: 2px;">3. INHERITED</div> <div style="border: 1px solid black; padding: 2px; margin-bottom: 2px;">4. GIVEN</div> <div style="border: 1px solid black; padding: 2px; margin-bottom: 2px;">7. OTHER: _____</div> <div style="border: 1px solid black; padding: 2px; margin-bottom: 2px;"> </div> <div style="border: 1px solid black; padding: 2px; margin-bottom: 2px;"> </div> <div style="text-align: center;">GO TO M8</div>	<div style="border: 1px solid black; padding: 2px; margin-bottom: 2px;">1. BOUGHT/INVEST</div> <div style="border: 1px solid black; padding: 2px; margin-bottom: 2px;">2. STARTED</div> <div style="border: 1px solid black; padding: 2px; margin-bottom: 2px;">3. INHERITED</div> <div style="border: 1px solid black; padding: 2px; margin-bottom: 2px;">4. GIVEN</div> <div style="border: 1px solid black; padding: 2px; margin-bottom: 2px;">7. OTHER: _____</div> <div style="border: 1px solid black; padding: 2px; margin-bottom: 2px;"> </div> <div style="border: 1px solid black; padding: 2px; margin-bottom: 2px;"> </div> <div style="text-align: center;">GO TO M8</div>	<div style="border: 1px solid black; padding: 2px; margin-bottom: 2px;">1. BOUGHT/INVEST</div> <div style="border: 1px solid black; padding: 2px; margin-bottom: 2px;">2. STARTED</div> <div style="border: 1px solid black; padding: 2px; margin-bottom: 2px;">3. INHERITED</div> <div style="border: 1px solid black; padding: 2px; margin-bottom: 2px;">4. GIVEN</div> <div style="border: 1px solid black; padding: 2px; margin-bottom: 2px;">7. OTHER: _____</div> <div style="border: 1px solid black; padding: 2px; margin-bottom: 2px;"> </div> <div style="border: 1px solid black; padding: 2px; margin-bottom: 2px;"> </div> <div style="text-align: center;">GO TO M8</div>
M7. When you invested did you (or anyone in your family living here) intend to make day-to-day decisions and work at least 5 hours per week in the business?	<div style="border: 1px solid black; padding: 2px; display: inline-block; margin-right: 10px;">1. YES</div> <div style="border: 1px solid black; padding: 2px; display: inline-block;">5. NO</div>	<div style="border: 1px solid black; padding: 2px; display: inline-block; margin-right: 10px;">1. YES</div> <div style="border: 1px solid black; padding: 2px; display: inline-block;">5. NO</div>	<div style="border: 1px solid black; padding: 2px; display: inline-block; margin-right: 10px;">1. YES</div> <div style="border: 1px solid black; padding: 2px; display: inline-block;">5. NO</div>
M8. In what year did you (start/ acquire) the business?	<hr style="width: 80%; margin: 0 auto;"/> <p>YEAR</p>	<hr style="width: 80%; margin: 0 auto;"/> <p>YEAR</p>	<hr style="width: 80%; margin: 0 auto;"/> <p>YEAR</p>
M9. How many employees does it have including you (and members of your family)?	<hr style="width: 80%; margin: 0 auto;"/> <p># EMPL.</p>	<hr style="width: 80%; margin: 0 auto;"/> <p># EMPL.</p>	<hr style="width: 80%; margin: 0 auto;"/> <p># EMPL.</p>

NEXT PAGE, M9a, COLUMN 1

NEXT PAGE, M9a, COLUMN 2

NEXT PAGE, M9a, COLUMN 3

M9a. INTERVIEWER CHECKPOINT: (SEE HHL UPDATE, ITEM #9a)

M9b. Which members of your family living here work in the business? (CHECK ALL THAT APPLY.)

M9c. (Other than you [and your husband/wife]), how many hours does the (other/most involved) family member work in this business in a normal week?

M9d. Is it a partnership, a sole proprietorship, a subchapter S corporation, another type of corporation, or what?

BUSINESS # 1	BUSINESS # 2	BUSINESS # 3
<input type="checkbox"/> 1. R LIVES ALONE GO TO M9d <input type="checkbox"/> 2. ALL OTHERS ↓	<input type="checkbox"/> 1. R LIVES ALONE GO TO M9d <input type="checkbox"/> 2. ALL OTHERS ↓	<input type="checkbox"/> 1. R LIVES ALONE GO TO M9d <input type="checkbox"/> 2. ALL OTHERS ↓
<input type="checkbox"/> A. R <input type="checkbox"/> B. SPOUSE IF <u>ONLY</u> R OR SP CHECKED, GO TO M9d <input type="checkbox"/> C. ADULT CHILD <input type="checkbox"/> D. OTHER ADULT IN HH <input type="checkbox"/> E: OTHER: _____ _____	<input type="checkbox"/> A. R <input type="checkbox"/> B. SPOUSE IF <u>ONLY</u> R OR SP CHECKED, GO TO M9d <input type="checkbox"/> C. ADULT CHILD <input type="checkbox"/> D. OTHER ADULT IN HH <input type="checkbox"/> E: OTHER: _____ _____	<input type="checkbox"/> A. R <input type="checkbox"/> B. SPOUSE IF <u>ONLY</u> R OR SP CHECKED, GO TO M9d <input type="checkbox"/> C. ADULT CHILD <input type="checkbox"/> D. OTHER ADULT IN HH <input type="checkbox"/> E: OTHER: _____ _____
_____ HRS	_____ HRS	_____ HRS
1. PARTNERSHIP	1. PARTNERSHIP	1. PARTNERSHIP
2. SOLE PROPRIET.	2. SOLE PROPRIET.	2. SOLE PROPRIET.
3. SUBCHAP. S	3. SUBCHAP. S	3. SUBCHAP. S
4. OTHER CORP.	4. OTHER CORP.	4. OTHER CORP.
7. OTHER	7. OTHER	7. OTHER

NEXT PAGE, M10
COLUMN 2

NEXT PAGE, M10,
COLUMN 3

READ ONCE, FIRST TIME THROUGH GRID: These next few questions are about the relation between your (family's) personal finances and the finances of your (family's) business.

NEXT PAGE, M10, COLUMN 1

	BUSINESS # 1	BUSINESS # 2	BUSINESS # 3
M10. Are you (or your family living here) using <u>personal</u> assets as collateral or did you have to cosign or guarantee any loans for this business?	<div style="border: 1px solid black; padding: 2px; width: fit-content; margin-bottom: 5px;">1. YES</div> <div style="border: 1px solid black; padding: 2px; width: fit-content; margin-left: 100px; margin-bottom: 5px;">5. NO</div> <p style="text-align: center;">GO TO M11</p>	<div style="border: 1px solid black; padding: 2px; width: fit-content; margin-bottom: 5px;">1. YES</div> <div style="border: 1px solid black; padding: 2px; width: fit-content; margin-left: 100px; margin-bottom: 5px;">5. NO</div> <p style="text-align: center;">GO TO M11</p>	<div style="border: 1px solid black; padding: 2px; width: fit-content; margin-bottom: 5px;">1. YES</div> <div style="border: 1px solid black; padding: 2px; width: fit-content; margin-left: 100px; margin-bottom: 5px;">5. NO</div> <p style="text-align: center;">GO TO M11</p>
M10a. How much is guaranteed or collateralized?	\$ _____	\$ _____	\$ _____
M10b. Did I record this earlier?	<div style="border: 1px solid black; padding: 2px; width: fit-content; margin-right: 10px;">1. YES</div> <div style="border: 1px solid black; padding: 2px; width: fit-content;">5. NO</div>	<div style="border: 1px solid black; padding: 2px; width: fit-content; margin-right: 10px;">1. YES</div> <div style="border: 1px solid black; padding: 2px; width: fit-content;">5. NO</div>	<div style="border: 1px solid black; padding: 2px; width: fit-content; margin-right: 10px;">1. YES</div> <div style="border: 1px solid black; padding: 2px; width: fit-content;">5. NO</div>
M11. (Other than guarantees,) does the business owe you (or your family living here) any money?	<div style="border: 1px solid black; padding: 2px; width: fit-content; margin-bottom: 5px;">1. YES</div> <div style="border: 1px solid black; padding: 2px; width: fit-content; margin-left: 100px; margin-bottom: 5px;">5. NO</div> <p style="text-align: center;">GO TO M12</p>	<div style="border: 1px solid black; padding: 2px; width: fit-content; margin-bottom: 5px;">1. YES</div> <div style="border: 1px solid black; padding: 2px; width: fit-content; margin-left: 100px; margin-bottom: 5px;">5. NO</div> <p style="text-align: center;">GO TO M12</p>	<div style="border: 1px solid black; padding: 2px; width: fit-content; margin-bottom: 5px;">1. YES</div> <div style="border: 1px solid black; padding: 2px; width: fit-content; margin-left: 100px; margin-bottom: 5px;">5. NO</div> <p style="text-align: center;">GO TO M12</p>
M11a. How much is owed?	\$ _____	\$ _____	\$ _____
M12. Do you (or your family living here) <u>owe the business</u> any money?	<div style="border: 1px solid black; padding: 2px; width: fit-content; margin-bottom: 5px;">1. YES</div> <div style="border: 1px solid black; padding: 2px; width: fit-content; margin-left: 100px; margin-bottom: 5px;">5. NO</div> <p style="text-align: center;">NEXT PAGE, M13</p>	<div style="border: 1px solid black; padding: 2px; width: fit-content; margin-bottom: 5px;">1. YES</div> <div style="border: 1px solid black; padding: 2px; width: fit-content; margin-left: 100px; margin-bottom: 5px;">5. NO</div> <p style="text-align: center;">NEXT PAGE, M13</p>	<div style="border: 1px solid black; padding: 2px; width: fit-content; margin-bottom: 5px;">1. YES</div> <div style="border: 1px solid black; padding: 2px; width: fit-content; margin-left: 100px; margin-bottom: 5px;">5. NO</div> <p style="text-align: center;">NEXT PAGE, M13</p>
M12a. How much do you owe?	\$ _____	\$ _____	\$ _____
M12b. Did I record this earlier?	<div style="border: 1px solid black; padding: 2px; width: fit-content; margin-right: 10px;">1. YES</div> <div style="border: 1px solid black; padding: 2px; width: fit-content;">5. NO</div>	<div style="border: 1px solid black; padding: 2px; width: fit-content; margin-right: 10px;">1. YES</div> <div style="border: 1px solid black; padding: 2px; width: fit-content;">5. NO</div>	<div style="border: 1px solid black; padding: 2px; width: fit-content; margin-right: 10px;">1. YES</div> <div style="border: 1px solid black; padding: 2px; width: fit-content;">5. NO</div>
	NEXT PAGE, M13 COL 1	NEXT PAGE, M13 COL 2	NEXT PAGE, M13 COL 3

	BUSINESS # 1	BUSINESS # 2	BUSINESS # 3
M13. What percentage of the business do you (and your family living here) own?	<input type="text" value="100. ALL"/> _____ PERCENT	<input type="text" value="100. ALL"/> _____ PERCENT	<input type="text" value="100. ALL"/> _____ PERCENT
M14. What could you sell it for? (What is your share worth?)	\$ _____ <input type="text" value="NOTHING"/> <input type="text" value="DON'T KNOW"/>	\$ _____ <input type="text" value="NOTHING"/> <input type="text" value="DON'T KNOW"/>	\$ _____ <input type="text" value="NOTHING"/> <input type="text" value="DON'T KNOW"/>
M15. If you sold the business now, what would be the cost basis for tax purposes of this share? (What was your original investment?)	\$ _____ <input type="text" value="NOTHING"/>	\$ _____ <input type="text" value="NOTHING"/>	\$ _____ <input type="text" value="NOTHING"/>
M16. What were the <u>gross receipts</u> or <u>gross sales</u> of the business as a whole in 1988?	\$ _____	\$ _____	\$ _____
M17. What was the business's total net income before taxes in 1988?	\$ _____	\$ _____	\$ _____
M18. What is the <u>total</u> book value of all owners' or shareholders' equity in this business?	\$ _____	\$ _____	\$ _____
M19. INTERVIEWER CHECKPOINT (SEE M5, P. 51)	<input type="checkbox"/> 1. ONLY 1 BUS. NEXT PAGE, M20 <input type="checkbox"/> 2. ALL OTHERS GO BACK TO P. 51, M5a BUS. #2	<input type="checkbox"/> 1. ONLY 2 BUS. NEXT PAGE, M20 <input type="checkbox"/> 2. ALL OTHERS GO BACK TO P. 51, M5a BUS. #3	<input type="checkbox"/> 1. ONLY 3 BUS. NEXT PAGE, M20 <input type="checkbox"/> 2. ALL OTHERS NEXT PAGE, M19a

M19a. For the remaining business(es) you (and your family living here) own and actively manage, what could you sell your share for? (What is your share worth?)

\$ _____

M19b. If you sold (these businesses/this business) now, what would be the cost basis for tax purposes of your share? (What was your original investment?)

\$ _____

NOTHING

DON'T KNOW

M19c. What was the total net income you (and your family living here) received from (these businesses/this business) in 1988?

\$ _____

M20. Do you (or anyone in your family living here) own or have an interest in any other businesses or partnerships where you do not have an active management role?

1. YES

5. NO --> TURN TO P. 59, SECTION N

M20a. How many of these (other) businesses or partnerships do you (and your family living here) own or share ownership in?

01. ONE

OR

OTHER: _____
NUMBER

--->NEXT PAGE, M21

M20b. Is it a sole-proprietorship, a limited partnership, another type of partnership, a Subchapter S-corporation, another type of corporation, or what?

2. PROPRIETORSHIP

5. LIMITED PARTNERSHIP

1. PARTNERSHIP

3. SUBCHAPTER S

4. OTHER CORP.

7. OTHER: _____

M20c. What could you sell your (family's) share for? (What is it worth?)

\$ _____

NOTHING

M20d. If you sold this (business/partnership) now, what would be the cost basis for tax purposes? (What was your original investment?)

\$ _____

M20e. What was the total net income you (and your family living here) received from this (business/partnership) in 1988?

\$ _____

----->TURN TO P. 59, SECTION N

M21. (I need to know what type of businesses these are.) Are any of them (TYPE)?
 (IWER: FOR EACH YES, ASK FOLLOW-UP QUESTIONS M22 - M24)

TYPE	M22. What could you sell your (family's) share of all these (TYPE) for? (What is it worth?)	M23. If you sold these (TYPE) now, what would be the cost basis for tax purposes of these shares? (What was your original investment?)	M24. What was the total net income you (and your family living here) received from all such (TYPE) in 1988?
a. Limited Partnerships? <input type="checkbox"/> 5. NO <input type="checkbox"/> 1. YES --->	\$ _____	\$ _____	\$ _____
b. Other Partnerships? <input type="checkbox"/> 5. NO <input type="checkbox"/> 1. YES --->	\$ _____	\$ _____	\$ _____
c. Subchapter S Corporations? <input type="checkbox"/> 5. NO <input type="checkbox"/> 1. YES --->	\$ _____	\$ _____	\$ _____
d. Other Corporations? <input type="checkbox"/> 5. NO <input type="checkbox"/> 1. YES --->	\$ _____	\$ _____	\$ _____
e. Sole Proprietorships? <input type="checkbox"/> 5. NO <input type="checkbox"/> 1. YES --->	\$ _____	\$ _____	\$ _____
f. Any other type? <input type="checkbox"/> 5. NO <input type="checkbox"/> 1. YES --->	\$ _____	\$ _____	\$ _____

NEXT PAGE, SECTION N

NEXT PAGE,
SECTION N

PAGES 57 AND 58 DO NOT APPEAR IN THIS QUESTIONNAIRE

SECTION N: FINANCIAL ASSETS

N1. Now I'd like to ask about different types of assets that you might have. First, do you (or anyone in your family living here) have any checking accounts?

1. YES

5. NO

NEXT PAGE, N3



N2. Have you (or anyone in your family living here) ever had a checking account?

1. YES

5. NO

N2a. What is the most important reason (you don't/your family doesn't) have a checking account? Is it because you don't write enough checks to make it worthwhile, because the minimum balance is too high, because you don't like dealing with banks, because the service charges are too high, because no bank has convenient hours or location, or some other reason?

01. DON'T WRITE ENOUGH CHECKS TO MAKE IT WORTHWHILE

04. SERVICE CHARGES ARE TOO HIGH

02. MINIMUM BALANCE IS TOO HIGH

05. NO BANK HAS CONVENIENT HOURS OR LOCATION

03. DO NOT LIKE DEALING WITH BANKS

97. OTHER: _____

TURN TO P. 62, N10

N3. How many checking accounts do you (and your family living here) have?

(IF R ASKS: INCLUDE MONEY MARKET ACCOUNTS WITH CHECK-WRITING PRIVILEGES ONLY IF THEY ARE AT BANKS, SAVINGS AND LOANS, OR CREDIT UNIONS)

ACCOUNTS

		ACCOUNT #1		ACCOUNT #2		ACCOUNT #3	
N4. (Please look at Card A.) (Thinking about your main checking account, the one used to write most of your checks, / About the next account) is this account with any of the institutions (you told me about at the beginning of the interview/on Card A), or from someplace else? (IF CARD A: Which institution?) (IF SOMEPLACE ELSE: What type of institution is that?)		01. #1	04. #4	01. #1	04. #4	01. #1	04. #4
		02. #2	05. #5	02. #2	05. #5	02. #2	05. #5
		03. #3	06. #6	03. #3	06. #6	03. #3	06. #6
		11. COMM. BANK		11. COMM. BANK		11. COMM. BANK	
		12. S&L/ SAV BANK		12. S&L/ SAV BANK		12. S&L/ SAV BANK	
		13. CREDIT UNION		13. CREDIT UNION		13. CREDIT UNION	
		16. BROKERAGE		16. BROKERAGE		16. BROKERAGE	
		97. OTHER: _____		97. OTHER: _____		97. OTHER: _____	
		_____		_____		_____	
	N5. How much is in this account? (What was the average over the last month?)		\$ _____		\$ _____		\$ _____
N6. Is this a money market-type account?		<input type="checkbox"/> 1. YES	<input type="checkbox"/> 5. NO	<input type="checkbox"/> 1. YES	<input type="checkbox"/> 5. NO	<input type="checkbox"/> 1. YES	<input type="checkbox"/> 5. NO
N7. INTERVIEWER CHECKPOINT (SEE N3)		<input type="checkbox"/> 1. ONLY 1 ACCT TURN TO P. 62, N9 <input type="checkbox"/> 2. ALL OTHERS GO BACK TO N4, ACCT #2		<input type="checkbox"/> 1. ONLY 2 ACCT TURN TO P. 62, N9 <input type="checkbox"/> 2. ALL OTHERS GO BACK TO N4, ACCT #3		<input type="checkbox"/> 1. ONLY 3 ACCT TURN TO P. 62, N9 <input type="checkbox"/> 2. ALL OTHERS GO BACK TO N4, ACCT #4	

ACCOUNT #4		ACCOUNT #5		ACCOUNT #6	
01. #1	04. #4	01. #1	04. #4	01. #1	04. #4
02. #2	05. #5	02. #2	05. #5	02. #2	05. #5
03. #3	06. #6	03. #3	06. #6	03. #3	06. #6
11. COMM. BANK		11. COMM. BANK		11. COMM. BANK	
12. S&L/ SAV BANK		12. S&L/ SAV BANK		12. S&L/ SAV BANK	
13. CREDIT UNION		13. CREDIT UNION		13. CREDIT UNION	
16. BROKERAGE		16. BROKERAGE		16. BROKERAGE	
97. OTHER: _____ _____		97. OTHER: _____ _____		97. OTHER: _____ _____	
\$ _____		\$ _____		\$ _____	
<input type="checkbox"/> 1. YES	<input type="checkbox"/> 5. NO	<input type="checkbox"/> 1. YES	<input type="checkbox"/> 5. NO	<input type="checkbox"/> 1. YES	<input type="checkbox"/> 5. NO
<input type="checkbox"/> 1. <u>ONLY</u> 4 ACCT NEXT PAGE, N9	<input type="checkbox"/> 2. ALL OTHERS GO BACK TO P. 60, N4, ACCT. #5	<input type="checkbox"/> 1. <u>ONLY</u> 5 ACCT NEXT PAGE, N9	<input type="checkbox"/> 2. ALL OTHERS GO BACK TO P. 60, N4 ACCT. #6	<input type="checkbox"/> 1. <u>ONLY</u> 6 ACCT NEXT PAGE, N9	<input type="checkbox"/> 2. ALL OTHERS



N8. How much is in all your (family's) remaining checking accounts? (What was the average over the last month?)

\$ _____

N9. What is the most important reason (you/your family living here) chose the institution that you did for your main checking account? Was it because of the location of their offices, because they had the lowest fees or minimum balance requirement, because you were able to obtain many services at one place, because they offered safety and an absence of risk, or some other reason?

- | | | | |
|-------------------------|--------------|-----------------------------------|------------|
| 03. LOCATION OF OFFICES | 07. LOW FEES | 06. MANY SERVICES
IN ONE PLACE | 08. SAFETY |
|-------------------------|--------------|-----------------------------------|------------|

97. OTHER: _____

N9a. For how many years (have you/has someone in your family living here) done business with this institution?

- _____ YEARS
- | |
|------------------------|
| 96. LESS THAN ONE YEAR |
|------------------------|

N10. Do you (or anyone in your family here) have any Individual Retirement Accounts, that is, IRA or Keogh accounts?

- | | | | |
|--|--------|---|-------|
| <table border="1"><tr><td>1. YES</td></tr></table> | 1. YES | <table border="1"><tr><td>5. NO</td></tr></table> | 5. NO |
| 1. YES | | | |
| 5. NO | | | |

NEXT PAGE, N10a

TURN TO P. 64, N16

N10a. Who has IRA or Keogh accounts?

[CHECK PERSON(S) (RESPONDENT, SPOUSE, OR OTHERS) WHO HAVE ACCOUNT(S). THEN ASK FOLLOW-UP QUESTIONS N11 - N14 FOR EACH PERSON.]

PERSON----->

	RESPONDENT ACCOUNTS		SPOUSE ACCOUNTS		OTHER PERSONS	
N11. How many IRA and Keogh accounts does (PERSON) have?	_____ # ACCTS		_____ # ACCTS		_____ # ACCTS	
N12. About (PERSON'S) accounts (are these/is this an) IRA or Keogh account(s)? (CHECK ALL THAT APPLY.)	<input type="checkbox"/> A. IRA	<input type="checkbox"/> B. KEOGH	<input type="checkbox"/> A. IRA	<input type="checkbox"/> B. KEOGH	<input type="checkbox"/> A. IRA	<input type="checkbox"/> B. KEOGH
N13. (Please look at Card A.) (Is this/Are they) with any of the institutions (you told me about at the beginning of the interview/on Card A), or from someplace else? (CHECK ALL THAT APPLY.) (IF CARD A: Which institution(s)?) (IF SOMEPLACE ELSE: What type(s) of institution(s)?)	<input type="checkbox"/> 01. #1	<input type="checkbox"/> 04. #4	<input type="checkbox"/> 01. #1	<input type="checkbox"/> 04. #4	<input type="checkbox"/> 01. #1	<input type="checkbox"/> 04. #4
	<input type="checkbox"/> 02. #2	<input type="checkbox"/> 05. #5	<input type="checkbox"/> 02. #2	<input type="checkbox"/> 05. #5	<input type="checkbox"/> 02. #2	<input type="checkbox"/> 05. #5
	<input type="checkbox"/> 03. #3	<input type="checkbox"/> 06. #6	<input type="checkbox"/> 03. #3	<input type="checkbox"/> 06. #6	<input type="checkbox"/> 03. #3	<input type="checkbox"/> 06. #6
	<input type="checkbox"/> 11. COMM. BANK		<input type="checkbox"/> 11. COMM. BANK		<input type="checkbox"/> 11. COMM. BANK	
	<input type="checkbox"/> 12. S&L/ SAV BANK		<input type="checkbox"/> 12. S&L/ SAV BANK		<input type="checkbox"/> 12. S&L/ SAV BANK	
	<input type="checkbox"/> 13. CREDIT UNION		<input type="checkbox"/> 13. CREDIT UNION		<input type="checkbox"/> 13. CREDIT UNION	
	<input type="checkbox"/> 16. BROKERAGE		<input type="checkbox"/> 16. BROKERAGE		<input type="checkbox"/> 16. BROKERAGE	
	<input type="checkbox"/> 17. INSUR. CO		<input type="checkbox"/> 17. INSUR. CO		<input type="checkbox"/> 17. INSUR. CO	
	<input type="checkbox"/> 25. EMPLOYER		<input type="checkbox"/> 25. EMPLOYER		<input type="checkbox"/> 25. EMPLOYER	
	<input type="checkbox"/> 97. OTHER: _____		<input type="checkbox"/> 97. OTHER: _____		<input type="checkbox"/> 97. OTHER: _____	
N14. How much in total is in (PERSON'S) account(s)?	\$ _____		\$ _____		\$ _____	

N14a. INTERVIEWER CHECKPOINT
(SEE N10a)

<input type="checkbox"/> 1. SPOUSE OR OTHER ACCT GO BACK TO N11	<input type="checkbox"/> 1. OTHER PERSON ACCT. GO BACK TO N11
<input type="checkbox"/> 2. ALL OTHERS	<input type="checkbox"/> 2. ALL OTHERS

N15. How is the money in (this/all of your [family's]) IRA and Keogh account(s) invested? Is most of it in CDs or other bank accounts, most of it in stocks, most of it in bonds or similar assets, or what?

<input type="checkbox"/> 1. CD'S/BANK ACCOUNTS	<input type="checkbox"/> 2. STOCK	<input type="checkbox"/> 3. BONDS/SIMILAR ASSETS
--	-----------------------------------	--

7. OTHER: _____

8. DK

N16. Not including any accounts I have already recorded, do you (or anyone in your family here) have any money market accounts?

1. YES

5. NO --> NEXT PAGE, N22

N16a. Altogether, how many money market accounts do you (and your family living here) have?

OF MONEY MARKET ACCOUNTS

	ACCOUNT #1		ACCOUNT #2		ACCOUNT #3	
N17. Does the (largest/next) account have check-writing privileges?	<input type="checkbox"/> 1. YES	<input type="checkbox"/> 5. NO	<input type="checkbox"/> 1. YES	<input type="checkbox"/> 5. NO	<input type="checkbox"/> 1. YES	<input type="checkbox"/> 5. NO
N18. Is this a tax-free money market account?	<input type="checkbox"/> 1. YES	<input type="checkbox"/> 5. NO	<input type="checkbox"/> 1. YES	<input type="checkbox"/> 5. NO	<input type="checkbox"/> 1. YES	<input type="checkbox"/> 5. NO
N19. (Please look at Card A.) Is this account with any of the institutions (you told me about at the beginning of the interview/on Card A), or from someplace else? (IF CARD A: Which institution?) (IF SOMEPLACE ELSE: What type of institution is that?)	01. #1	04. #4	01. #1	04. #4	01. #1	04. #4
	02. #2	05. #5	02. #2	05. #5	02. #2	05. #5
	03. #3	06. #6	03. #3	06. #6	03. #3	06. #6
	11. COMM. BANK		11. COMM. BANK		11. COMM. BANK	
	12. S&L/ SAV BANK		12. S&L/ SAV BANK		12. S&L/ SAV BANK	
	13. CREDIT UNION		13. CREDIT UNION		13. CREDIT UNION	
	16. BROKERAGE		16. BROKERAGE		16. BROKERAGE	
	97. OTHER: _____		97. OTHER: _____		97. OTHER: _____	
N20. How much is in this account?	\$ _____		\$ _____		\$ _____	
N21. INTERVIEWER CHECKPOINT (SEE N16a)	<input type="checkbox"/> 1. ONLY 1 ACCT NEXT PAGE, N22		<input type="checkbox"/> 1. ONLY 2 ACCT NEXT PAGE N22		<input type="checkbox"/> 1. ONLY 3 ACCT NEXT PAGE N22	
	<input type="checkbox"/> 2. ALL OTHERS GO BACK TO N17, ACCT 2		<input type="checkbox"/> 2. ALL OTHERS GO BACK TO N17, ACCT 3		<input type="checkbox"/> 2. ALL OTHERS	

N21a. How much is in all your (family's) remaining money market accounts?

\$ _____

- N22. Do you (or anyone in your family here) have any CD's or certificates of deposit at financial institutions? (IF YES, SAY: Please do not include CD's that are part of IRAs or Keoghs.)
 (IF R ASKS: CD'S ARE CERTIFICATES HELD FOR A SET PERIOD OF TIME THAT MUST BE CASHED OR RENEWED AT THE MATURITY DATE.)

1. YES

5. NO --> NEXT PAGE, N23

N22a. Altogether, how many such CD's do you (and your family living here) have?

_____ # CERTIFICATES

N22b. What is the total dollar value of (this/all these) CD's?

\$ _____

N22c. (Please look at Card A.) (Is this/Are these) CD's with any of the institutions (you told about at the beginning of the interview/on Card A), or from someplace else? (CHECK ALL THAT APPLY)
 (IF CARD A: Which institution(s)?)
 (IF SOMEPLACE ELSE: What type(s) of institution(s)?)

01. #1

02. #2

03. #3

04. #4

05. #5

06. #6

11. COMM. BANK

12. S&L/SAV BANK

13. CREDIT UNION

16. BROKERAGE

97. OTHER: _____

N23. Do you (or anyone in your family living here) have any (other) accounts at banks, savings and loan associations, or credit unions? These could be passbook accounts, share accounts, Christmas Club accounts, or any other type of savings account.

1. YES



5. NO --> TURN TO P. 68, N27

N23a. Altogether, how many such accounts do you (and your family living here) have?

ACCOUNTS

N24. (Please look at Card A.) Is the (next) largest account with any of the institutions (you told me about at the beginning of the interview/on Card A), or from someplace else?
(IF CARD A: Which institution?)
(IF SOMEPLACE ELSE: What type of institution is that?)

ACCOUNT #1		ACCOUNT #2		ACCOUNT #3	
01. #1	04. #4	01. #1	04. #4	01. #1	04. #4
02. #2	05. #5	02. #2	05. #5	02. #2	05. #5
03. #3	06. #6	03. #3	06. #6	03. #3	06. #6
11. COMM. BANK		11. COMM. BANK		11. COMM. BANK	
12. S&L/ SAV BANK		12. S&L/ SAV BANK		12. S&L/ SAV BANK	
13. CREDIT UNION		13. CREDIT UNION		13. CREDIT UNION	
16. BROKERAGE		16. BROKERAGE		16. BROKERAGE	
97. OTHER: _____ _____		97. OTHER: _____ _____		97. OTHER: _____ _____	
N25. How much is in this account? \$ _____		\$ _____		\$ _____	
N26. INTERVIEWER CHECKPOINT (SEE N23a)		N26. INTERVIEWER CHECKPOINT (SEE N23a)		N26. INTERVIEWER CHECKPOINT (SEE N23a)	
<input type="checkbox"/> 1. ONLY 1 ACCT TURN TO P. 68, N27		<input type="checkbox"/> 1. ONLY 2 ACCT TURN TO P. 68, N27		<input type="checkbox"/> 1. ONLY 3 ACCT TURN TO P. 68, N27	
<input type="checkbox"/> 2. ALL OTHERS GO BACK TO N24, ACCT 2		<input type="checkbox"/> 2. ALL OTHERS GO BACK TO N24, ACCT 3		<input type="checkbox"/> 2. ALL OTHERS GO BACK TO N24, ACCT 4	

ACCOUNT #4		ACCOUNT #5	
01. #1	04. #4	01. #1	04. #4
02. #2	05. #5	02. #2	05. #5
03. #3	06. #6	03. #3	06. #6
11. COMM. BANK		11. COMM. BANK	
12. S&L/ SAV BANK		12. S&L/ SAV BANK	
13. CREDIT UNION		13. CREDIT UNION	
16. BROKERAGE		16. BROKERAGE	
97. OTHER: _____ _____		97. OTHER: _____ _____	
\$ _____		\$ _____	
<input type="checkbox"/> 1. <u>ONLY</u> 4 ACCT NEXT PAGE, N27 <input type="checkbox"/> 2. ALL OTHERS GO BACK TO N24, ACCT.5		<input type="checkbox"/> 1. <u>ONLY</u> 5 ACCT NEXT PAGE, N27 <input type="checkbox"/> 2. ALL OTHERS 	



N26a. How much is in all your (family's) remaining such accounts?

\$ _____

N27. Do you (or anyone in your family here) have any mutual fund holdings? (IF YES, SAY: Please do not include any pension-type, thrift-saving, 401-K, or IRA/Keogh plans, or accounts I have already recorded.)

1. YES

5. NO --> NEXT PAGE, N31

N27a. In how many different mutual funds (do you/does your family) own shares?

_____ # MUTUAL FUNDS

N28. I need to know what type(s) of mutual fund(s) (this is/these are)? (Is it/Are any of them)...

N29. What is the total market value of all of the (TYPE) that you (and your family living here) have?

- a. Stock Funds 5. NO 1. YES -->a. \$ _____
- b. (Are any of them) Tax-Free Bond Funds. 5. NO 1. YES -->b. \$ _____
- c. (Are any of them) Government or Government backed Bond Funds 5. NO 1. YES -->c. \$ _____
- d. (Are any of them) other Bond Funds 5. NO 1. YES -->d. \$ _____
- e. Combination funds or any other mutual funds (INCLUDE "DK TYPE" HERE) 5. NO 1. YES -->e. \$ _____

N30. Overall has there been a gain or loss in the value of all these mutual fund shares since you (or someone in your family here) obtained them?

1. GAIN

3. NEITHER GAIN NOR LOSS

5. LOSS

8. DON'T KNOW



NEXT PAGE, N31



NEXT PAGE, N31

N30a. How much have they gained in value since they were obtained?

_____ PERCENT

OR

\$ _____ AMOUNT

998. DON'T KNOW

N30b. How much have they lost in value since they were obtained?

_____ PERCENT

OR

\$ _____ AMOUNT

998. DON'T KNOW

N31. Do you (or anyone in your family here) have any U.S. government savings bonds?

(THESE MAY BE CALLED SERIES EE OR HH. THEY CAN BE PURCHASED BY PAYROLL DEDUCTION.)

1. YES

5. NO --> GO TO N32

N31a. What is the total face value of all the savings bonds that you (and your family) have?

\$ _____

N32. Do you (or anyone here) have any other corporate, municipal, government, or other type of bonds or bills? (IF YES, SAY: Please do not include any bonds or bills held in pension accounts or trusts, or in accounts I have already recorded.)

1. YES

5. NO --> NEXT PAGE, N35

N32a. How many different bonds or bills do you (or your family) own?

_____ # BONDS OR BILLS

N33. I need to know what type(s) of bond or bill (this is/these are)? (Is it/Are any of them)...

N34. What is the total face value of all of the (TYPE) that you (and your family living here) have?

a. Mortgage-backed bonds such as those from "Ginnie-Mae", "Fannie-Mae" or "Freddie-Mac" . . .

5. NO

1. YES

-->a. \$ _____

b. U.S. Government bonds or Treasury bills.

5. NO

1. YES

-->b. \$ _____

c. State or municipal bonds, or other taxfree bonds

5. NO

1. YES

-->c. \$ _____

d. corporate or foreign bonds, or any other type of bonds.
(INCLUDE "DK TYPE" HERE)

5. NO

1. YES

-->d. \$ _____

N40. Do you (or anyone in your family here) have a brokerage account for the purchase or sale of stocks and other securities?

1. YES

5. NO --> NEXT PAGE, N41

N40a. (Please look at Card A.) (Is this/Are these) accounts with any of the institutions (you told me about at the beginning of the interview/on Card A), or from someplace else? (CHECK ALL THAT APPLY.)
(IF CARD A: Which institution(s)?)
(IF SOMEPLACE ELSE: What type(s) of institution(s)?)

01. #1

02. #2

03. #3

04. #4

05. #5

06. #6

11. COMM. BANK

12. S&L/SAV BANK

16. BROKERAGE

17. INSUR. CO

97. OTHER: _____

N40b. Over the past year, about how many times did you (or anyone in your family living here) buy or sell stocks or other securities through a broker? (ACCEPT RANGE.)

_____ # TIMES

998. DON'T KNOW

996. NONE

N40c. Not including any accounts you've told me about, do you (or anyone in your family living here) have a "cash" or "call money" account at a stock brokerage?
(IF R ASKS: CASH OR CALL MONEY ACCOUNTS HOLD MONEY RECEIVED FROM THE SALE OF STOCK UNTIL THE MONEY IS REINVESTED.)

1. YES

5. NO --> GO TO N40e

N40d. What is the total dollar value of all the cash or call money accounts that you (and your family living here) have?

\$ _____

N40e. Other than loans you have already told me about, do you (or anyone in your family living here) have any margin loans at a stock brokerage?

1. YES

5. NO --> NEXT PAGE, N41

N40f. Altogether, how much is owed on these margin loans?

\$ _____

N41. Do you (or anyone in your family here) receive income from or have assets in a trust, annuity, or managed investment account that you have not already told me about? (IF YES, SAY: Please do not include pension-type accounts, or any assets that I have already recorded.)

1. YES

5. NO --> NEXT PAGE, N47



N42. What are these; are they legal trusts, annuities, or managed investment accounts? (CHECK ALL THAT APPLY)

A. LEGAL TRUSTS

B. ANNUITIES

C. MANAGED INVESTMENT ACCOUNTS

D. OTHER: _____

N43. Are any of these set up so that you (or your family living here) are legally entitled only to the income and do not have an equity interest?

1. YES

5. NO

8. DON'T KNOW



GO TO N44

N43a. How much income did (you/your family living here) receive from these income-only trusts, annuities, or accounts in 1988?

\$ _____ IN 1988

N43b. Do you (or your family living here) also have annuities, trusts, or managed investment accounts in which you (or your family) have an equity interest?

1. YES

5. NO --> NEXT PAGE, N45

N43c. What is the total dollar amount of your (family's) interest in these accounts?

\$ _____

NEXT PAGE, N45

N44. What is the total dollar value of your (family's) interest in all annuities, trusts, or managed investment accounts?

\$ _____

N45. Who manages your (family's) trusts, annuities, or investment accounts,--is it any of the institutions (you told me about at the beginning of the interview/on Card A), or are they managed by someone else? (CHECK ALL THAT APPLY.)
(IF CARD A: Which institution(s)?)
(IF SOMEPLACE ELSE: What type of institution(s) or who manages them?)

01. #1 02. #2 03. #3 04. #4 05. #5 06. #6

11. COMM. BANK 16. BROKERAGE 17. INSUR. CO

23. LAWYER 24. ACCOUNTANT 26. RELATIVE OR FRIEND

37. RESPONDENT/SPOUSE 97. OTHER: _____

N46. How is the money in these trusts and managed accounts invested? Is most of it in stocks, most of it in bonds or other interest-earning assets, or what?

1. STOCKS 2. BONDS/INTEREST 7. OTHER _____

N47. Do you (or anyone in your family living here) have any life insurance, including individual or group policies?

1. YES 5. NO --> TURN TO P. 75, N51

N48. Are any of these group or individual term insurance policies?
(IF R ASKS: TERM INSURANCE POLICIES HAVE NO VALUE UNLESS THE PERSON DIES. MANY SUCH POLICIES ARE ISSUED THROUGH EMPLOYERS AND UNIONS.)

1. YES 5. NO 8. DON'T KNOW

GO TO N49

N48a. What is the current face value of all the term life policies that you (and your family living here) have?

\$ _____

N49. Do you have any policies that build up a cash value or that you can borrow on?
(IF R ASKS: THESE ARE SOMETIMES CALLED "WHOLE LIFE" OR "STRAIGHT LIFE".)

1. YES 5. NO 8. DON'T KNOW

LIFE INSURANCE THAT BUILDS UP A CASH VALUE

N49a. What is the current face value of all of the policies that build up a cash value that you (and your family living here) have?

\$ _____

N49b. What is the total cash value of these policies?

\$ _____

DON'T KNOW

N49c. Are you (or your family) borrowing against these policies?

1. YES

5. NO --> GO TO N49j

N49d. (ASK ONLY IF AN AMOUNT WAS GIVEN IN N49b.) Is the cash value you just gave me net of any loans you have against the policy or is it the gross cash value?

(IF R ASKS: THE NET VALUE IS THE TOTAL CASH VALUE MINUS ANY LOANS.)

1. NET

2. GROSS

8. DON'T KNOW

N49e. Did I record these loans earlier in the interview?

1. YES

5. NO

GO TO N49j

N49f. How much is currently borrowed? \$ _____

N49g. Typically how often (do you/does your family) make payments on these loans and how large are the payments?

\$ _____ PER _____

9996. NO TYPICAL PAYMENTS

N49h. What is the current annual rate of interest being charged on these loans?

_____ %

N49j. How much in total are the yearly premiums for these policies that build up a cash value?

\$ _____ PER _____

NEXT PAGE N51

N50. What is the current face value of all the (other) life insurance policies that you (and your family living here) own?

\$ _____

N51. We have talked about various types of savings, investments, and loans. Other than what I have already recorded, are you (or anyone in your family living here) owed any money by friends, relatives, businesses, or others?
 (WE DO NOT WANT TO INCLUDE PENSION-TYPE OR EMPLOYER PROFIT-SHARING ACCOUNTS HERE.)

1. YES 5. NO --> GO TO N52

N51a. Altogether, how much are you owed? \$ _____

N52. Do you (or anyone in your family living here) have any other substantial assets that I haven't already recorded -- for example, artwork, precious metals, antiques, future proceeds from a lawsuit or estate, oil and gas leases, futures contracts, royalties, or something else?
 (DO NOT INCLUDE PENSION-TYPE OR EMPLOYER PROFIT-SHARING ACCOUNTS HERE.)

1. YES 5. NO --> GO TO N53

N52a. (About the most valuable of these ..)
 What kind of asset is it?

N52b. What is the total dollar value that you (and your family living here) have in (TYPE)?

N52c. Do you have any other substantial assets?

	ASSET #1	ASSET #2	ASSET #3
N52a.	_____ _____ _____	_____ _____ _____	_____ _____ _____
N52b.	\$ _____	\$ _____	\$ _____
N52c.	<input type="checkbox"/> 1. YES --> GO BACK TO N52a, COL #2 <input type="checkbox"/> 5. NO	<input type="checkbox"/> 1. YES --> GO BACK TO N52a, COL #3 <input type="checkbox"/> 5. NO	↓

N53. Do you (or anyone in your family living here) owe any other money not recorded earlier?

1. YES 5. NO --> NEXT PAGE, SECTION R

N53a. How much is still owed on these loans?

\$ _____

THIS IS A BLANK PAGE

R2. Next are some questions about your current, main job. Do you work for someone else, are you self-employed, or what?

1. SOMEONE
ELSE

2. SELF-
EMPLOYED

IF R SAYS, "I RUN MY OWN BUSINESS"
CHECK "SELF-EMPLOYED".

TURN TO P. 80,
R14

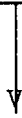

R3. What is the official title of your job? (The title that your employer uses?)

OFFICIAL JOB TITLE

R4. What sort of work do you do on your main job? (Tell me a little more about what you do.)

R5. What kind of business or industry do you work in--that is, what do they make or do at the place where you work?

R6. How many hours do you work on your main job in a normal week?

_____ # HOURS

R7. (READ SLOWLY) Counting paid vacations as weeks of work, how many weeks do you work on this job in a normal year?

_____ # WEEKS

R8. About how much do you earn before taxes on your main job? (Is that per hour, week, month, year, or what?)

\$ _____ PER _____

R9. About how many employees work for this company or organization, including all locations? (Is it fewer than 10, 10 to 19, 20 to 99, 100 to 499, or 500 or more?)

1. LESS THAN 10

2. 10 TO 19

3. 20 TO 99

4. 100 TO 499

5. 500 OR MORE

R10. How many years in total have you worked for this employer?

_____ # YEARS

OR

SINCE _____

R11. How many years do you expect to continue working for this employer? (ACCEPT RANGE.)

_____ # YEARS

OR

UNTIL AGE: _____

96. NEVER
STOP

98. DON'T
KNOW

R12. Are you covered on this job by a union or employee-association contract?

1. YES

5. NO

TURN TO P. 81, R15

R13. NO QUESTION

R SELF-EMPLOYED

R14. What sort of work do you do? (Tell me a little more about what you do.) (IWER: IF R WORKS FOR BUSINESS REPORTED IN SECTION M, MARK BOX.)

R14a. What industry do you work in? That is, what do they do or make? (What industry do you typically work in?)

R14b. How many years have you worked for (yourself/this business)?

_____ # YEARS OR SINCE _____

R14c. About how many years do you expect to continue working for (yourself/this business)? ACCEPT RANGE

_____ # YEARS OR UNTIL AGE: _____

 96. NEVER STOP 98. DON'T KNOW

R14d. How many hours do you work (for yourself/in this business) in a normal week?

_____ # HOURS

R14e. (READ SLOWLY) Counting paid vacations as weeks of work, how many weeks per year do you work on this job?

_____ # WEEKS

R14f. How are you paid? Are you paid a regular salary or wages, do you receive a portion of the net earnings, or what? (CHECK ALL THAT APPLY AND ASK BOTH FOLLOW-UP QUESTIONS IF APPLICABLE.)

 A. SALARY B. WAGES C. NET EARNINGS D. OTHER

R14g. How much in salary or wages are you paid before taxes?
\$ _____ PER _____

R14h. (In addition to regular salary,) how much do you personally earn from the business before taxes? (What did you earn in 1988?)
\$ _____ PER _____

R14j. Are you covered on this job by a union or employee-association contract?

 1. YES 5. NO

R14k. Aside from IRA or Keogh plans, are you included in any pension plans or tax-deferred savings plans through (your work/the business)?

 1. YES 5. NO -->TURN TO P. 90, R40

R15. Many employers have pension or retirement plans, and some provide tax-deferred plans such as thrift, savings, 401K's, profit sharing, or stock ownership plans. Are you included in any pension or retirement plans, or in any tax-deferred savings plans on this job? (DO NOT INCLUDE SOCIAL SECURITY.)

IF R MENTIONS IRA OR KEOGH PLANS, NOTE IN MARGIN AND SAY: "We covered those earlier in the interview. Here, I just want to find out about other plans operated through your employer."

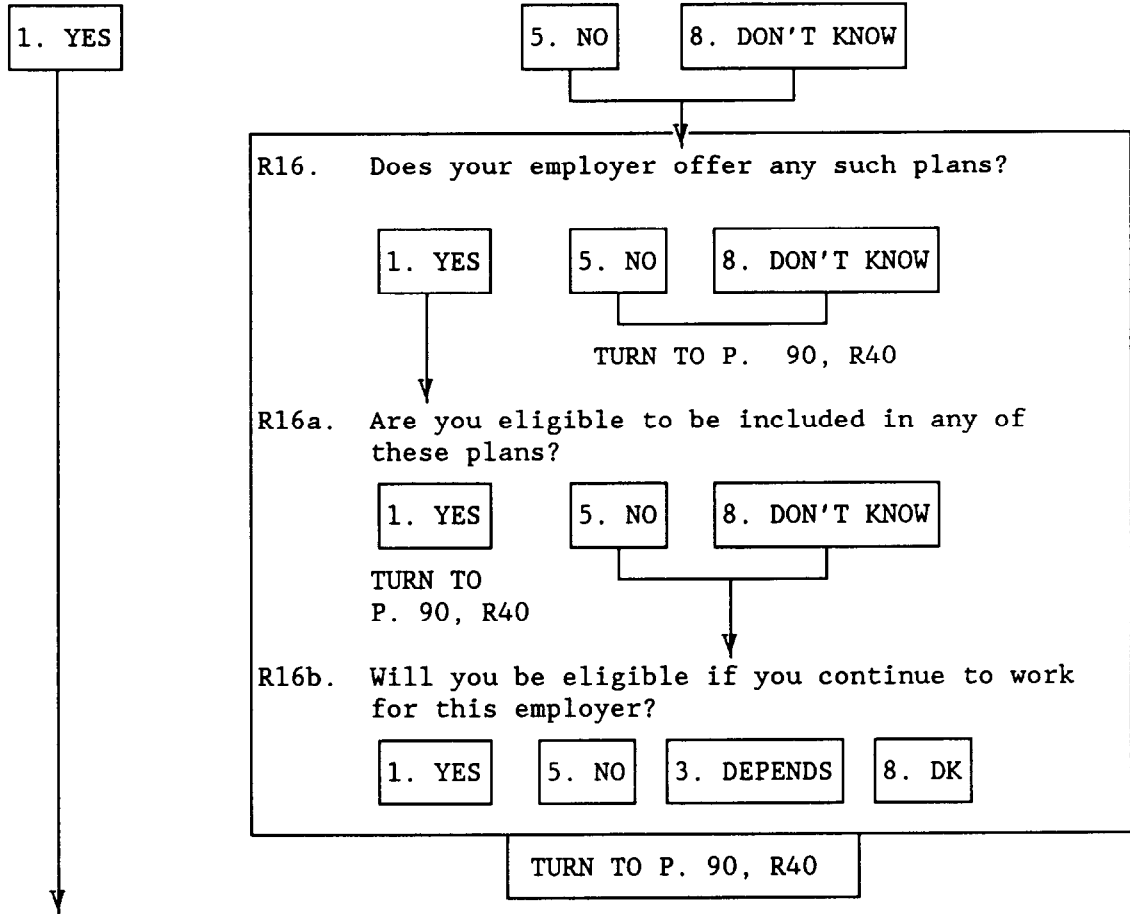

R17. In how many different plans of this sort are you included on this job?

_____ # PLANS

R17a. Are you currently receiving benefit payments from any retirement plans from this job?

1. YES

5. NO

-->RECORD # PLANS (FROM R17) IN BOX AT R18, NEXT PAGE

R17b. I'll ask about the benefits later. Are there any retirement or savings plans from this job where you are not yet drawing benefit payments?

1. YES

5. NO

-->TURN TO P. 90, R40

R17c. How many such plans do you have?

_____ # PLANS--NOT YET RECEIVING BENEFITS

RECORD # PLANS IN BOX AT R18, NEXT PAGE

R18.

OF PLANS

PLAN 1

R19. (Is this/About the (next) most important of these plans, is it) a pension or retirement plan, or a tax-deferred savings plan of some sort?
 (IF R ASKS: 401-K, 403-B, ESOP, SRA, THRIFT/SAVINGS, STOCK/PROFIT SHARING ARE ALL TAX-DEFERRED SAVINGS PLANS.)

1. PENSION OR RETIREMENT -->GO TO R20	
2. TAX-DEFERRED SAVINGS -->TURN TO P. 86, R28, PLAN 1	
7. OTHER	8. DON'T KNOW WHAT KIND

R20. I would like to know what general type of plan this is. In the most common pension or retirement plan, Type A, the amount of the benefit is usually based on a formula involving age, years of service and salary. In other plans, Type B, money is accumulated in an account for you until your retirement. Is your (first/next) plan like Type A or Type B?

1. TYPE A (FORMULA) GO TO R22	2. TYPE B (ACCOUNT) TURN TO P. 86, R28, PLAN 1	3. BOTH A & B	8. DK GO TO R22
----------------------------------	---	---------------	--------------------

R21. For that part of your plan where money is accumulated in an account, how much is in the account?

\$ _____ DON'T KNOW

R22. Do you currently make contributions to this plan?
 (IF R ASKS: INCLUDE CONTRIBUTIONS THROUGH SALARY DEDUCTIONS, UNION DUES OR OTHER SOURCES)

1. YES	5. NO	8. DON'T KNOW
		GO TO R24

R23. What percent of your pay or amount of money per month or year do you currently contribute?

_____ PERCENT OR \$ _____ PER _____

998. DON'T KNOW

R24. At what age do you expect to start receiving benefits from this plan?

AT AGE _____ OR 96. DON'T EXPECT BENEFITS

IN _____ YEARS

TURN TO P. 84, R25--PLAN 1 TURN TO P. 84, R26--PLAN 1

PLAN 2

PLAN 3

R19.	<p>1. PENSION OR RETIREMENT -->GO TO R20 PLAN 2</p> <p>2. TAX-DEFERRED SAVINGS -->TURN TO P. 87, R28, PLAN 2</p> <p>7. OTHER 8. DON'T KNOW WHAT KIND</p>	<p>1. PENSION OR RETIREMENT -->GO TO R20 PLAN 3</p> <p>2. TAX-DEFERRED SAVINGS -->TURN TO P.87, R28, PLAN 3</p> <p>7. OTHER 8. DON'T KNOW WHAT KIND</p>
R20.	<p>1. TYPE A (FORMULA) 2. TYPE B (ACCOUNT) 3. BOTH A & B 8. DK</p> <p>GO TO R22 TURN TO P. 87, R28 PLAN 2 GO TO R22</p>	<p>1. TYPE A (FORMULA) 2. TYPE B (ACCOUNT) 3. BOTH A & B 8. DK</p> <p>GO TO R22 TURN TO P. 87, R28 PLAN 3 GO TO R22</p>
R21.	<p>\$ _____ DON'T KNOW</p>	<p>\$ _____ DON'T KNOW</p>
R22.	<p>1. YES 5. NO 8. DON'T KNOW</p> <p>GO TO R24</p>	<p>1. YES 5. NO 8. DON'T KNOW</p> <p>GO TO R24</p>
R23.	<p>_____ PERCENT OR \$ _____ PER _____</p> <p>998. DON'T KNOW</p>	<p>_____ PERCENT OR \$ _____ PER _____</p> <p>998. DON'T KNOW</p>
R24.	<p>AT AGE _____ OR IN _____ YEARS</p> <p>96. DON'T EXPECT BENEFITS</p> <p>TURN TO P. 85, R25--PLAN 2 TURN TO P. 85, R26--PLAN 2</p>	<p>AT AGE _____ OR IN _____ YEARS</p> <p>96. DON'T EXPECT BENEFITS</p> <p>TURN TO P. 85, R25--PLAN 3 TURN TO P. 85, R26--PLAN 3</p>

TYPE A -- PLAN 1

R25. About how much do you expect your benefits to be? (As a proportion of your pay at retirement, or as an amount per month or year when you start receiving them?)

\$ _____ PER _____
OR _____ PERCENT OF FINAL PAY

DON'T KNOW

R26. If you were to (leave this job/ sell this business) now, would you start receiving a monthly or annual pension benefit now, would you receive one later, would you get a cash settlement now, would you get nothing or what? (IF R SAYS "ROLL OVER" MARK "CASH SETTLEMENT".)

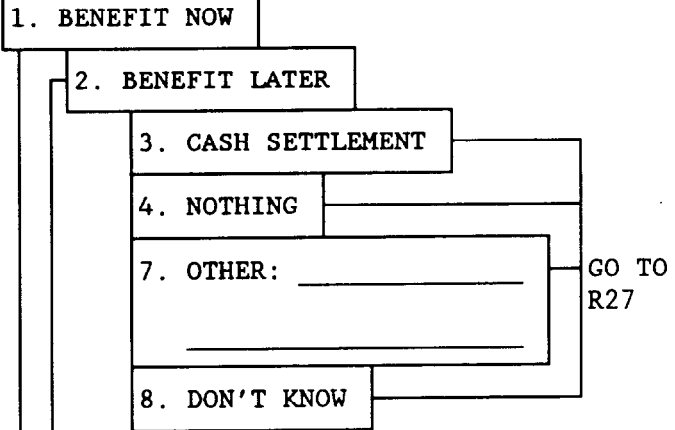

R26a. About how much per month would you receive?

\$ _____ PER MONTH

DON'T KNOW

R27. INTERVIEWER CHECKPOINT
(SEE R18, P. 82)

- 1. ONLY 1 PLAN-->TURN TO P. 90, R40
- 2. ALL OTHERS-->GO BACK TO P. 83, R19, PLAN 2

TYPE A -- PLAN 2

TYPE A -- PLAN 3

R25.

\$ _____ PER _____
OR _____ PERCENT OF FINAL PAY

DON'T KNOW

\$ _____ PER _____
OR _____ PERCENT OF FINAL PAY

DON'T KNOW

R26.

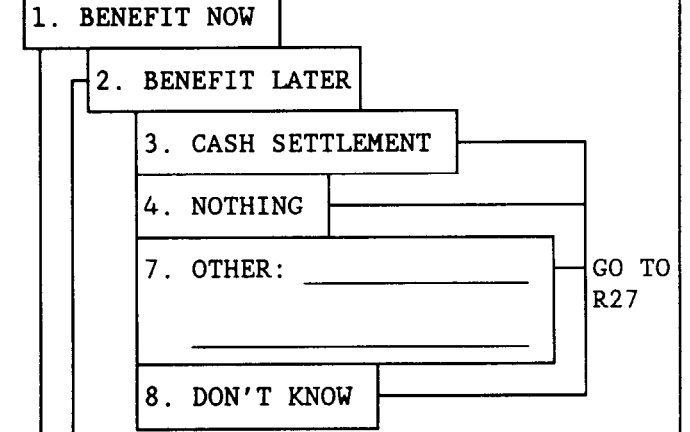
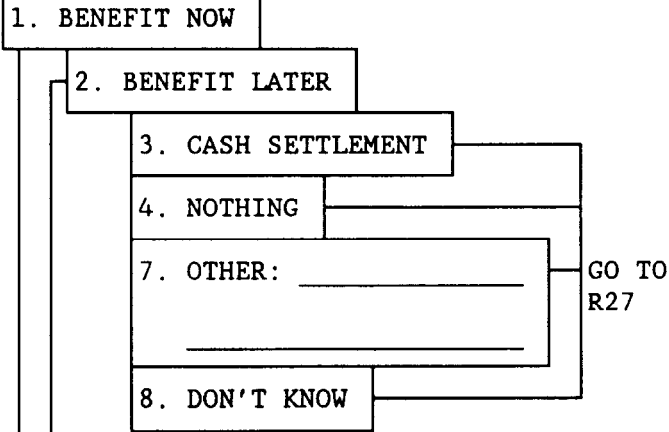

R26a

\$ _____ PER MONTH DON'T KNOW

\$ _____ PER MONTH DON'T KNOW

R27

- 1. ONLY 2 PLANS->TURN TO P. 90, R40
- 2. ALL OTHERS->GO BACK TO P. 83, R19, PLAN 3

- 1. ONLY 3 PLANS->TURN TO P. 90, R40
- 2. ALL OTHERS-->TURN TO P. 89, R39

SAVINGS & TYPE B -- PLAN 1

R35. If you needed money in an emergency, could you withdraw some of the funds in that account? (CHECK "YES" EVEN IF WITHDRAWAL INVOLVES PENALTY.)

1. YES

5. NO

8. DON'T KNOW

R36. If you were to (leave this job/sell the business) now, would you lose all, some, or none of the money in this account?

1. ALL

3. SOME

7. OTHER

5. NONE

R36a. What proportion would you lose?

_____ PERCENT

OR

R37. How is the money in this account invested? Is it mostly in stocks, mostly in interest earning assets, is it split between these, or what?

1. MOSTLY OR ALL STOCK

2. MOSTLY OR ALL INTEREST EARNING

3. SPLIT

7. OTHER: _____

8. DON'T KNOW

R38. INTERVIEWER CHECKPOINT
(SEE R18, P. 82)

1. ONLY 1 PLAN-->TURN TO P. 90, R40

2. ALL OTHERS-->GO BACK TO P. 83, R19, PLAN 2

SAVINGS & TYPE B -- PLAN 2

SAVINGS & TYPE B -- PLAN 3

R35.	<div style="display: flex; justify-content: space-around;"> <div style="border: 1px solid black; padding: 2px;">1. YES</div> <div style="border: 1px solid black; padding: 2px;">5. NO</div> <div style="border: 1px solid black; padding: 2px;">8. DON'T KNOW</div> </div>		<div style="display: flex; justify-content: space-around;"> <div style="border: 1px solid black; padding: 2px;">1. YES</div> <div style="border: 1px solid black; padding: 2px;">5. NO</div> <div style="border: 1px solid black; padding: 2px;">8. DON'T KNOW</div> </div>
R36.	<div style="display: flex; justify-content: space-between;"> <div style="border: 1px solid black; padding: 2px;">1. ALL</div> <div style="border: 1px solid black; padding: 2px;">3. SOME</div> <div style="border: 1px solid black; padding: 2px;">7. OTHER</div> </div> <div style="border: 1px solid black; padding: 2px; margin-top: 5px;">5. NONE</div>		<div style="display: flex; justify-content: space-between;"> <div style="border: 1px solid black; padding: 2px;">1. ALL</div> <div style="border: 1px solid black; padding: 2px;">3. SOME</div> <div style="border: 1px solid black; padding: 2px;">7. OTHER</div> </div> <div style="border: 1px solid black; padding: 2px; margin-top: 5px;">5. NONE</div>
	<p>R36a. What proportion would you lose?</p> <p>_____ PERCENT</p> <p>OR</p> <p>_____</p>		<p>R36a. What proportion would you lose?</p> <p>_____ PERCENT</p> <p>OR</p> <p>_____</p>
R37.	<div style="display: flex; justify-content: space-between;"> <div style="border: 1px solid black; padding: 2px;">1. MOSTLY OR ALL STOCK</div> <div style="border: 1px solid black; padding: 2px;">2. MOSTLY OR ALL INTEREST EARNING</div> <div style="border: 1px solid black; padding: 2px;">3. SPLIT</div> </div> <div style="border: 1px solid black; padding: 2px; margin-top: 5px;">7. OTHER: _____</div> <div style="border: 1px solid black; padding: 2px; margin-top: 5px;">8. DON'T KNOW</div>		<div style="display: flex; justify-content: space-between;"> <div style="border: 1px solid black; padding: 2px;">1. MOSTLY OR ALL STOCK</div> <div style="border: 1px solid black; padding: 2px;">2. MOSTLY OR ALL INTEREST EARNING</div> <div style="border: 1px solid black; padding: 2px;">3. SPLIT</div> </div> <div style="border: 1px solid black; padding: 2px; margin-top: 5px;">7. OTHER: _____</div> <div style="border: 1px solid black; padding: 2px; margin-top: 5px;">8. DON'T KNOW</div>
R38.	<div style="border: 1px solid black; padding: 5px; margin-bottom: 5px;"> <input type="checkbox"/> 1. ONLY 2 PLANS->NEXT PAGE, R40 </div> <div style="border: 1px solid black; padding: 5px;"> <input type="checkbox"/> 2. ALL OTHERS->GO BACK TO P. 83, R19, PLAN 3 </div>		<div style="border: 1px solid black; padding: 5px; margin-bottom: 5px;"> <input type="checkbox"/> 1. ONLY 3 PLANS->NEXT PAGE, R40 </div> <div style="border: 1px solid black; padding: 5px;"> <input type="checkbox"/> 2. ALL OTHERS </div>

R39. (IF 4 OR MORE) Altogether how much do you have in your account balance(s) for any other pension plans or savings plan(s) from this job?

\$ _____
NEXT PAGE, R40

DON'T KNOW

NOTHING

R39a. Altogether, what other benefit payments do you expect to receive from (this/these) other pension plan(s) from this job?

DON'T KNOW

NONE

R40. Are you doing any other work for pay now, such as a second job, the military reserves, or (another) business of your own?

1. YES

5. NO -->GO TO R44

R40a. Is this a second job, the military reserves, your own business, or what? (CHECK ALL THAT APPLY.)

A. SECOND JOB

B. MILITARY

C. BUSINESS

D. OTHER:

GO TO R41

GO TO R41

R40b. IWER: IF BUSINESS IS ONE OF THE BUSINESSES REPORTED IN SECTION M, MARK BOX.

R41. How many hours do you work on these other jobs in a normal week?

_____ #HOURS

R42. Counting paid vacations as weeks of work, how many weeks do you work on these other jobs in a normal year?

_____ # WEEKS

R43. About how much do you earn before taxes from these other jobs? (Is that per hour, week, month, year, or what?)

\$ _____ PER _____

R44. Thinking about all your current work for pay, do you consider yourself to be working full-time or part-time? (IF R IS LAID OFF OR A SEASONAL WORKER, ASK ABOUT "JOBS WHEN R IS WORKING".)

1. FULL-TIME

2. PART-TIME

--> TURN TO P. 93, R46

NEXT PAGE, R45

WORK HISTORY FOR R'S CURRENTLY WORKING FULL-TIME

R45. Now I have a few questions about your past jobs. Were you working for pay in January 1983?

1. YES

5. NO -->GO TO R45e



R45a. Was that January 1983 job with your present employer, another employer, were you self-employed, or what? (IF SELF-EMPLOYED BOTH IN 1983 AND NOW, CHECK "PRESENT EMPLOYER")

1. PRESENT EMPLOYER

GO TO R45e

2. DIFFERENT EMPLOYER

3. SELF-EMPL IN 1983, NOT NOW

4. SELF-EMPL NOW, NOT IN 1983

7. OTHER: _____

GO TO R45e



R45b. What was the reason you left (that job/self-employment)? Did you retire, become disabled, quit, were you laid off, did the business close, or what?

1. RETIRED

2. DISABLED

3. QUIT

4. LAID OFF

5. BUSINESS CLOSED

6. FIRED

7. OTHER: _____

R45c. Were you included in a pension or retirement plan on that job?

1. YES

5. NO -->GO TO R45e



R45d. Did you get a cash settlement from that pension plan, do you expect to get retirement benefits from that plan in the future, are you getting retirement benefits from that plan now, or what? (CHECK ALL THAT APPLY)

A. CASH SETTLEMENT

B. EXPECT FUTURE BENEFITS

C. GETTING BENEFITS NOW

D. NO BENEFITS

E. OTHER

READ: I will ask you about these benefits later. Now I want to ask about the last three years.



R45e. During the past 36 months, that is the last three years, how many months have you worked full-time?

_____ # OF MONTHS

R45f. How many different employers have you had on full-time jobs over the past 36 months?

_____ # OF EMPLOYERS

R45g. Have there been any months over this period when you only worked part-time?

1. YES 5. NO -----> GO TO R45m



R45h. How many of the past 36 months have you only worked part-time?

_____ # OF MONTHS

R45j. - R45k. NO QUESTIONS

R45m. Thinking now of the future, when do you expect to stop working full-time?

IN _____ YEARS OR AT AGE _____

96. NEVER STOP -->TURN TO P. 97, R49

R45n. Do you expect to work part-time after that?

1. YES 5. NO 8. DON'T KNOW/DEPENDS

TURN TO P. 97, R49



R45p. When do you expect to stop working altogether?

IN _____ YEARS OR AT AGE _____

98. DEPENDS/DK 96. NEVER STOP

TURN TO P. 97, R49

WORK HISTORY FOR R'S WORKING PART-TIME NOW

R46. Now I have a few questions about your past jobs. Were you working for pay in January 1983?

1. YES 5. NO -->GO TO R46e

R46a. Was that January 1983 job with your present employer, another employer, were you self-employed, or what? (IF SELF-EMPLOYED BOTH IN 1983 AND NOW, CHECK "PRESENT EMPLOYER")

- | | | | | |
|-----------------------------------|-----------------------|-------------------------------|-------------------------------|--------------------------|
| 1. PRESENT EMPLOYER
GO TO R46e | 2. DIFFERENT EMPLOYER | 3. SELF-EMPL IN 1983, NOT NOW | 4. SELF-EMPL NOW, NOT IN 1983 | 7. OTHER: _____
_____ |
|-----------------------------------|-----------------------|-------------------------------|-------------------------------|--------------------------|
- GO TO R46e

R46b. What was the reason you left (that job/self-employment)? Did you retire, become disabled, quit, were you laid off, did the business close, or what?

- | | | | | | |
|------------|-------------|---------|-------------|--------------------|----------|
| 1. RETIRED | 2. DISABLED | 3. QUIT | 4. LAID OFF | 5. BUSINESS CLOSED | 6. FIRED |
|------------|-------------|---------|-------------|--------------------|----------|
7. OTHER: _____

R46c. Were you included in a pension or retirement plan on that job?

1. YES 5. NO -->GO TO R46e

R46d. Did you get a cash settlement from that pension plan, do you expect to get retirement benefits from that plan in the future, are you getting retirement benefits from that plan now, or what? (CHECK ALL THAT APPLY)

- | | | | | |
|--------------------|---------------------------|-------------------------|----------------|----------|
| A. CASH SETTLEMENT | B. EXPECT FUTURE BENEFITS | C. GETTING BENEFITS NOW | D. NO BENEFITS | E. OTHER |
|--------------------|---------------------------|-------------------------|----------------|----------|

READ: I will ask you about these benefits later. Now I want to ask about the last three years.

R46e. During the past 36 months, that is the last three years, how many months have you worked part-time?

_____ # OF MONTHS

R46f. Have there been any months over this period when you worked full-time?

1. YES 5. NO -----> GO TO R46p



R46g. How many of the past 36 months have you worked full-time?

_____ # OF MONTHS

R46h. How many different employers have you had on full-time jobs over this time?

_____ # OF EMPLOYERS

R46i. When did you last work full-time for pay?

MONTH / YEAR

R46k. - R46n. NO QUESTIONS

R46p. Thinking now of the future, do you expect to do any full-time work for pay?

1. YES 5. NO 8. DON'T KNOW/DEPENDS

GO TO R46s



R46q. When do you expect to start working full-time?

IN _____ YEARS OR AT AGE _____ 98. DON'T KNOW/DEPENDS

R46r. And when do you expect to stop working full-time?

IN _____ YEARS OR AT AGE _____ 98. DON'T KNOW/DEPENDS 96. NEVER STOP

TURN TO
P. 97, R49

R46s. When do you expect to stop working for pay altogether?

IN _____ YEARS OR AT AGE _____ 98. DON'T KNOW/DEPENDS 96. NEVER STOP

TURN TO P. 97, R49

WORK HISTORY FOR R'S CURRENTLY RETIRED/DISABLED, HOMEMAKER, STUDENT, OR OTHER

R47. Now I have a few questions about your past jobs. Were you working for pay in January 1983?

1. YES

5. NO -->GO TO R47d



R47a. What was the reason you left that job? Did you retire, become disabled, quit, were you laid off, did the business close, or what?

1. RETIRED

2. DISABLED

3. QUIT

4. LAID OFF

5. BUSINESS CLOSED

6. FIRED

7. OTHER: _____

R47b. Were you covered by a pension or retirement plan on that job?

1. YES

5. NO -->GO TO R47d



R47c. Did you get a cash settlement from that pension plan, do you expect to get retirement benefits from that plan in the future, are you getting retirement benefits from that plan now, or what? (CHECK ALL THAT APPLY)

A. CASH
SETTLEMENT

B. EXPECT
FUTURE
BENEFITS

C. GETTING
BENEFITS
NOW

D. NO
BENEFITS

E. OTHER

READ: I will ask you about these benefits later.
Now I want to ask you about any work you
have done over the last three years.



R47d. During the last three years, or 36 months, have you done any work for pay?

1. YES

5. NO -->NEXT PAGE, R47p



R47e. How many months over this period have you worked full-time?

_____ # MONTHS

NONE -----> GO TO R47g

R47f. How many different employers have you had on full-time jobs over this time?

_____ # OF EMPLOYERS

R47g. How many months over this period have you only worked part-time?

_____ # MONTHS

NONE

R47h. - R47n. NO QUESTIONS

R47p. Do you expect to work for pay in the future?

1. YES

5. NO → NEXT PAGE, R49



R47q. When do you expect to start working?

IN _____ YEARS OR AT AGE _____

98. DON'T KNOW/DEPENDS

R47r. Will any of that be full-time work?

1. YES

5. NO

8. DON'T KNOW/DEPENDS



GO TO R47u

R47s. When do you expect to start working full-time?

IN _____ YEARS OR AT AGE _____

98. DON'T KNOW/DEPENDS

R47t. And when do you expect to stop working full-time?

IN _____ YEARS OR AT AGE _____

96. NEVER STOP



NEXT PAGE, R49

R47u. When do you expect to stop working for pay altogether?

IN _____ YEARS OR AT AGE _____

98. DON'T KNOW/DEPENDS

96. NEVER STOP

NEXT PAGE, R49

R49. INTERVIEWER CHECKPOINT:

SEE HHL UPDATE, ITEM #1

- 1. R IS MARRIED/LIVING WITH PARTNER----->GO TO SUPPLEMENTAL BOOKLET, P. 1, SECTION S
- 2. ALL OTHERS

IF SPOUSE/PARTNER IS PRESENT TRY TO OBTAIN SECTION S INFORMATION FROM (HIM/HER) DIRECTLY.

R50. Are you (or your [husband/wife]) currently receiving Social Security benefit payments, or any other type of pension, retirement, or disability benefit payment?

- 1. YES
- 5. NO → TURN TO P. 100, R52

R50a. Do these include Social Security benefit payments?

- 1. YES
- 5. NO → GO TO R51a

R50b. Are you both receiving Social Security payments or is only one of you? [Which one?]

INTERVIEWER: CHECK PERSON(S) (RESP, SPOUSE) IN R50c. THEN ASK FOLLOWUP QUESTIONS R50d-R50f FOR EACH.

R50c. RECIPIENT ----->

	RESPONDENT	SPOUSE
R50d. About (your/your [husband's/wife's]) Social Security benefits, are they for retirement or are they disability benefits?	<input type="checkbox"/> 1. RETIRE <input type="checkbox"/> 2. DISAB	<input type="checkbox"/> 1. RETIRE <input type="checkbox"/> 2. DISAB
R50e. How long (have you/has he/has she) received these benefits?	_____ # YEARS OR SINCE: _____	_____ # YEARS OR SINCE: _____
R50f. How much (do you/does he/does she) receive each month or year?	\$ _____ PER _____	\$ _____ PER _____

R51. Are you (or your [husband/wife]) currently receiving any other retirement, pension, or disability benefit payments?

- 1. YES
- 5. NO → TURN TO P. 100, R52

R51a. Not counting Social Security, how many retirement, pension or disability benefit payments are you (and your [husband/wife]) currently receiving?

PENSION/DISABILITY PAYMENTS

R51b. Who is receiving these benefit payments and what kind are they? (READ SLOWLY: Are they pensions from a current job, pensions from a past job, disability pensions, military pensions, or spousal pensions)?

IWER: MARK ONE RECIPIENT AND TYPE OF BENEFIT FOR ALL BENEFITS REPORTED. THEN ASK FOLLOWUP QUESTIONS R51d-R51h FOR EACH BENEFIT.

	FIRST BENEFIT		SECOND BENEFIT		THIRD BENEFIT	
RECIPIENT ----->	1. RESP	2. SPOUSE	1. RESP	2. SPOUSE	1. RESP	2. SPOUSE
R51c. TYPE OF BENEFIT -->	01. CURR JOB PENS		01. CURR JOB PENS		01. CURR JOB PENS	
	02. PAST JOB PENS		02. PAST JOB PENS		02. PAST JOB PENS	
	03. DISABILITY		03. DISABILITY		03. DISABILITY	
	04. MILITARY		04. MILITARY		04. MILITARY	
	05. SPOUSE PENS.		05. SPOUSE PENS.		05. SPOUSE PENS.	
	97. OTHER: _____		97. OTHER: _____		97. OTHER: _____	
R51d. About (RECIPIENT'S) (TYPE OF BENEFIT), how long (have you/has [he/she] received it?	_____ # YEARS OR SINCE: _____		_____ # YEARS OR SINCE: _____		_____ # YEARS OR SINCE: _____	
R51e. How much is received each month or year?	\$ _____ PER _____		\$ _____ PER _____		\$ _____ PER _____	
R51f. Has this benefit been increased when the cost of living has increased?	1. YES 5. NO		1. YES 5. NO		1. YES 5. NO	
R51g. INTERVIEWER CHECKPOINT (SEE HHL UPDATE, ITEM #1)	<input type="checkbox"/> 1. R MARRIED <input type="checkbox"/> 2. OTHERS GO TO R51j		<input type="checkbox"/> 1. R MARRIED <input type="checkbox"/> 2. OTHERS GO TO R51j		<input type="checkbox"/> 1. R MARRIED <input type="checkbox"/> 2. OTHERS GO TO R51j	
R51h. If (RECIPIENT) were to die, what percent of this benefit would (you/your husband/your wife) continue to receive or would the benefits stop?	_____ PERCENT <input type="checkbox"/> 96. STOP <input type="checkbox"/> 98. DK <input type="checkbox"/> 97. OTHER: _____		_____ PERCENT <input type="checkbox"/> 96. STOP <input type="checkbox"/> 98. DK <input type="checkbox"/> 97. OTHER: _____		_____ PERCENT <input type="checkbox"/> 96. STOP <input type="checkbox"/> 98. DK <input type="checkbox"/> 97. OTHER: _____	
R51j.	GO BACK TO R51d FOR NEXT BENEFIT OR TURN TO P. 100, R52		GO BACK TO R51d FOR NEXT BENEFIT OR TURN TO P. 100, R52		GO BACK TO R51d FOR NEXT BENEFIT OR TURN TO P. 100, R52	

IWER: BE SURE THAT ALL BENEFITS RECORDED IN R51a ARE ACCOUNTED FOR IN R51b-c

FOURTH BENEFIT FIFTH BENEFIT SIXTH BENEFIT

1. RESP	2. SPOUSE	1. RESP	2. SPOUSE	1. RESP	2. SPOUSE
01. CURR JOB PENS		01. CURR JOB PENS		01. CURR JOB PENS	
02. PAST JOB PENS		02. PAST JOB PENS		02. PAST JOB PENS	
03. DISABILITY		03. DISABILITY		03. DISABILITY	
04. MILITARY		04. MILITARY		04. MILITARY	
05. SPOUSE PENS.		05. SPOUSE PENS.		05. SPOUSE PENS.	
97. OTHER: _____		97. OTHER: _____		97. OTHER: _____	
_____ # YEARS OR SINCE: _____		_____ # YEARS OR SINCE: _____		_____ # YEARS OR SINCE: _____	
\$ _____ PER _____		\$ _____ PER _____		\$ _____ PER _____	
<input type="checkbox"/> 1. YES <input type="checkbox"/> 5. NO		<input type="checkbox"/> 1. YES <input type="checkbox"/> 5. NO		<input type="checkbox"/> 1. YES <input type="checkbox"/> 5. NO	
<input type="checkbox"/> 1.R MARRIED ↓ <input type="checkbox"/> 2.OTHERS GO TO R51j		<input type="checkbox"/> 1.R MARRIED ↓ <input type="checkbox"/> 2.OTHERS GO TO R51j		<input type="checkbox"/> 1.R MARRIED ↓ <input type="checkbox"/> 2.OTHERS GO TO R51j	
_____ PERCENT <input type="checkbox"/> 96.STOP <input type="checkbox"/> 98.DK <input type="checkbox"/> 97. OTHER: _____		_____ PERCENT <input type="checkbox"/> 96.STOP <input type="checkbox"/> 98.DK <input type="checkbox"/> 97. OTHER: _____		_____ PERCENT <input type="checkbox"/> 96.STOP <input type="checkbox"/> 98.DK <input type="checkbox"/> 97. OTHER: _____	
GO BACK TO R51d FOR NEXT BENEFIT OR NEXT PAGE, R52		GO BACK TO R51d FOR NEXT BENEFIT OR NEXT PAGE, R52		NEXT PAGE, R52	

R52. Have you (or your [husband/wife]) ever received a cash settlement from a pension or retirement plan of a previous job?

1. YES

5. NO --> GO TO R53



R52a. How many different cash settlements have you (or your [husband/wife]) received?

CASH SETTLEMENTS

R52b. FOR EACH SETTLEMENT: Who received it, about how much was received, and when was it received?

	R52b <u>WHO</u>		R52c <u>AMOUNT</u>	R52d <u>YEAR RECEIVED</u>
Cash settlement #1	R (1)	S (2)	\$ _____	_____
Cash settlement #2	R (1)	S (2)	\$ _____	_____
Cash settlement #3	R (1)	S (2)	\$ _____	_____
Cash settlement #4	R (1)	S (2)	\$ _____	_____
Cash settlement #5	R (1)	S (2)	\$ _____	_____

R53. Now I want to ask about future pension benefits that you (and your [husband/wife]) have earned rights to. Aside from Social Security and any pension benefits you have already told me about, do you (and your [husband/wife]) expect to receive any (other) pension benefits in the future from any past jobs?

1. YES

5. NO -->TURN TO P. 102, SECTION T



TURN TO P. 101a, R53a

THIS IS A BLANK PAGE

101a

R53a. How many such benefits do you (and your [husband/wife]) expect to receive in the future?

FUTURE BENEFITS

R53b. About (this/the largest/the next) benefit, is this from a pension plan where a certain amount of money is accumulated in an account for you, a formula plan that will give you a specific amount of income each month or year when you retire, or what?

	COLUMN A	COLUMN B	COLUMN C
	<input type="checkbox"/> 2. ACCOUNT <input type="checkbox"/> 3. BOTH <input type="checkbox"/> 1. INCOME FORMULA GO TO R53d	<input type="checkbox"/> 2. ACCOUNT <input type="checkbox"/> 3. BOTH <input type="checkbox"/> 1. INCOME FORMULA GO TO R53d	<input type="checkbox"/> 2. ACCOUNT <input type="checkbox"/> 3. BOTH <input type="checkbox"/> 1. INCOME FORMULA GO TO R53d
R53c. How much is in the account now?	\$ _____	\$ _____	\$ _____
R53d. Is this part of an IRA, Keogh, or pension I recorded earlier? (Which?)	1. YES, IRA/KEO	1. YES, IRA/KEO	1. YES, IRA/KEO
	2. YES, PENSION	2. YES, PENSION	2. YES, PENSION
	5. NO	5. NO	5. NO
R53e. Is this benefit based on <u>your</u> earnings (or your [husband's/wife's] earnings)?	1. R	1. R	1. R
	2. SPOUSE	2. SPOUSE	2. SPOUSE
	7. OTHER: _____ _____	7. OTHER: _____ _____	7. OTHER: _____ _____
R53f. When do you expect these benefits to start?	AT AGE _____	AT AGE _____	AT AGE _____
	OR IN _____ YRS	OR IN _____ YRS	OR IN _____ YRS
R53g. About how much per month do you expect them to be?	\$ _____ PER _____	\$ _____ PER _____	\$ _____ PER _____
R53h. INTERVIEWER CHECKPOINT (SEE R53a)	<input type="checkbox"/> 1. MORE THAN 1 BENEFIT GO BACK TO R53b, COL.B <input type="checkbox"/> 2. ALL OTHERS TURN TO P. 102 SECTION T	<input type="checkbox"/> 1. MORE THAN 2 BENEFITS GO BACK TO R53b, COL.C <input type="checkbox"/> 2. ALL OTHERS TURN TO P. 102 SECTION T	<input type="checkbox"/> 1. MORE THAN 3 BENEFITS GO BACK TO R53b, COL.D <input type="checkbox"/> 2. ALL OTHERS TURN TO P. 102 SECTION T

COLUMN D	COLUMN E	COLUMN F												
<div style="border: 1px solid black; padding: 5px; margin-bottom: 5px;">2. ACCOUNT</div> <div style="border: 1px solid black; padding: 5px; margin-bottom: 5px;">3. BOTH</div> <div style="border: 1px solid black; padding: 5px; margin-bottom: 5px;">1. INCOME FORMULA</div> <p>GO TO R53d</p>	<div style="border: 1px solid black; padding: 5px; margin-bottom: 5px;">2. ACCOUNT</div> <div style="border: 1px solid black; padding: 5px; margin-bottom: 5px;">3. BOTH</div> <div style="border: 1px solid black; padding: 5px; margin-bottom: 5px;">1. INCOME FORMULA</div> <p>GO TO R53d</p>	<div style="border: 1px solid black; padding: 5px; margin-bottom: 5px;">2. ACCOUNT</div> <div style="border: 1px solid black; padding: 5px; margin-bottom: 5px;">3. BOTH</div> <div style="border: 1px solid black; padding: 5px; margin-bottom: 5px;">1. INCOME FORMULA</div> <p>GO TO R53d</p>												
<p>\$ _____</p>	<p>\$ _____</p>	<p>\$ _____</p>												
<p>1. YES, IRA/KEO</p>	<p>1. YES, IRA/KEO</p>	<p>1. YES, IRA/KEO</p>												
<p>2. YES, PENSION</p>	<p>2. YES, PENSION</p>	<p>2. YES, PENSION</p>												
<p>5. NO</p>	<p>5. NO</p>	<p>5. NO</p>												
<table border="1" style="width: 100%; border-collapse: collapse;"> <tr> <td style="width: 50%; padding: 5px;">1. R</td> <td style="width: 50%;"></td> </tr> <tr> <td style="padding: 5px;">2. SPOUSE</td> <td></td> </tr> </table>	1. R		2. SPOUSE		<table border="1" style="width: 100%; border-collapse: collapse;"> <tr> <td style="width: 50%; padding: 5px;">1. R</td> <td style="width: 50%;"></td> </tr> <tr> <td style="padding: 5px;">2. SPOUSE</td> <td></td> </tr> </table>	1. R		2. SPOUSE		<table border="1" style="width: 100%; border-collapse: collapse;"> <tr> <td style="width: 50%; padding: 5px;">1. R</td> <td style="width: 50%;"></td> </tr> <tr> <td style="padding: 5px;">2. SPOUSE</td> <td></td> </tr> </table>	1. R		2. SPOUSE	
1. R														
2. SPOUSE														
1. R														
2. SPOUSE														
1. R														
2. SPOUSE														
<p>7. OTHER:</p> <p>_____</p> <p>_____</p>	<p>7. OTHER:</p> <p>_____</p> <p>_____</p>	<p>7. OTHER:</p> <p>_____</p> <p>_____</p>												
<p>AT AGE _____</p> <p style="text-align: center;">OR</p> <p>IN _____ YRS</p>	<p>AT AGE _____</p> <p style="text-align: center;">OR</p> <p>IN _____ YRS</p>	<p>AT AGE _____</p> <p style="text-align: center;">OR</p> <p>IN _____ YRS</p>												
<p>\$ _____ PER _____</p>	<p>\$ _____ PER _____</p>	<p>\$ _____ PER _____</p>												
<p><input type="checkbox"/> 1. MORE THAN 4 BENEFITS GO BACK TO R53b, COL. E</p> <p><input type="checkbox"/> 2. ALL OTHERS NEXT PAGE, SECTION T</p>	<p><input type="checkbox"/> 1. MORE THAN 5 BENEFITS GO BACK TO R53b, COL. F</p> <p><input type="checkbox"/> 2. ALL OTHERS NEXT PAGE, SECTION T</p>	<p>NEXT PAGE, SECTION T</p>												

SECTION T: INCOME

T1. We have talked about various sources of income. Now we would like to get the overall picture of all the different sources of income that you (and members of your family living here) had in 1988. Did (you/anyone) have income from wages and salaries, including bonuses, overtime and commissions? (RECORD IN COLUMN T1 AND ASK T2 FOR EACH SOURCE OF INCOME AS IT IS MENTIONED.)

IWER: RECORD LOSS IN ();
E.G. (\$1,500)

T2. In total, how much income from (SOURCE) did you (and your family) receive in 1988, before deductions for taxes and anything else? [WRITE LOSSES ().]

NO YES
(5) (1)

	NO (5)	YES (1)	
T1a. WAGES AND SALARIES?			--> \$ _____
T1b. Did (you/anyone) have income or loss from a professional practice, business or farm? (Other than wages or salaries)			--> \$ _____
T1c. ...non-taxable investments such as municipal bonds?			--> \$ _____
T1d. ...other interest income?			--> \$ _____
T1e. ...dividends?			--> \$ _____
T1f. ...net gains or losses from the sale of stocks, bonds, or real estate?			--> \$ _____
T1g. ...net rent, trust income, or royalties from any other investment or business?			--> \$ _____
T1h. ...unemployment or worker's compensation?			--> \$ _____
T1j. ...child support or alimony?			--> \$ _____
T1k. Did (you/anyone) have income from ADC AFDC, food stamps, or other forms of welfare or assistance, such as SSI?			--> \$ _____
T1m. ...income from Social Security or other pensions, annuities, or other disability or retirement programs?			--> \$ _____
T1n. Did you (or anyone in your family living here) have income from <u>any</u> other sources? (What other sources?)			--> \$ _____
_____			--> \$ _____
_____			--> \$ _____

T3. How much was the total income you (and your family living here) received in 1988 from all sources, before taxes and other deductions were made?

\$ _____
GO TO T5

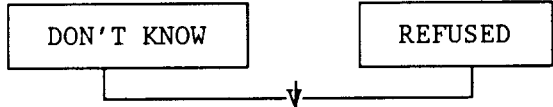

T4. Did you (and your family living here) receive more than \$30,000 in 1988?

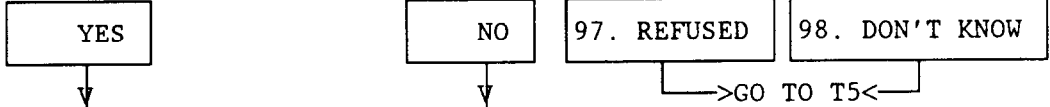

T4a. Was it \$50,000 or more?
 YES 05. NO DK REFUSED
 GO TO T5

T4b. Was it \$100,000 or more?
 YES 06. NO DK REFUSED
 GO TO T5

T4c. Was it \$250,000 or more?
 08. YES 07. NO DK REFUSED

T4d. Was it \$5,000 or more?
 YES 01. NO DK REFUSED
 GO TO T5

T4e. Was it \$10,000 or more?
 YES 02. NO DK REFUSED
 GO TO T5

T4f. Was it \$20,000 or more?
 04. YES 03. NO REFUSED

T5. During 1988, did you (or anyone in your family living here) pay any alimony or child support?



T5a. Altogether, how much alimony and/or child support did you (and your family) pay in 1988?

\$ _____

T6. During 1988, did you (or anyone in your family living here) provide any (other) financial support for relatives or friends who do not live here?

1. YES 5. NO --> GO TO T7

T6a. How much support did you (and your family) pay?
 \$ _____

T6b. To whom was this support given? (Anyone else?) (CHECK ALL THAT APPLY.)

A. CHILDREN UNDER 18	B. CHILDREN 18 AND OVER	C. PARENTS (IN-LAW)	D. GRAND CHILDREN	E. GRAND PARENTS
F. SIBLINGS (IN-LAW)	G. NIECE/ NEPHEW	H. FRIEND	J. OTHER: _____	

T7. Did you (or your [husband/wife]) file or do you expect to file a 1988 Federal Income tax return?

1. YES 5. NO 7. REFUSED 8. DON'T KNOW

NEXT PAGE, T8

T7a. INTERVIEWER CHECKPOINT--SEE HHL UPDATE, ITEM #1

1. R MARRIED
 2. ALL OTHERS--->GO TO T7c

T7b. Did you and your (husband/wife) file a joint return, did you file separately, or did only one of you file? (Which one?)

1. FILE JOINTLY	2. FILE SEPARATE	3. ONLY R FILE	4. ONLY S FILE	8. DK
-----------------	------------------	----------------	----------------	-------

T7c. Did you (or your [husband/wife]) file a Schedule C, E or F with your return? (CHECK ALL THAT APPLY.) (IF R ASKS: SCHEDULE "C" IS FOR BUSINESS INCOME, "E" IS FOR TRUST AND PARTNERSHIP INCOME, AND "F" IS FOR FARM INCOME.)

A. SCHED C	B. SCHED E	C. SCHED F	D. NO
------------	------------	------------	-------

T7d. Approximately what was your (and your [husband's/wife's]) total adjusted gross income (AGI) on your 1988 return? (What do you think it will be?)

\$ _____ DON'T KNOW REFUSED

T8. Now I'd like to ask you some questions about your (family's) income in previous years. How much was the total income you (and your family living here) received in 1987 from all sources, before taxes and other deductions were made?

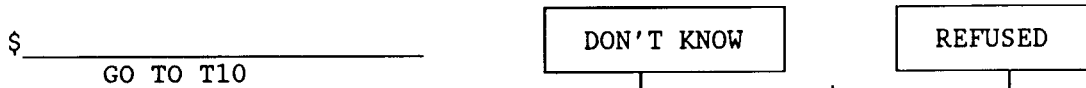

T9. Did you (and your family living here) receive more than \$30,000 in 1987?

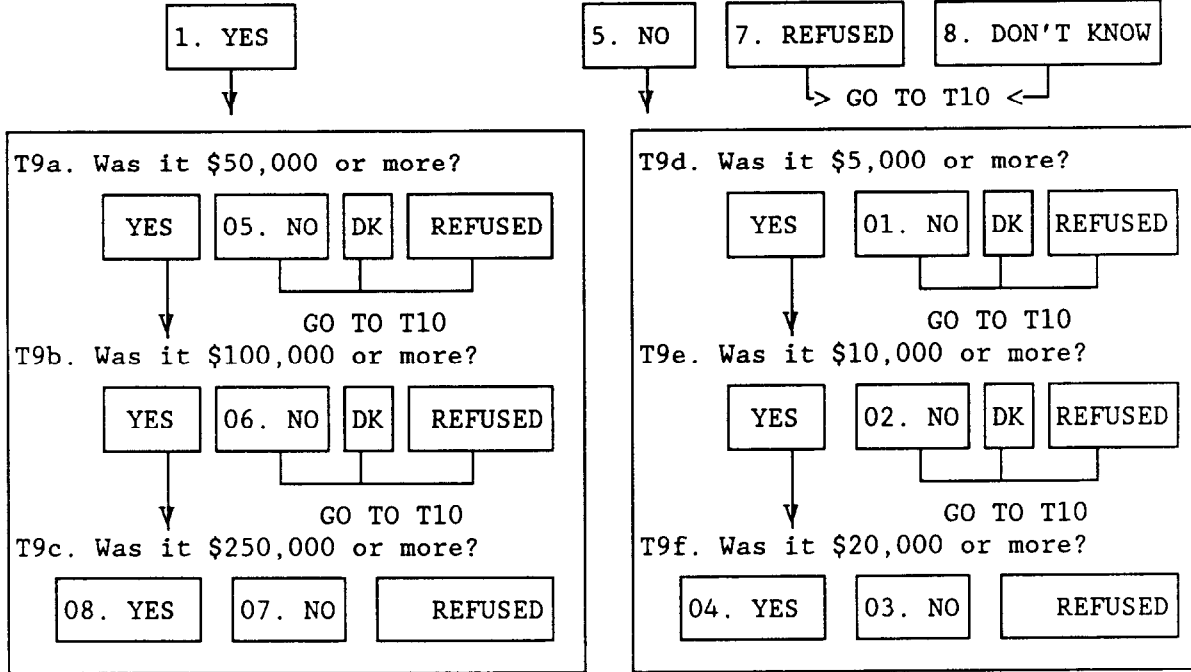

T10. How much was the total income you (and your family living here) received in 1986 from all sources, before taxes and other deductions were made?

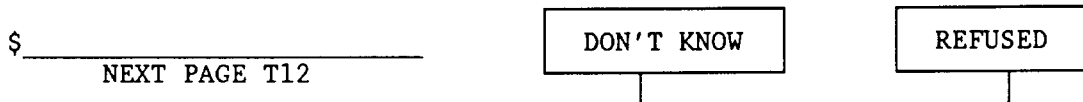

T11. Did you (and your family living here) receive more than \$30,000 in 1986?

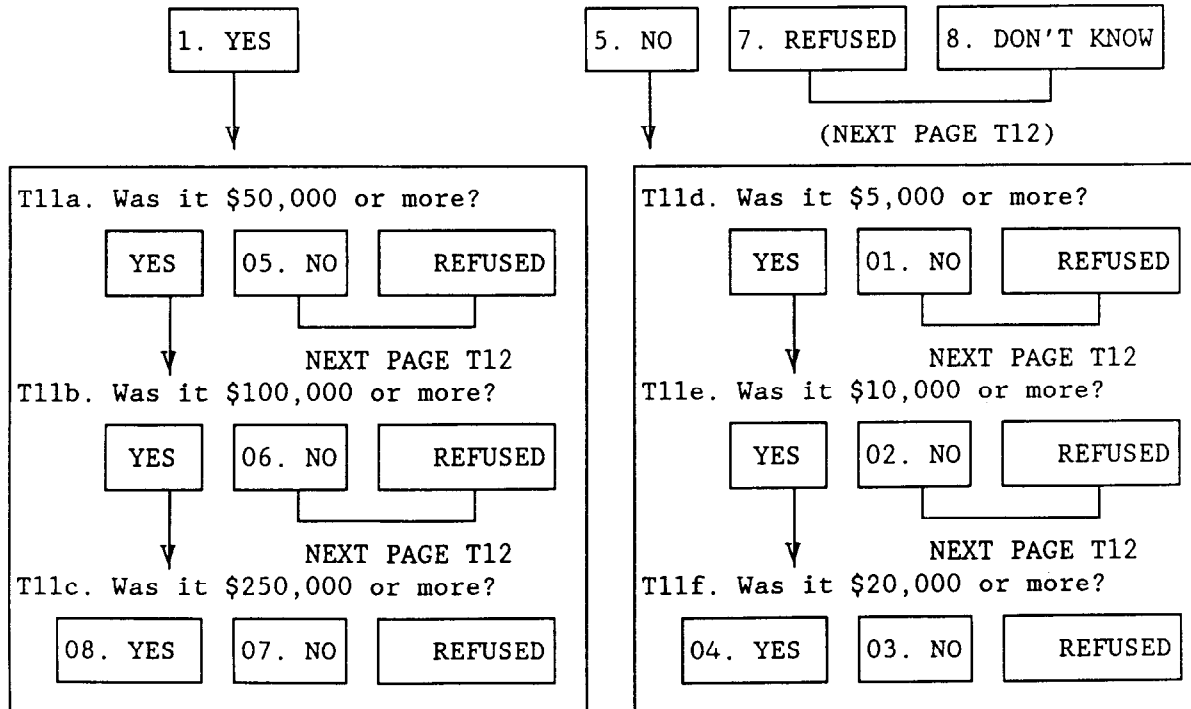

T12. During either 1986 or 1987, did you (or anyone in your family living there) receive any income from ADC, AFDC, SSI, or other public assistance?

1. YES

5. NO

T13. During either 1986 or 1987, did you (or anyone in your family living there) receive any worker's compensation or unemployment benefits?

1. YES

5. NO

T14. During either 1986 or 1987, did you (or anyone in your family living here) receive any financial support from relatives or friends who do not live here, or receive any alimony or child support payments?

1. YES

5. NO --> GO TO T15



T14a. Altogether, about how much such support did you (and your family) receive in 1986 and 1987?

\$ _____

T15. During either 1986 or 1987, did you (or anyone in your family living here) provide any financial support for relatives or friends who do not live here, or pay any alimony or child support?

1. YES

5. NO --> NEXT PAGE, SECTION X



T15a. Altogether, about how much such support did you (and your family) provide in 1986 and 1987?

\$ _____

SECTION X: CHARITY AND INTER-FAMILY TRANSFERS

X1. Have you (or your [husband/wife]) ever received an inheritance, or been given substantial assets in a trust or in some other form?

1. YES

5. NO -->NEXT PAGE, X9



X2. How many of these have you (or your [husband/wife]) ever received?

OF INHERITANCES, TRUSTS, OTHER TRANSFERS

	INHERITANCE # 1	INHERITANCE # 2	INHERITANCE # 3
X3. (Thinking about the [largest/next largest] of these) was that an inheritance, a trust, or what? (CHECK ALL THAT APPLY.)	1. INHERITANCE	1. INHERITANCE	1. INHERITANCE
	2. TRUST	2. TRUST	2. TRUST
	7. OTHER	7. OTHER	7. OTHER
X4. What was its approximate value at the time it was received?	\$ _____ <input type="checkbox"/> DON'T KNOW	\$ _____ <input type="checkbox"/> DON'T KNOW	\$ _____ <input type="checkbox"/> DON'T KNOW
X5. In what year was it received?	19 _____	19 _____	19 _____
X6. From whom was it received?	01. GRNDPRNT	01. GRNDPRNT	01. GRNDPRNT
	02. PARENT	02. PARENT	02. PARENT
	03. CHILD	03. CHILD	03. CHILD
	04. AUNT/UNCLE	04. AUNT/UNCLE	04. AUNT/UNCLE
	05. SIBLING	05. SIBLING	05. SIBLING
	06. FRIEND	06. FRIEND	06. FRIEND
	97. OTHER: _____	97. OTHER: _____	97. OTHER: _____
X7. INTERVIEWER CHECKPOINT (SEE X2)	<input type="checkbox"/> 1. ONLY 1 INHER NEXT P., X9	<input type="checkbox"/> 1. ONLY 2 INHER NEXT P., X9	<input type="checkbox"/> 1. ONLY 3 INHER NEXT P., X9
	<input type="checkbox"/> 2. ALL OTHERS GO BACK TO X3, COL #2	<input type="checkbox"/> 2. ALL OTHERS GO BACK TO X3, COL #3	<input type="checkbox"/> 2. ALL OTHERS NEXT PAGE, X8

X8. How much altogether were any others you have received?

\$ _____

X9. Do you (or your [husband/wife]) expect to receive a substantial inheritance or transfer of assets in the future?

1. YES

5. NO -->GO TO X10



X9a. Is that likely to involve a large amount of money, a moderate amount, or what?

1. LARGE

2. MODERATE

7. OTHER: _____

8. DON'T KNOW

X9b. IWER: RECORD AMOUNT IF R VOLUNTEERS IT: \$ _____

X10. During 1988, did you (or anyone in your family living here) make charitable contributions of money or property totaling \$500 or more?

1. YES

5. NO -->GO TO X11



X10a. Roughly, how much did (you/your family) contribute?

\$ _____

X11. Some people think it is important to leave an estate or inheritance to their surviving heirs, while others don't. Which is closer to your (and your [husband's/wife's]) feelings? Would you say it is very important, important, somewhat important, or not important?

1. VERY IMPORTANT

2. IMPORTANT

3. R & S DIFFER

4. SOMEWHAT IMPORTANT

5. NOT IMPORTANT

X12. Do you (and your [husband/wife]) expect to leave a sizeable estate to others?

1. YES

3. POSSIBLY

5. NO

SECTION V: CHANGES IN FAMILY FINANCES

V1. Now I'd like to ask you some questions about the changes in your (family's) finances over the past several years. Since January 1983, have you (or anyone living here) bought or sold a home that was your primary residence?

1. YES

5. NO --> TURN TO P. 111, V2

V1a. Did you only buy, only sell, both buy and sell, or what?

1. ONLY BOUGHT

2. ONLY SOLD

3. BOTH BOUGHT AND SOLD

TURN TO P. 111, V2

NEXT PAGE, V1b

V1b. In what month and year did you most recently sell a home?

MONTH/YEAR

V1c. What was the selling price?

\$ _____

V1d. And when did you buy that home?

MONTH/YEAR

V1e. What was the purchase price?

\$ _____

V1f. Since January 1983, have you sold any other home that was your primary residence?

1. YES

5. NO

-->NEXT PAGE, V2



V1g. In what month and year was this other home sold? (IF MORE THAN ONE, RECORD MOST RECENT SALE)

MONTH/YEAR

V1h. What was the selling price?

\$ _____

V1j. And when did you buy that home?

MONTH/YEAR

V1k. What was the purchase price?

\$ _____

V2. Since January 1983, did you (or anyone in your family living here) make any major additions or home improvements to a primary residence that you owned? (Do not count general maintenance or upkeep.)

1. YES

5. NO -->GO TO V4



V2a. What was the dollar cost of these additions and improvements, plus the value of any work you may have done yourself?

\$ _____

DK

REFUSED



USE CARD B

V3. No Question

V4. Since January 1983, have you (or anyone in your family living here) sold any real estate other than your principal residence, such as a vacation home, land, or rental or investment property?

1. YES

5. NO --->



V4a. Have you bought any such real estate properties since January 1983?

1. YES 5. NO -->NEXT PAGE, V6d

GO TO V5a

V4b. How many such real estate properties have you sold since January 1983?

ONE

_____ # PROPERTIES SOLD--->NEXT PAGE, V6



V4c. In what month and year did you sell that property? _____ / _____
MONTH YEAR

V4d. About how much did you sell it for?

\$ _____

DON'T KNOW

REFUSED



USE CARD B

V5. Have you also bought any such real estate properties since January 1983?

1. YES

5. NO --->NEXT PAGE V7



V5a. About how much in total did you pay for this real estate?

\$ _____

DON'T KNOW REFUSED

USE CARD B

NEXT PAGE, V7

V6. Did you also buy any real estate of this sort since January 1983?

1. YES 5. NO --->

GO TO V6b

V6a. About how much in total was the dollar value of the real estate you sold since January 1983?

\$ _____

DON'T KNOW

REFUSED

USE CARD B

GO TO V7

V6b. Overall, was the dollar value of the real estate you bought greater than the dollar value of what you sold, less than the value of what you sold, about equal, or what?

1. BOUGHT MORE
THAN SOLD

2. BOUGHT LESS
THAN SOLD

3. BOUGHT AND SOLD
ABOUT EQUAL AMOUNTS

8. DON'T KNOW

GO TO V7

V6c. Roughly, about how much (more/less) did you buy than you sold?

\$ _____

DON'T KNOW

REFUSED

USE CARD B

GO TO V7

V6d. INTERVIEWER CHECKPOINT

SEE E14, P. 31

1. R ANSWERED "YES" - OWNS REAL ESTATE

2. R ANSWERED "NO" --> NEXT PAGE, V8

V7. Since January 1983, did you (or your family living here) make major additions or improvements to any real estate properties that you own? Do not count general maintenance or upkeep.

1. YES 5. NO --> NEXT PAGE V8

V7a. What was the dollar cost of these additions and improvements, plus the value of any work you may have done yourself?

\$ _____

DK

REFUSED

USE CARD B

V8. Since January 1983, have you (or your family living here) put personal funds into a privately held business, professional practice, partnership or farm that you own or share ownership in?

1. YES

5. NO -->GO TO V9

V8a. Altogether, about how much new money did you (or your family living here) put into that, including any funds that you borrowed personally?

\$ _____

DK

REFUSED

USE CARD B

V9. Since January 1983, have you (or your family living here) sold part or all of any interest in a privately held business, professional practice, partnership, or farm?

1. YES

5. NO --GO TO V10

V9a. Altogether, about how much did you (or your family living here) sell your interest for? (What was the selling price?) (IWER: WE WANT THE PRICE THE BUYER PAID.)

\$ _____

DK

REFUSED

USE CARD B

V9b. In what month and year did you sell that? (MOST RECENT SALE, IF MORE THAN ONE.)

_____/_____
MONTH/YEAR

V10. Since January 1983, have you (or anyone in your family living here) put money into or taken money out of any IRA or Keogh accounts?

1. YES

5. NO --> NEXT PAGE V11

V10a. Did you (or anyone in your family) put money in or take money out?

1. PUT IN

2. TAKE OUT

3. BOTH ----->NEXT PAGE V11

V10b. Altogether, about how much did you (put in/take out)?

\$ _____

DON'T KNOW

REFUSED

USE CARD B

V11. Not counting any IRAs, Keoghs or pension accounts, since January 1983, have you (or anyone in your family living here) bought any shares of stock in publicly held corporations, or put money into mutual funds, managed investment accounts or trusts, including any automatic reinvestment?

1. YES 5. NO -->GO TO V15

V12. Did you (or your family living with you) also sell or cash in any such assets?

1. YES 5. NO -->GO TO V14

V13. Did you buy more or sell more--that is, overall, did you put money into stocks, mutual funds, managed investment accounts or trusts, take money out of them, or put in about as much as you took out?

1. PUT MONEY IN 2. TAKE MONEY OUT 3. PUT IN ABOUT AS MUCH AS TOOK OUT

NEXT PAGE V16

V13a. About how much more money did you (or your family living here) (put in/take out)?
\$ _____ DON'T KNOW REFUSED

USE CARD B

NEXT PAGE, V16

V14. Altogether, how much money (including any automatic reinvestment) did you (or your family living here) put in?

\$ _____ DON'T KNOW REFUSED

USE CARD B

NEXT PAGE, V16

V15. Since January 1983, have you (or anyone in your family living here) sold any shares of stock in publicly held corporations or taken money out of any mutual funds, managed investment accounts or trusts?

1. YES 5. NO -->NEXT PAGE V16

V15a. Altogether, how much money did you (or your family living here) get from that?

\$ _____ DON'T KNOW REFUSED

USE CARD B

V16. Since January 1983 have you done any work for pay?

1. YES

5. NO -->NEXT PAGE, V18



V17. Not counting IRAs or Keoghs, have you been included in any employer-sponsored pension or retirement plan, or in any tax-deferred saving plan, since January 1983?

1. YES

5. NO -->NEXT PAGE, V18



V17a. Have you contributed to any of these plans, such as by having money deducted from your pay? (INCLUDE CONTRIBUTIONS THROUGH UNION DUES OR OTHER SOURCES)

1. YES

5. NO -->NEXT PAGE, V18



V17b. For each year beginning with 1983, about what percent of pay or amount of money per month or year have you contributed to these plans?

DON'T KNOW YEAR-BY-YEAR

-->V17c. Altogether during this period, about how much would you guess?

_____ % OR _____ PER _____

OR

\$ _____
USE CARD B, IF NECESSARY

(About what percent of pay or amount of money per month or year have you contributed...)

V17d. First, in 1983? _____ % OF PAY AND/OR \$ _____ PER _____

V17e. ... in 1984? _____ % OF PAY AND/OR \$ _____ PER _____

V17f. ... in 1985? _____ % OF PAY AND/OR \$ _____ PER _____

V17g. ... in 1986? _____ % OF PAY AND/OR \$ _____ PER _____

V17h. ... in 1987? _____ % OF PAY AND/OR \$ _____ PER _____

V17j. ... in 1988? _____ % OF PAY AND/OR \$ _____ PER _____

V17k. ... in 1989? _____ % OF PAY AND/OR \$ _____ PER _____

V18. INTERVIEWER CHECKPOINT

SEE HHL UPDATE, ITEM #1

1. R MARRIED OR LIVING WITH PARTNER,
 2. ALL OTHERS--->NEXT PAGE, V20

V19. Since January 1983 has your (husband/wife) done any work for pay?

1. YES 5. NO -->NEXT PAGE, V20

V19a. Not counting IRAs or Keoghs, has (he/she) been included in any employer-sponsored pension or retirement plan, or in any tax-deferred saving plan, since January 1983?

1. YES 5. NO -->NEXT PAGE, V20

V19b. Has (he/she) contributed to any of these plans, such as by having money deducted from (his/her) pay? (INCLUDE CONTRIBUTIONS THROUGH UNION DUES OR OTHER SOURCES)

1. YES 5. NO -->NEXT PAGE, V20

V19c. For each year beginning with 1983, about what percent of pay or amount of money per month or year has (he/she) contributed to these plans?

DON'T KNOW YEAR-BY-YEAR -->V19d.

Altogether during this period, about how much would you guess?

_____ % OR _____ PER _____

OR

\$ _____
 USE CARD B, IF NECESSARY

(About what percent of pay or amount of money per month or year has (he/she) contributed...)

V19e. First, in 1983?	_____ % OF PAY AND/OR \$ _____ PER _____	<input type="checkbox"/> NONE
V19f. ... in 1984?	_____ % OF PAY AND/OR \$ _____ PER _____	<input type="checkbox"/> NONE
V19g. ... in 1985?	_____ % OF PAY AND/OR \$ _____ PER _____	<input type="checkbox"/> NONE
V19h. ... in 1986?	_____ % OF PAY AND/OR \$ _____ PER _____	<input type="checkbox"/> NONE
V19j. ... in 1987?	_____ % OF PAY AND/OR \$ _____ PER _____	<input type="checkbox"/> NONE
V19k. ... in 1988?	_____ % OF PAY AND/OR \$ _____ PER _____	<input type="checkbox"/> NONE
V19m. ... in 1989?	_____ % OF PAY AND/OR \$ _____ PER _____	<input type="checkbox"/> NONE

V20. Sometimes changes in a family's savings or assets are due to people joining or leaving the family. Was there anyone living with you in 1983 who doesn't live with you now and who took \$5,000 or more in assets or debts away with them? (IF R ASKS: DO NOT INCLUDE SPOUSE)

1. YES

5. NO

GO TO V21

V20a. Altogether, what is the total dollar value of assets that were removed that way?

\$ _____

DON'T KNOW

REFUSED

USE CARD B

V20b. Altogether, what is the total dollar value of debts that were removed that way?

\$ _____

DON'T KNOW

REFUSED

USE CARD B

V21. INTERVIEWER CHECKPOINT:

SEE HHL UPDATE, ITEM 9a

1. R LIVES ALONE-->NEXT PAGE, V26

2. ALL OTHERS

V22. Is there anyone in your family living with you now who has joined the family since 1983 and who had \$5,000 or more in assets or debts at the time they joined the family? (IF R ASKS: DO NOT INCLUDE NEW SPOUSE)

1. YES

5. NO

--> NEXT PAGE, V26

V22a. Altogether, what is the total dollar value of assets that were brought into the family in that way?

\$ _____

DON'T KNOW

REFUSED

USE CARD B

V22b. Altogether, what is the total dollar value of debts that were brought into the family in that way?

\$ _____

DON'T KNOW

REFUSED

USE CARD B

V23-25. NO QUESTION

V26. Since 1983, have you (or your [husband/wife]) or any of your children attended college or trade school?

1. YES

5. NO -->NEXT PAGE, V28

V26a. Did you attend school, (did your [husband/wife]), or did your children? (CHECK ALL THAT APPLY, AND ASK ALL FOLLOWUP QUESTIONS)

A. RESPONDENT

B. SPOUSE

C. CHILDREN _____

GO TO V27

V26b. Did you get a degree?

1. YES 5. NO -->GO TO V27

V26c. What degree did you earn?
(What was the highest?)

1. ASSOCIATES 2. BACHELORS

3. MA/MBA 4. PHD 5. MD 6. LAW

7. OTHER: _____

V26d. Did your (husband/wife) get a degree?

1. YES 5. NO -->GO TO V27

V26e. What degree did (he/she) earn?
(What was the highest?)

1. ASSOCIATES 2. BACHELORS

3. MA/MBA 4. PHD 5. MD 6. LAW

7. OTHER: _____

V27. How much in total did you (and your [husband/wife]) personally have to pay for all these college or trade school expenses since 1983, including any loans you may have taken out?

\$ _____

NOTHING

V28. Since 1983 did you (or your [husband/wife]) pay any (other) tuition expenses for a private or parochial school for anyone?

 1. YES

 5. NO --> GO TO V29

V28a. In total, how much did you pay for private or parochial school tuition expenses during that period?

\$ _____

V29. Now I have some questions about the past three years. During the past three years, have you (or anyone in your family living here) purchased any kind of vehicle---car, truck, van or motorhome, boat or airplane, not including vehicles owned by a business or any leased vehicles?

 1. YES

 5. NO -->GO TO V30

V29a. About how much in total was the purchase price of these vehicles?

\$ _____

V30. During the past three years have you (or anyone in your family living here) made purchases totaling \$3,000 or more for any furniture, appliances, or recreation items?

 1. YES

 5. NO -->GO TO V31

V30a. About how much did these items cost in total?

\$ _____

V31. During the past three years did you (or anyone in your family living here) have a major illness or disability which required hospitalization or cost more than \$1,000?

 1. YES

 5. NO --> NEXT PAGE, V32

V31a. Not including the costs paid for by insurance, during the past three years how much in total did you (or anyone in your family living here) personally have to pay for expenses related to such illnesses or disabilities?

\$ _____

 NOTHING

V32. During the past three years, did you (or anyone in your family living here) have any unusually large expenses that you paid for yourself, such as a child's marriage, a lawsuit, or any other large expenses you have not mentioned already?

1. YES

5. NO --> GO TO V33

V32a. What was that expense for? (Were there any other unusually large expenses?)

V32b. How much did it cost you in total (for all these expenses)?

\$ _____

V33. During the past three years, did you (or anyone in your family living here) receive any unusually large amounts of money or property, such as an insurance or legal award, winning the lottery, or any other unusually large financial benefits that you have not already mentioned?

1. YES

5. NO -->NEXT PAGE, SECTION Y

V33a. From what source did you receive this money or property? (Were there any other sources?)

V33b. How much did you receive in total from (this/all these) source(s)?

\$ _____

SECTION Y: RESPONDENT DEMOGRAPHICS

Y1. Now I'd like to ask some questions about your family living elsewhere. Altogether, including children from previous marriages and adopted children, how many sons and daughters do you (or your [husband/wife]) have who do not live with you?

_____ # CHILDREN 96. NONE --->GO TO Y2

↓

Y1a. How many of them are 25 or older?

_____ # 25 or OLDER 95. ALL OF THEM 96. NONE

GO TO Y2

Y1b. And how many of them are less than 18 years old?

_____ # LESS THAN 18 95. ALL OF THEM 96. NONE

Y2. How many living brothers and sisters do you have?

_____ # BROTHERS/SISTERS 96. NONE -->GO TO Y3

↓

Y2a. How many are older than you?

_____ # OLDER 95. ALL 96. NONE

Y3. Now I'd like to ask about your parents. Is your mother still living?

1. YES

5. NO

8. DK



GO TO Y3b

Y3a. What is her age?

_____ AGE

Y3b. Is your father still living?

1. YES

5. NO

8. DK



GO TO Y4

Y3c. What is his age?

_____ AGE

Y4. Are you American Indian, Asian, Hispanic, black, white, or another race?

1. AM. INDIAN/
ESKIMO/ALEUT

2. ASIAN

3. HISPANIC

4. BLACK

5. WHITE

7. OTHER:

Y5. Now I'd like to ask you about your health; would you say your health is excellent, good, fair, or poor?

- | | | | | |
|--------------|---------|---------|---------|-------|
| 1. EXCELLENT | 2. GOOD | 3. FAIR | 4. POOR | 8. DK |
|--------------|---------|---------|---------|-------|

Y6. INTERVIEWER CHECKPOINT:

SEE HHL UPDATE, "DATE OF LAST IW"

1. R WAS INTERVIEWED IN '86

2. ALL OTHERS -->TURN TO P. 133, YY1

Y6a. INTERVIEWER CHECKPOINT: CURRENT MARITAL STATUS

SEE HHL UPDATE, ITEM #1

1. MARRIED; INCLUDING SPOUSE AWAY IN SERVICE	2. PARTNER TURN TO P. 127, Y9	3. SEPARATED TURN TO P. 130, Y10	4. DIVORCED TURN TO P. 131, Y11	5. WIDOWED TURN TO P. 132, Y12	6. NEVER MARRIED TURN TO P. 143, Y25
---	-------------------------------------	--	---------------------------------------	--------------------------------------	---

Y6b. INTERVIEWER CHECKPOINT

SEE HHL UPDATE, ITEM #2

1. R MARRIED TO SAME PERSON AS IN 1986-->TURN TO P. 142, Y17

2. R MARRIED TO DIFFERENT PERSON THAN IN 1986

3. ALL OTHERS --> TURN TO P. 125, Y8

NEXT PAGE, Y7

CURRENTLY MARRIED TO DIFFERENT PERSON THAN IN 1986

Y7. In what month and year did your current marriage begin?

MONTH / YEAR

Y7a. We are interested in how changes in marital status affect people's financial well-being. At the time of your marriage, about how much did your (husband/wife) have in assets?

\$ _____ NONE

Y7b. At that time, about how much did (he/she) have in debts?

\$ _____ NONE

Y7c. NO QUESTION

Y7d. NO QUESTION

Y7e. In what month and year did your previous marriage end?

MONTH / YEAR

Y7f. Did that marriage end in divorce or were you widowed?

5. WIDOWED

4. DIVORCED

Y7g. At the time of your (husband's/wife's) death, were any assets given to charities or to anyone not living with you now?

1. YES 5. NO -->NEXT PAGE, Y7j

Y7h. About how much was that?

\$ _____
NEXT PAGE, Y7j

Y7m. At the time of your divorce, was there a division of assets?

1. YES 5. NO -->NEXT PAGE, Y7q

Y7n. What was the total dollar value of the assets that you retained, including your share of the financial assets, the home and other real estate and any other property that you received?

\$ _____
NEXT PAGE, Y7p

CURRENTLY MARRIED TO DIFFERENT PERSON THAN IN '86

Y7j. Did you receive any settlements from life insurance on your (husband/wife)?

- 1. YES
- 5. NO

↓
TURN TO
P. 141, Y13

Y7k. About how much was that?

\$ _____

Y7p. What was the total dollar value of the assets that your (ex-husband/ex-wife) retained?

\$ _____

Y7q. Were you required to pay alimony, were you supposed to receive alimony, or was no alimony involved in the settlement?

- 1. PAY ALIM
- 2. RECEIVE ALIM
- 5. NO ALIMONY INVOLVED

Y7r. Did you receive custody of your children, did your former (husband/wife) receive custody, do you have joint custody, or were no children involved in the settlement?

- 1. R CUST
- 2. SP CUST
- 3. JOINT CUST
- 5. NO CHILD

TURN TO
P. 141, Y13

Y7s. Were you required to pay child support, were you supposed to receive child support, or was child support not involved in the settlement?

- 1. PAY
- 2. RECEIVE
- 5. NO SUPPORT

—>TURN TO P. 141, Y13<—

CURRENTLY MARRIED: NO SPOUSE PRESENT IN '86

Y8. In what month and year were you and your (husband/wife) married?

_____ MONTH / YEAR

Y8a. We are interested in how changes in marital status affect people's financial well-being. At the time of your marriage, about how much did your (husband/wife) have in assets?

\$ _____ NONE

Y8b. At this time, about how much did (he/she) have in debts?

\$ _____ NONE

Y8c. Altogether, how many times have you been married, including your current marriage?

1. ONE

2. TWO

3. THREE

4. 4 OR MORE

TURN TO
P. 141, Y13



Y8d. In what month and year did your previous marriage end? _____ MONTH/YEAR

Y8e. INTERVIEWER CHECKPOINT

SEE Y8d

1. LAST MARRIAGE ENDED BEFORE '83 -->TURN TO P. 141, Y13

2. ALL OTHERS

Y8f. Did that marriage end in divorce or were you widowed?

5. WIDOWED

4. DIVORCED

Y8g. At the time of your (husband's/wife's) death, were any assets given to charities or to anyone not living with you now?

1. YES 5. NO -->NEXT PAGE, Y8j

Y8h. About how much was that?

\$ _____
NEXT PAGE, Y8j

Y8m. At the time of the divorce, was there a division of assets?

1. YES 5. NO --> NEXT PAGE, Y8q

Y8n. What was the total dollar value of the assets that you retained, including your share of the financial assets, the home and other real estate and any other property that you received?

\$ _____
NEXT PAGE, Y8p

CURRENTLY MARRIED: NO SPOUSE PRESENT IN 1986

Y8j. Did you receive any settlements from life insurance on your (husband/wife)?

- 1. YES
- 5. NO

↓ TURN TO P. 141, Y13

Y8k. About how much was that?

\$ _____

Y8p. What was the total dollar value of the assets that your (ex-husband/ex-wife) retained?

\$ _____

Y8q. Were you required to pay alimony, were you supposed to receive alimony, or was no alimony involved in the settlement?

- 1. PAY ALIM
- 2. RECEIVE ALIM
- 5. NO ALIMONY INVOLVED

Y8r. Did you receive custody of your children, did your former (husband/wife) receive custody, do you have joint custody, or were no children involved in the settlement?

- 1. R CUST
- 2. SP CUST
- 3. JOINT CUST
- 5. NO CHILD

TURN TO P. 141, Y13

Y8s. Were you required to pay child support, were you supposed to receive child support, or was child support not involved in the settlement?

- 1. PAY
- 2. RECEIVE
- 5. NO SUPPORT

>TURN TO P. 141, Y13<

Y9. In what month and year did you start living with your partner?

 MONTH / YEAR

Y9a. INTERVIEWER CHECKPOINT, SEE Y9

1. R STARTED LIVING WITH PARTNER 1983 OR LATER
 2. ALL OTHERS-->TURN TO P. 141, Y13

Y9b. We are interested in how changes in living situations affect peoples' financial well-being. At the time you began living together, about how much did your partner have in assets?
 \$ _____ NONE

Y9c. At this time, about how much did (he/she) have in debts?
 \$ _____ NONE

Y9d. Have you ever been married? (to someone else?)
 1. YES 5. NO --->TURN TO P. 141, Y13

Y9j. When did your (last) marriage end? _____ 95. CURRENTLY SEPARATED
 MONTH / YEAR

Y9k. INTERVIEWER CHECKPOINT GO TO Y9n

SEE Y9j

1. MARRIAGE ENDED 1983 OR LATER
 2. ALL OTHERS -----> TURN TO P. 141, Y13

Y9m. Were you widowed or divorced, or are you separated?
 5. WIDOWED 4. DIVORCED 3. SEPARATED
 TURN TO P. 129, Y9y NEXT PAGE, Y9s

CURRENTLY LIVING WITH PARTNER: SEPARATED SINCE 1983

Y9n. Do you receive support from your (husband/wife), do you pay support, or is there no support involved?

1. RECEIVE SUPPORT 2. NO SUPPORT INVOLVED 3. PAY SUPPORT

Y9p. How much do you receive?
 \$ _____ PER _____

Y9q. How much do you pay?
 \$ _____ PER _____

Y9r. Are the assets and debts that you've told me about in this interview owned mainly by you, are they owned jointly with your (husband/wife), or what?
 1. OWNED BY R 2. OWNED JOINTLY 7. OTHER _____
 >TURN TO P. 141, Y13<

CURRENTLY LIVING WITH PARTNER, DIVORCED SINCE 1983

Y9s. At the time of your divorce, was there a division of assets or property?

1. YES 5. NO --> GO TO Y9v



Y9t. What was the total dollar value of the assets that you retained, including your share of the financial assets, the home and other real estate and any other property that you received?

\$ _____

Y9u. What was the total dollar value of the assets that your (ex-husband/ ex-wife) retained?

\$ _____

Y9v. Were you required to pay alimony, were you supposed to receive alimony, or was no alimony involved in the settlement?

1. PAY ALIMONY 2. RECEIVE ALIMONY 5. NO ALIMONY INVOLVED

Y9w. Did you receive custody of your children, did your former (husband/wife) receive custody, do you have joint custody, or were no children involved in the settlement?

1. R HAS CUSTODY 2. SPOUSE HAS CUSTODY 3. JOINT 5. NO CHILDREN INV

TURN TO P. 141, Y13



Y9x. Were you required to pay child support, were you supposed to receive child support, or was child support not involved in the settlement?

1. PAY SUPPORT 2. RECEIVE SUPPORT 5. NO CHILD SUPPORT

>TURN TO P. 141, Y13<

CURRENTLY LIVING WITH PARTNER, WIDOWED SINCE 1983

Y9y. At the time of your (husband's/wife's) death, were any assets given to charities or to anyone not living with you now?

 1. YES 5. NO --> GO TO Y9aa

Y9z. About how much was that?

\$ _____

Y9aa. Did you receive any settlements from life insurance on your (husband/wife)?

 1. YES 5. NO --> TURN TO P. 141, Y13

Y9bb. About how much was that?

\$ _____
TURN TO P. 141, Y13

CURRENTLY SEPARATED

Y10. In what month and year were you separated?

_____ MONTH / YEAR

Y10a. In what month and year did that marriage begin?

_____ MONTH / YEAR

Y10b. INTERVIEWER CHECKPOINT, SEE Y10a

- 1. LAST MARRIAGE BEGAN 1983 OR LATER
- 2. ALL OTHERS --> GO TO Y10e

Y10c. We are interested in how changes in marital status affect peoples' financial well-being. At the time of your marriage, about how much how much did your (husband/wife) have in assets?

\$ _____ NONE

Y10d. At this time, about how much did (he/she) have in debts?

\$ _____ NONE

Y10e. Do you receive support from your (husband/wife), do you pay support, or is there no support involved?

1. RECEIVE SUPPORT

2. NO SUPPORT INVOLVED

3. PAY SUPPORT

↓
Y10f. How much do you receive?

\$ _____ PER _____

↓
Y10g. How much do you pay?

\$ _____ PER _____

Y10h. Are the assets and debts that you've told me about in this interview owned mainly by you, are they owned jointly with your (husband/wife), or what?

1. OWNED BY R

2. OWNED JOINTLY

7. OTHER _____

TURN TO P. 143, Y25

CURRENTLY DIVORCED

Y11. In what month and year were you divorced?

_____ MONTH / YEAR

Y11a. In what month and year did that marriage begin?

_____ MONTH / YEAR

Y11b. INTERVIEWER CHECKPOINT, SEE Y11

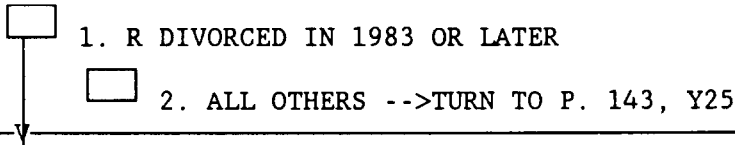

Y11c. At the time of your divorce, was there a division of assets or property?

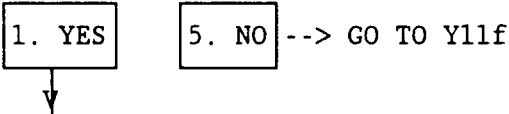

Y11d. What was the total dollar value of the assets that you retained, including your share of the financial assets, the home and other real estate and any other property that you received?

\$ _____

Y11e. What was the total dollar value of the assets that your (ex-husband/ ex-wife) kept or retained?

\$ _____

Y11f. Were you required to pay alimony, were you supposed to receive alimony, or was no alimony involved in the settlement?

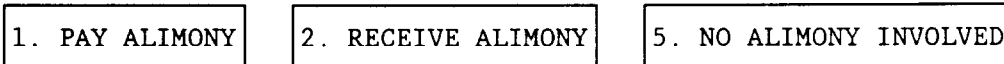

Y11g. Did you receive custody of your children, did your former (husband/wife) receive custody, do you have joint custody, or were no children involved in the settlement?

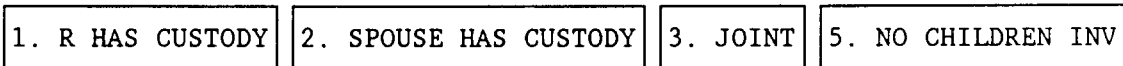

TURN TO P. 143, Y25

Y11h. Were you required to pay child support, were you supposed to receive child support, or was child support not involved in the settlement?

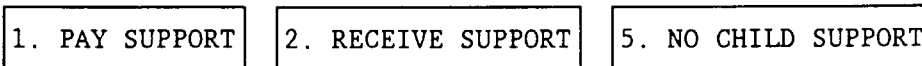

TURN TO P. 143, Y25

CURRENTLY WIDOWED

Y12. In what month and year were you widowed?

MONTH / YEAR

Y12a. In what month and year did that marriage begin?

MONTH / YEAR

Y12b. INTERVIEWER CHECKPOINT, SEE Y12

1. R WIDOWED 1983 OR LATER

2. ALL OTHERS -->TURN TO P. 143, Y25

Y12c. At the time of your (husband's/wife's) death, were any assets given to charities or to anyone not living with you now?

1. YES

5. NO

--> GO TO Y12e

Y12d. About how much was that? \$ _____

Y12e. Did you receive any settlements from life insurance on your (husband/wife)?

1. YES

5. NO

-->TURN TO P. 143, Y25

Y12f. About how much was that?

\$ _____

TURN TO P. 143, Y25

SECTION YY: RESPONDENT DEMOGRAPHICS
(FOR R'S NOT INTERVIEWED IN '86)

YY1. INTERVIEWER CHECKPOINT:

SEE HHL UPDATE, ITEM #1

1. MARRIED; INCLUDING SPOUSE AWAY IN SERVICE	2. PARTNER	3. SEPARATED	4. DIVORCED	5. WIDOWED	6. NEVER MARRIED
	TURN TO P. 137, YY5	NEXT PAGE, YY2	TURN TO P. 135, YY3	TURN TO P. 136, YY4	TURN TO P. 143, Y25



CURRENTLY MARRIED

YY1a. In what month and year were you (last) married?

MONTH / YEAR

YY1b. Is this your first marriage or have you been married before?

1. FIRST MARRIAGE	5. MARRIED BEFORE
-------------------	-------------------

TURN TO P. 141, Y13

YY1c. Altogether, how many times have you been married, including your current marriage?

2. TWO	3. THREE	4. 4 OR MORE
--------	----------	--------------

TURN TO P. 137, YY6

YY1d. Did any of these marriages end by your being widowed?

1. YES	5. NO --->TURN TO P. 138, YY7
--------	-------------------------------

YY1e. How many?

_____ # TIMES WIDOWED

TURN TO P. 138, YY7

CURRENTLY SEPARATED

YY2. In what month and year were you separated?

MONTH / YEAR

YY2a. In what month and year did this marriage begin?

MONTH / YEAR

YY2b. Do you receive support from your (husband/wife), do you pay support, or is there no support involved?

1. RECEIVE SUPPORT

2. NO SUPPORT INVOLVED

3. PAY SUPPORT

YY2c. How much do you receive?

\$ _____ PER _____

YY2d. How much do you pay?

\$ _____ PER _____

YY2e. Are the assets and debts that you've told me about in this interview owned mainly by you, are they owned jointly with your (husband/wife), or what?

1. OWNED BY R

2. OWNED JOINTLY

7. OTHER _____

YY2f. Is this your first marriage or have you been married before?

1. FIRST MARRIAGE

5. MARRIED BEFORE

TURN TO P. 143, Y25

YY2g. Altogether, how many times have you been married, including your current marriage?

2. TWO

3. THREE

4. 4 OR MORE

TURN TO P. 137, YY6

YY2h. Did any of these marriages end by your being widowed?

1. YES

5. NO --->TURN TO P. 138, YY7

YY2j. How many?

_____ # TIMES WIDOWED

TURN TO P. 138, YY7

CURRENTLY DIVORCED

YY3. In what month and year were you (last) divorced?

MONTH / YEAR

YY3a. In what month and year did that marriage begin?

MONTH / YEAR

YY3b. Was that your first marriage or had you been married before?

1. FIRST MARRIAGE

5. MARRIED BEFORE

GO TO YY3h



YY3c. Altogether, how many times have you been married?

2. TWO

3. THREE

4. FOUR OR MORE

YY3d. Did any of these marriages end by your being widowed?

1. YES

5. NO --->GO TO YY3f



YY3e. How many? _____ # TIMES WIDOWED

YY3f. At what age were you first married?

AT _____ YEARS OLD OR 19 _____

YY3g. For about how many years in total have you been married? (ACCEPT RANGE)

_____ # YEARS

YY3h. INTERVIEWER CHECKPOINT

SEE YY3

1. R DIVORCED 1983 OR LATER-->TURN TO P. 139, YY7f

2. ALL OTHERS--> TURN TO P. 143, Y25

CURRENTLY WIDOWED

YY4. In what month and year were you (last) widowed?

MONTH / YEAR

YY4a. In what month and year did that marriage begin?

MONTH / YEAR

YY4b. Was that your first marriage or had you been married before?

1. FIRST MARRIAGE

5. MARRIED BEFORE

GO TO YY4h



YY4c. Altogether, how many times have you been married?

2. TWO

3. THREE

4. FOUR OR MORE

YY4d. Did any of these marriages end in divorce?

1. YES

5. NO

--->GO TO YY4f



YY4e. How many? _____ # TIMES DIVORCED

YY4f. At what age were you first married?

AT _____ YEARS OLD OR 19 _____

YY4g. For about how many years in total have you been married? (ACCEPT RANGE)

_____ # YEARS

YY4h. INTERVIEWER CHECKPOINT

SEE YY4

1. R WIDOWED 1983 OR LATER-->TURN TO P. 140, YY7n

2. ALL OTHERS--> TURN TO P. 143, Y25

PARTNER

YY5. In what month and year did you start living with your partner?

_____ MONTH / YEAR

YY5a. Have you ever been married? (to someone else?)

1. YES 5. NO --->TURN TO P. 141, Y13

YY5b. Altogether, how many times have you been married? (LEGAL MARRIAGES)

1. ONE 2. TWO 3. THREE 4 OR MORE

GO TO YY6

YY5c. Did any of these marriages end in divorce?

1. YES 5. NO --->NEXT PAGE, YY7

YY5d. How many? _____ # TIMES DIVORCED

NEXT PAGE, YY7

TWO MARRIAGES (INCLUDING CURRENT SPOUSE OR PARTNER)

YY6. When did your (first) marriage begin?

19 _____ OR _____ YEARS AGO

YY6a. And when did that marriage end?

19 _____ OR _____ YEARS AGO

95. CURRENTLY SEPARATED ->TURN TO P. 140, YY7s

YY6b. Did that marriage end in divorce or were you widowed?

4. DIVORCE 5. WIDOWED 3. SEPARATED ->TURN TO P. 140, YY7s

YY6c. IWER CHECKPOINT---SEE YY6a

1. DIVORCED IN 1983 OR LATER
TURN TO P. 139, YY7f
2. ALL OTHERS-->TURN TO
P. 140, YY8

YY6d. IWER CHECKPOINT---SEE YY6a

1. WIDOWED IN 1983 OR LATER
TURN TO P. 140, YY7n
2. ALL OTHERS-->TURN TO
P. 140, YY8

YY7. At what age were you first married?

AT _____ YEARS OLD OR 19 _____

YY7a. For about how many years in total have you been married (including your current marriage)?
(ACCEPT RANGE.) _____ # YEARS



YY7b. INTERVIEWER CHECKPOINT

SEE HHL UPDATE, ITEMS #1 AND #2

- 1. R IS MARRIED TO OR LIVING WITH DIFFERENT PERSON THAN IN 1983 (BOX 2 CHECKED AT ITEM #2)
- 2. R IS SEPARATED (BOX 2 CHECKED AT ITEM #1)
- 3. ALL OTHERS--> TURN TO P. 140, YY8



YY7c. In what month and year did your (last) previous marriage end?

_____/_____
MONTH YEAR

95. CURRENTLY SEPARATED ->TURN TO P. 140, YY7s

YY7d. Did that marriage end in divorce or were you widowed?

4. DIVORCE

5. WIDOWED

3. SEPARATED ->TURN TO P. 140, YY7s



NEXT PAGE, YY7f



TURN TO P. 140, YY7n

R WAS DIVORCED IN 83 OR LATER

YY7f. At the time of your (last) divorce, was there a division of assets?

1. YES

5. NO -->GO TO YY7j

YY7g. What was the total dollar value of the assets that you retained, including your share of the financial assets, the home and other real estate and any other property that you received?

\$ _____

YY7h. What was the total dollar value of the assets that your (ex-husband/ex-wife) retained?

\$ _____

YY7j. Were you required to pay alimony, were you supposed to receive alimony, or was no alimony involved in the settlement?

1. PAY ALIMONY

2. RECEIVE ALIMONY

5. NO ALIMONY INVOLVED

YY7k. Did you receive custody of your children, did your former (husband /wife) receive custody, do you have joint custody, or were no children involved in the settlement?

1. R CUST

2. SP CUST

3. JOINT CUST

5. NO CHILD

NEXT PAGE, YY8

YY7m. Were you required to pay child support, were you supposed to receive child support, or was child support not involved in the settlement?

1. PAY

2. RECEIVE

5. NO SUPPORT

NEXT PAGE, YY8

Y13. Now I'd like to ask you some questions about your (husband's/wife's/partner's) background. What is the highest grade of school or year of college (he/she) completed?

GRADES OF SCHOOL

00	01	02	03	04	05	06
06	07	08	09	10	11	12



Y13a. Did (he/she) get a high school diploma or pass a high school equivalency test?

1. YES

5. NO

Y13b. Since completing (his/her) formal education, has (he/she) had on-the-job training or other vocational training lasting 100 hours or more?

1. YES

5. NO

COLLEGE

13	14	15	16	17+
----	----	----	----	-----



Y13c. Did (he/she) get a college degree?

1. YES

5. NO

GO TO Y14



Y13d. What is the highest degree (he/she) earned?

1. ASSOCIATES

2. BACHELORS

3. MA/MBA

4. PHD

5. MD

6. LAW

7. OTHER:

Y14. Now I have a few questions about past jobs your (husband/wife/partner) may have had. During the past 36 months, that is the last three years, has (he/she) done any work for pay?

1. YES

5. NO -->NEXT PAGE, Y15



Y14a. How many months over this period has (he/she) worked full-time?

_____ # MONTHS

96. NONE

95. ALL -->NEXT PAGE, Y15



Y14b. And for how many months over this period has (he/she) only worked part-time?

_____ # MONTHS

96. NONE

95. ALL

Y20. Is your (husband's/wife's/partner's) father still living?

1. YES

5. NO

8. DK

Y20a. What is his age?

GO TO Y21

_____ AGE

Y21. Now I'd like to ask you some questions about your family's health; first would you say your (husband's/wife's/partner's) health in general is excellent, good, fair, or poor?

1. EXCELLENT

2. GOOD

3. FAIR

4. POOR

8. DK

Y22-Y24. NO QUESTIONS

Y25. INTERVIEWER CHECKPOINT

SEE HHL UPDATE, COLUMN k AND ITEM #9a

1. 1 OR MORE ADULTS WITH INDEPENDENT FINANCES (COL. K MARKED YES)

2. R LIVES ALONE (YES AT ITEM 9a) -----> NEXT PAGE, Y26

3. ALL OTHERS----->GO TO Y25a

READ: For the rest of the questions in the interview, please include the adults in your household who have independent finances.

Y25a. Do you or anyone in your family living here (including those with independent finances) have any persistent or chronic health conditions or problems?

1. YES

5. NO --> TURN TO P. 145, Y29

Y25b. Which family members have these health conditions or problems and what are they? (Any others?) (LIST MEMBERS BY RELATION TO R)

Y25c. FAMILY MEMBER

Y25d. AGE

Y25e. HEALTH CONDITIONS

1.	_____	_____	_____
2.	_____	_____	_____
3.	_____	_____	_____
4.	_____	_____	_____

TURN TO P. 145, Y29

R LIVES ALONE

Y26. Do you have any persistent or chronic health conditions or problems?

1. YES

5. NO --> GO TO Y27

Y26a. What are these health conditions or problems? (Any others?)

Y27. Are you currently eligible to receive benefits from any government health insurance programs, such as Medicare, Medicaid, or CHAMPUS, VA, or other military programs?

1. YES

5. NO --> GO TO Y28

Y27a. Which program is that? (Anything else?) (CHECK ALL THAT APPLY.)
 (IWER: ONLY PERSONS 65 OR OLDER SHOULD BE ELIGIBLE FOR MEDICARE. ONLY POOR PERSONS SHOULD BE ELIGIBLE FOR MEDICAID. CHAMPUS IS FOR ACTIVE MILITARY.)

A. MEDICARE

B. MEDICAID

C. VA/CHAMPUS

D. OTHER _____

Y27b. Do you have any other type of health coverage such as employer plans, or Blue Cross-Blue Shield, or a Health Maintenance Organization?

1. YES

5. NO

GO TO Y28a TURN TO P. 151, Y41

Y28. Do you have any type of health coverage such as employer plans or Blue Cross-Blue Shield, or a Health Maintenance Organization?

1. YES

5. NO --> TURN TO P. 147, Y32

Y28a. Is this coverage obtained through your employer or former employer, a union, through direct payments to an insurance company, or what? (CHECK ALL THAT APPLY.)

A. EMPLOYER

B. FORMER EMPLOYER

C. UNION

D. DIRECT PAYMENT

E. OTHER: _____

Y28b. How is this coverage paid for -- by you, by an employer, by you and an employer, by a relative, or what? (CHECK ALL THAT APPLY.)

A. R

B. EMPLOYER

C. RELATIVE

D. FORMER EMPLOYER

E. OTHER: _____

TURN TO P. 151, Y41

Y29. Are you or anyone in your family living here (including family members with independent finances) currently eligible to receive benefits from any government health insurance programs, such as Medicare, Medicaid, or CHAMPUS, VA, or other military programs?

1. YES

5. NO --> GO TO Y30



Y29a. Which program is that? (Anything else?) (CHECK ALL THAT APPLY.)
 (IWER: ONLY PERSONS 65 OR OLDER SHOULD BE ELIGIBLE FOR MEDICARE. ONLY POOR PERSONS SHOULD BE ELIGIBLE FOR MEDICAID. CHAMPUS IS FOR ACTIVE MILITARY.)

A. MEDICARE

B. MEDICAID

C. VA/CHAMPUS

D. OTHER _____

Y29b. Is everyone living here covered by (this/one of these) program(s)?

1. YES

5. NO --> GO TO Y29d



Y29c. Do you or anyone living here have any other type of health coverage such as employer plans, or Blue Cross-Blue Shield, or a Health Maintenance Organization?

1. YES

5. NO

NEXT PAGE Y31

TURN TO P. 147, Y33

Y29d. Who is not covered? (Anyone else?) (CHECK ALL THAT APPLY.)

A. R

B. SPOUSE

C. CHILD(REN)
UNDER 18

D. CHILD(REN) 18 AND OVER

E. FATHER
(IN-LAW)

F. MOTHER
(IN-LAW)

G. OTHER: _____

Y30. Do you or anyone living here have any (other) type of health coverage such as employer plans, or Blue Cross-Blue Shield, or a Health Maintenance Organization?

1. YES

5. NO

NEXT PAGE, Y31

TURN TO P. 147, Y32

Y31. Is this coverage obtained through your employer, former employer, or union, (your [husband's/wife's/partner's] employer, former employer, or union,) through direct payments to an insurance company, or what? (CHECK ALL THAT APPLY.)

A. R'S EMPLOYER	B. R'S FORMER EMPLOYER	C. R'S UNION
D. S'S EMPLOYER	E. S'S FORMER EMPLOYER	F. S'S UNION
G. DIRECT PAYMENT	H. OTHER: _____	

Y31a. How is this coverage paid for -- by you or someone in your family living here, by an employer, by you and an employer, by a relative not living here, or what? (CHECK ALL THAT APPLY.)

A. R/FAMILY	B. EMPLOYER	C. RELATIVE	D. FORMER EMPLOYER	E. OTHER: _____
-------------	-------------	-------------	--------------------	-----------------

Y31b. Is everyone in your family living here covered by at least one of these private health programs?

1. YES	5. NO
--------	-------

NEXT PAGE, Y33



Y31c. Who is not covered (including those with independent finances)? (Anyone else?) (CHECK ALL THAT APPLY.)

A. R	B. SPOUSE	C. CHILD(REN) UNDER 18	D. CHILD(REN) 18 AND OVER	E. FATHER (IN-LAW)	F. MOTHER (IN-LAW)
G. OTHER: _____					

Y32. I will read a list of reasons why some people don't have health insurance. For each, please tell me whether it describes why (you/some members of your family living here) are not covered.

	YES (1)	NO (5)
A. TOO EXPENSIVE, CAN'T AFFORD HEALTH INSURANCE		
B. CAN'T GET INSURANCE BECAUSE OF POOR HEALTH, AGE, OR ILLNESS		
C. DON'T BELIEVE IN HEALTH INSURANCE		
D. NOT MUCH SICKNESS IN THE FAMILY; WE HAVEN'T NEEDED INSURANCE		
E. DISSATISFIED WITH PREVIOUS INSURANCE		
F. JOB LAYOFF OR JOB LOSS		
G. OTHER: _____		

Y32a. (IWER: IF MORE THAN 1 "YES" ANSWER, ASK:) Which of these is the most important reason?

(Letter) _____

Y33. INTERVIEWER CHECKPOINT

SEE HHL UPDATE, COLUMN K

- 1. 1 OR MORE ADULTS WITH INDEPENDENT FINANCES (COL. k MARKED "YES")
- 2. ALL OTHERS----->TURN TO P. 151, Y41

Y34. I'd like to ask some questions just about the other adults 22 and over who live with you (and your family) but have independent finances. (Does he/Does she/Do any of these other adults) receive any income from wages or salaries?

1. YES

5. NO

8. DON'T KNOW

NEXT PAGE, Y35

Y34a. Roughly how much total income did (he/she/they) have from wages and salaries in 1988 before taxes and deductions? (ACCEPT RANGE.)

\$ _____

DON'T KNOW

-->NEXT PAGE, Y35

Y34b. Did you include this amount in the income you told me about earlier in this interview? (IF R ONLY TOLD ABOUT PART, MAKE NOTE.)

1. YES

5. NO

Y35. (Does he/Does she/Do they) receive income from any other sources (such as social security, a pension, disability payments, public assistance, or income from a business or other assets)?

1. YES

5. NO

8. DON'T KNOW



GO TO Y36

Y35a. What other sources of income (does he/does she/do they) have?
(CHECK ALL THAT APPLY.)

A. SOCIAL SECURITY

B. PENSIONS

C. DISABILITY

D. PUBLIC ASSISTANCE

E. INTEREST INCOME

F. DIVIDENDS

G. BUSINESS

H. REAL ESTATE

J. OTHER: _____

Y35b. Roughly how much total income did (he/she/they) have from (all these/this) source(s) in 1988 before taxes and deductions?

\$ _____

DON'T KNOW --->GO TO Y36

Y35c. Did you include this amount in the income you told me about earlier in this interview? (IF R ONLY TOLD ABOUT PART, MAKE NOTE.)

1. YES

5. NO

Y36. (Does he/Does she/Do any of them) have any cars or other vehicles?

1. YES

5. NO --->NEXT PAGE Y37



Y36a. Roughly, how much (is this/are these) vehicle(s) worth in today's prices? (ACCEPT RANGE.)

\$ _____

DON'T KNOW --->NEXT PAGE, Y37

Y36b. Did you include (this/these) vehicle(s) in the ones you told me about earlier in this interview? (IF R ONLY TOLD ABOUT PART, MAKE NOTE.)

1. YES

5. NO

Y37. (Does he/Does she/Do they) have any bank accounts, savings accounts, or savings bonds?

1. YES
 5. NO
 8. DON'T KNOW

GO TO Y38

Y37a. Roughly how much in total (does he/does she/do they) have in bank accounts, savings accounts, or savings bonds? (ACCEPT RANGE.)

\$ _____ DON'T KNOW --->GO TO Y38

Y37b. Did you include this amount when you told me about these items earlier in this interview? (IF R ONLY TOLD ABOUT PART, MAKE NOTE.)

1. YES
 5. NO

Y38. (Does he/Does she/Do they) have any other assets (such as stocks, bonds, a business, or any properties, including any part of the [house/apartment] you live in)?

1. YES
 5. NO
 8. DON'T KNOW

NEXT PAGE, Y40

Y38a. What other kinds of assets (does he/does she/do they) have? (CHECK ALL THAT APPLY.)

A. R'S HOME B. STOCKS C. BOND D. MUTUAL FUNDS
 E. MONEY MARKET FUNDS F. BUSINESS G. OTHER REAL ESTATE

H. OTHER: _____

Y38b. Roughly how much in total (does he/does she/do they) have in (all these/this) asset(s)? (ACCEPT RANGE.)

\$ _____ DON'T KNOW --->NEXT PAGE, Y39

Y38c. Did you include this amount in the assets you told me about earlier in this interview? (IF R ONLY TOLD ABOUT PART, MAKE NOTE.)

1. YES
 5. NO

NEXT PAGE, Y40

NEXT PAGE, Y39

Y39. INTERVIEWER CHECKPOINT

SEE P. 149, Y38a

1. "R'S HOME" BOX A MARKED IN Y38a

2. ALL OTHERS----->GO TO Y40



Y39a. What share of this home (does he/does she/do they) own?

_____ PERCENT

Y39b. What is the present value of this home? I mean, about what would it bring if it were sold today?

\$ _____

Y39c. What is the amount still owed on all the mortgages, land contracts and loans on the home? (ACCEPT RANGE.)

\$ _____

Y40. Not including any debts (he/she/they) owe(s) you (or your [husband/wife]), (does he/does she/do they) have any debts? (IF R ASKS: DO NOT INCLUDE MORTGAGE ON R'S HOME.)



NEXT PAGE, Y41

Y40a. Roughly how much in total are (his/her/their) debts?

\$ _____

----->NEXT PAGE, Y41

Y40b. Did you include these debts when you told me about the household debts earlier in this interview? (IF R ONLY TOLD ABOUT PART, MAKE NOTE.)

Y41. That finishes the actual interview. Is there anything you would like to add to any of the subjects we've discussed?

Y41a. EXACT TIME NOW: _____

IWER: COMPLETE BOXES Y42 AND Y43

Y42. END OF IW REFERENCE: RESPONDENT'S EMPLOYMENT/PENSION INFORMATION

<input type="checkbox"/>	1. R IS COVERED BY PENSION ON CURRENT JOB (1 OR MORE PLANS AT R18, P. 82)
<input type="checkbox"/>	2. ALL OTHERS

Y43. END OF IW REFERENCE: SPOUSE EMPLOYMENT/PENSION INFORMATION

<input type="checkbox"/>	3. R IS NOT MARRIED
<input type="checkbox"/>	4. S IS COVERED BY PENSION ON CURRENT JOB (1 OR MORE PLANS AT S18, P. 6 IN THE SUPPLEMENTAL BOOKLET)
<input type="checkbox"/>	5. ALL OTHERS

Y44. INTERVIEWER: TURN TO COVERSHEET, P. 2, Z1

NOTE: THE NUMBERS IN THE BOXES AT Z1 AND Z4 IN THE COVERSHEET MATCH THE BOXES CHECKED IN Y42 AND Y43 ABOVE.

SECTION ZZ: INTERVIEWER OBSERVATIONS

ZZ1. RELATIONSHIP OF R TO INFORMANT:

1. R IS INFORMANT

7. OTHER: R IS _____
OF INFORMANT

ZZ2. TYPE OF STRUCTURE IN WHICH FAMILY LIVES:

00. IW NOT CONDUCTED AT R'S HOME

TURN TO
-->P. 154,
ZZ10

01. TRAILER; MOBILE HOME

07. APARTMENT HOUSE (4 OR FEWER UNITS)

02. DETACHED SINGLE FAMILY HOUSE

08. CONDO/APARTMENT HOUSE (5 OR MORE
UNITS, 3 STORIES OR LESS)03. 2-FAMILY HOUSE, 2 UNITS
SIDE BY SIDE09. CONDO/APARTMENT HOUSE (5 OR MORE
UNITS, 4 STORIES OR MORE)04. 2-FAMILY HOUSE, 2 UNITS
ONE ABOVE THE OTHER10. APARTMENT IN PARTLY COMMERCIAL
STRUCTURE

05. DETACHED 3-4 FAMILY HOUSE

97. OTHER: _____
_____06. ROW HOUSE (3 OR MORE UNITS
IN AN ATTACHED ROW)ZZ3. NEIGHBORHOOD: Look at the structures on R's block and check as many as apply.

A. VACANT LAND

H. CONDO/APARTMENT HOUSE (5 OR MORE
UNITS, 3 STORIES OR LESS)

B. TRAILER/MOBILE HOME

J. CONDO/APARTMENT HOUSE (5 OR MORE
UNITS, 4 STORIES OR MORE)

C. DETACHED SINGLE FAMILY HOUSE

K. COMMERCIAL OR INDUSTRIAL STRUCTURE

D. 2-FAMILY HOUSE; SIDE BY SIDE
OR ONE ABOVE THE OTHER

L. PARK

E. DETACHED 3-4 FAMILY HOUSE

M. SCHOOL OR OTHER GOV'T. BUILDING

F. ROW HOUSE (3 OR MORE UNITS
IN AN ATTACHED ROW)

N. VACANT BUILDING

G. APARTMENT HOUSE (4 OR FEWER
UNITS)

P. OTHER: _____

ZZ4. BUILDINGS IN THE IMMEDIATE NEIGHBORHOOD (LOOK UP AND DOWN THE BLOCK) ARE:

1. ALL RESIDENTIAL

2. MOSTLY RESIDENTIAL

3. ABOUT EQUALLY RESIDENTIAL
AND NONRESIDENTIAL

4. MOSTLY NONRESIDENTIAL

0. NONE IN VIEW

ZZ5. HOUSING STRUCTURES ON BLOCK ARE:

1. 0-20 FEET APART

2. 21-100 FEET APART

3. OVER 100 FEET APART

ZZ6. CONDITION OF BUILDING EXTERIOR IS:

1. CLEAN AND
SOUND

2. SOME PAINT PEELING
OR CRACKS IN MASONRY

3. NEEDS SUBSTANTIAL
PAINTING, REFILLING,
OR REPAIR

4. DILAPIDATED

ZZ7. CONDITION OF THE EXTERIOR OF BUILDINGS ON BLOCK IN GENERAL (BOTH SIDES OF STREET) LOOKS:

1. BETTER THAN R'S

2. AS GOOD AS R'S

3. WORSE THAN R'S

0. NO OTHER BUILDINGS
IN VIEW

ZZ8. PLEASE RATE THE PHYSICAL CONDITION OF THE INTERIOR OF THE HU:

1. EXCELLENT: WALLS AND
CEILINGS HAVE NO CRACKS;
PAINT OR PANELLING IS IN
GOOD CONDITION

2. GOOD: NEEDS SOME MINOR
PAINTING OR REFINISHING

3. FAIR: NEEDS MAJOR
INTERIOR WORK--HOLES
AND/OR CRACKS NEED
PATCHING, PAINTING
NEEDED, ETC.

4. POOR: SOME WALLS OR
CEILINGS NEED REPLACEMENT

8. DON'T KNOW--WASN'T INSIDE HOUSE

ZZ9. NEIGHBORHOOD RESIDENTS SEEM TO BE:

1. ALL BLACK

2. ALMOST ALL
BLACK

3. HALF BLACK AND
HALF NON-BLACK

4. ALMOST ALL
NON-BLACK

5. ALL NON-
BLACK

8. DON'T KNOW

ZZ10. R'S UNDERSTANDING OF THE QUESTIONS WAS . . .

- 1. EXCELLENT
- 2. GOOD
- 3. FAIR
- 4. POOR

ZZ11. R'S ABILITY TO EXPRESS (HIMSELF/HERSELF) WAS . . .

- 1. EXCELLENT
- 2. GOOD
- 3. FAIR
- 4. POOR

ZZ12. WAS R SUSPICIOUS ABOUT THE STUDY BEFORE THE INTERVIEW?

- 1. NO, NOT AT ALL SUSPICIOUS
- 2. YES, SOMEWHAT SUSPICIOUS
- 5. YES, VERY SUSPICIOUS

ZZ13. WAS R SUSPICIOUS ABOUT THE STUDY AFTER THE INTERVIEW?

- 1. NO, NOT AT ALL SUSPICIOUS
- 2. YES, SOMEWHAT SUSPICIOUS
- 5. YES, VERY SUSPICIOUS

ZZ14. OVERALL, HOW GREAT WAS R'S INTEREST IN THE INTERVIEW?

- 1. VERY HIGH
- 2. ABOVE AVERAGE
- 3. AVERAGE
- 4. BELOW AVERAGE
- 5. VERY LOW

ZZ15. OTHER PERSONS PRESENT AT THE INTERVIEW: (CHECK ALL THAT APPLY.)

- A. CHILDREN UNDER 6
- B. CHILDREN 6 & OVER
- C. SPOUSE
- D. OTHER RELATIVES
- E. OTHER ADULTS
- F. NO ONE

ZZ16. DID R REFER TO DOCUMENTS TO ANSWER QUESTIONS?

- 1. FREQUENTLY
 - 2. SOMETIMES
 - 4. RARELY
 - 5. NEVER
- ↓
- GO TO ZZ18

ZZ17. WHICH DOCUMENTS DID R REFER TO? (CHECK ALL THAT APPLY)

- A. LOAN DOCUMENTS
- B. CHECKING; SAVINGS; INVESTMENTS
- C. PENSION DOCUMENTS
- D. INCOME TAX RETURN

For Office Use Only

PANEL SCF

SUPPLEMENTAL BOOKLET



The University of Michigan
Survey Research Center
Institute for Social Research
Ann Arbor, MI 48106

INTERVIEWER LABEL

1. IWER ID No.: _____

2. Your IW No.:

3. Date of IW: _____

SECTION S: EMPLOYMENT OF R'S SPOUSE

S1. We are interested in your (husband's/wife's) present job status. Is (he/she) working now, temporarily laid off, unemployed and looking for work, disabled and unable to work, retired, a student (a homemaker), or what? CHECK ALL THAT APPLY

IF S IS "WORKING NOW" AND ANY OTHER CATEGORY, ASK ALL FOLLOW-UP QUESTIONS AND GO TO NEXT PAGE, S2.

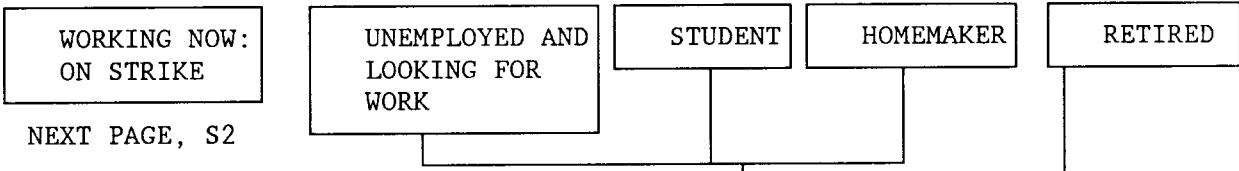

TEMPORARILY LAID OFF; ON SICK OR OTHER LEAVE

OTHER: _____

S1a. Does (he/she) expect to go back to this job?

1. YES 5. NO

S1b. When did (he/she) last work on this job?

MONTH/YEAR

NOTE: CONSIDER THIS S's "CURRENT MAIN JOB" FOR PURPOSES OF S2-S39a

NEXT PAGE, S2

S1c. Is (he/she) doing any work for pay at the present time?

1. YES -> NEXT PAGE, S2

5. NO -> TURN TO P. 14a, S44c

S1d. When did (he/she) (retire/become disabled)?

_____ YEAR

S1e. About how much was (he/she) earning when (he/she) (retired/became disabled?) (Is that per hour, per week, month, year, or what?)

\$ _____ PER _____

S1f. Is (he/she) doing any work for pay at the present time?

1. YES ->NEXT PAGE S2

5. NO ->TURN TO P. 14a, S44c

S2. Next are some questions about (his/her) current, main job. Does (he/she) work for someone else, is (he/she) self-employed, or what?

1. SOMEONE
ELSE

2. SELF-
EMPLOYED

IF R SAYS, "RUNS OWN BUSINESS"
CHECK "SELF-EMPLOYED".

TURN TO P. 4, S14



S3. What is the official title of (his/her) job? (The title that (his/her) employer uses?)

OFFICIAL JOB TITLE

S4. What sort of work does (he/she) do on (his/her) main job? (Tell me a little more about what (he/she) does.)

S5. What kind of business or industry does (he/she) work in--that is, what do they make or do at the place where (he/she) works?

S6. How many hours does (he/she) work on (his/her) main job in a normal week?

_____ # HOURS

S7. (READ SLOWLY) Counting paid vacations as weeks of work, how many weeks per year does (he/she) work on this job in a normal year?

_____ # WEEKS

S8. About how much does (he/she) earn before taxes on (his/her) main job? (Is that per hour, week, month, year, or what?)

\$ _____ PER _____

S9. About how many employees work for this company or organization, including all locations? (Is it fewer than 10, 10 to 19, 20 to 99, 100 to 499, or 500 or more?)

1. LESS THAN 10	2. 10 TO 19	3. 20 TO 99	4. 100 TO 499	5. 500 OR MORE
-----------------	-------------	-------------	---------------	----------------

S10. How many years in total has (he/she) worked for this employer?

_____ # YEARS OR SINCE _____

S11. How many years does (he/she) expect to continue working for this employer? (ACCEPT RANGE.)

_____ # YEARS OR UNTIL AGE: _____

96. NEVER STOP	98. DON'T KNOW
----------------	----------------

S12. Is (he/she) covered on this job by a union or employee-association contract?

1. YES	5. NO
--------	-------

TURN TO P. 5, S15

S13. NO QUESTION

SPOUSE IS SELF-EMPLOYED

S14. What sort of work does (he/she) do? [Tell me a little more about what (he/she) does.] (IWER: IF S WORKS FOR BUSINESS REPORTED IN SECTION M, MARK BOX.)

[]

S14a. What industry does (he/she) work in? That is, what do they do or make? (What industry does (he/she) typically work in?)

S14b. How many years has (he/she) worked for (himself/herself/this business)?

_____ # YEARS OR SINCE _____

S14c. About how many years does (he/she) expect to continue working for (himself/herself/this business)? ACCEPT RANGE

_____ # YEARS OR UNTIL AGE: _____

96. NEVER STOP

98. DON'T KNOW

S14d. How many hours does (he/she) work (for himself/for herself/in this business) in a normal week?

_____ # HOURS

S14e. (READ SLOWLY) Counting paid vacations as weeks of work, how many weeks per year does (he/she) work on this job?

_____ # WEEKS

S14f. How is (he/she) paid? Is (he/she) paid a regular salary or wages, does (he/she) receive a portion of the net earnings, or what? (CHECK ALL THAT APPLY AND ASK BOTH FOLLOW-UP QUESTIONS IF APPLICABLE.)

A. SALARY

B. WAGES

C. NET EARNINGS

D. OTHER

S14g. How much in salary or wages is (he/she) paid before taxes? \$ _____ PER _____

S14h. (In addition to regular salary,) how much does (he/she) personally earn from the business before taxes? (What did (he/she) earn in 1988) \$ _____ PER _____

S14j. Is (he/she) covered on this job by a union or employee-association contract?

1. YES

5. NO

S14k. Aside from IRA or Keogh plans, is (he/she) included in any pension plans or tax-deferred savings plans through [(his/her) work/the business]?

1. YES

-->NEXT PAGE, S17

5. NO

-->TURN TO P. 14, S40

S15. Many employers have pension or retirement plans, and some provide tax-deferred plans such as thrift, savings, 401K's, profit sharing, or stock ownership plans. Is (he/she) included in any pension or retirement plans, or in any tax-deferred savings plans on this job? (DO NOT INCLUDE SOCIAL SECURITY.)

IF R MENTIONS IRA OR KEOGH PLANS, NOTE IN MARGIN AND SAY: "We covered those earlier in the interview. Here, I just want to find out about other plans operated through (his/her) employer."

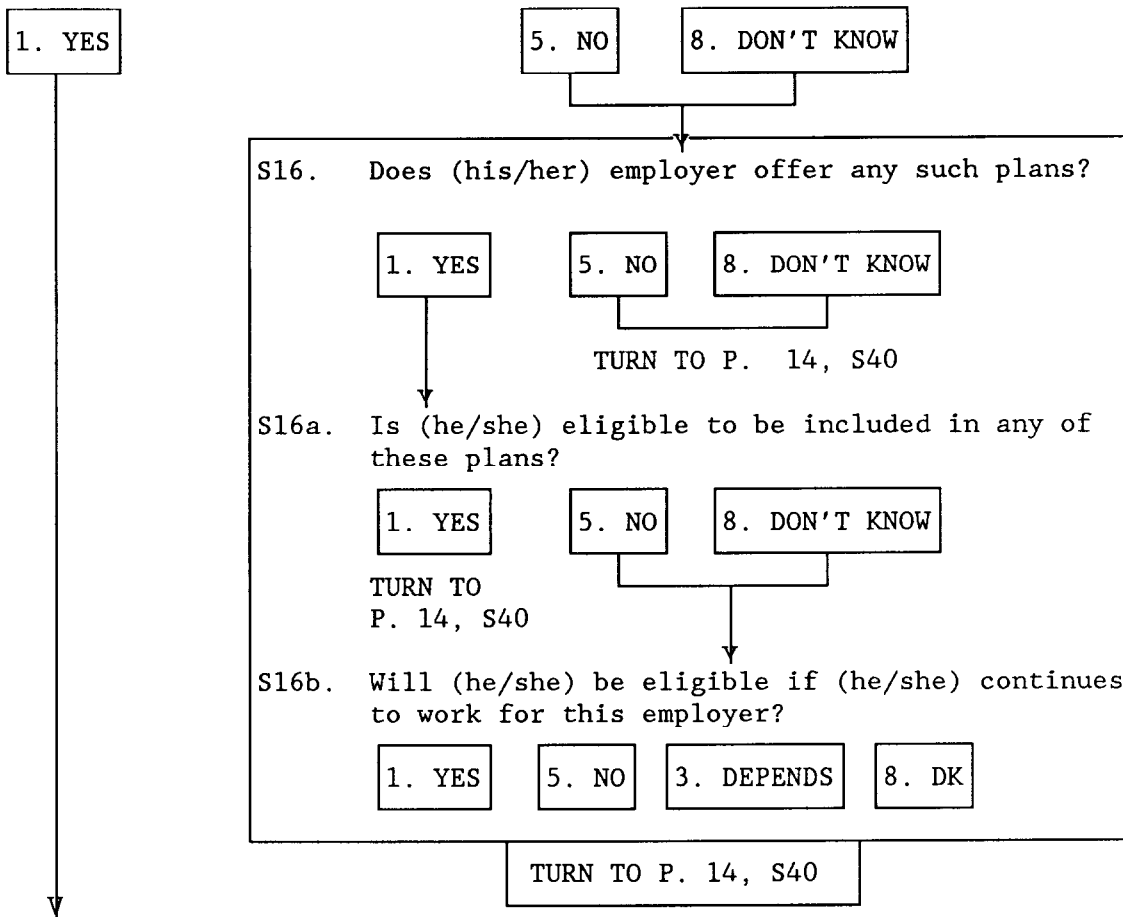

S17. In how many different plans of this sort is (he/she) included on this job?

_____ # PLANS

S17a. Is (he/she) currently receiving benefit payments from any retirement plans from this job?

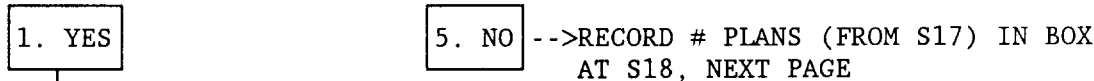

S17b. I'll ask about the benefits later. Are there any retirement or savings plans from this job where (he/she) is not yet drawing benefit payments?

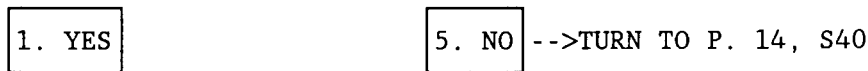

S17c. How many such plans does (he/she) have?

_____ # PLANS--NOT YET RECEIVING BENEFITS

RECORD # PLANS IN BOX AT S18, NEXT PAGE

S18.

[]

OF PLANS

PLAN 1

S19. (Is this/About the (next) most important of these plans, is it) a pension or retirement plan, or a tax-deferred savings plan of some sort? (IF R ASKS: 401-K, 403-B, ESOP, SRA, THRIFT SAVINGS, STOCK OWNERSHIP, AND PROFIT-SHARING ARE ALL TAX DEFERRED SAVINGS PLANS.)

1. PENSION OR RETIREMENT -->GO TO S20

2. TAX-DEFERRED SAVINGS -->TURN TO P. 10, S28, PLAN 1

7. OTHER

8. DON'T KNOW WHAT KIND

S20. I would like to know what general type of plan this is. In the most common pension or retirement plan, Type A, the amount of the benefit is usually based on a formula involving age, years of service and salary. In other plans, Type B, money is accumulated in an account for you until your retirement. Is (his/her)(first/next) plan like Type A or Type B?

1. TYPE A (FORMULA)
GO TO S22

2. TYPE B (ACCOUNT)
TURN TO P. 10, S28, PLAN 1

3. BOTH A & B

8. DK
GO TO S22

S21. For that part of (his/her) plan where money is accumulated in an account, how much is in the account?

\$ _____

DON'T KNOW

S22. Does (he/she) currently make contributions to this plan? (IF R ASKS: INCLUDE CONTRIBUTIONS THROUGH SALARY DEDUCTIONS, UNION DUES OR OTHER SOURCES)

1. YES

5. NO

8. DON'T KNOW

GO TO S24

S23. What percent of (his/her) pay or amount of money per month or year does (he/she) currently contribute?

_____ PERCENT OR \$ _____ PER _____

998. DON'T KNOW

S24. At what age does (he/she) expect to start receiving benefits from this plan?

AGE OR IN _____ YEARS

96. DON'T EXPECT BENEFITS

TURN TO P. 8, S25--PLAN 1

TURN TO P. 8, S26--PLAN 1

PLAN 2

PLAN 3

S19.

1. PENSION OR RETIREMENT -->GO TO S20
PLAN 2

2. TAX-DEFERRED SAVINGS -->TURN TO P. 11,
S28, PLAN 2

7. OTHER

8. DON'T KNOW WHAT KIND

1. PENSION OR RETIREMENT -->GO TO S20
PLAN 3

2. TAX-DEFERRED SAVINGS -->TURN TO P.11,
S28, PLAN 3

7. OTHER

8. DON'T KNOW WHAT KIND

S20.

1. TYPE A (FORMULA) GO TO S22

2. TYPE B (ACCOUNT) TURN TO P. 11, S28
PLAN 2

3. BOTH A & B

8. DK GO TO S22

1. TYPE A (FORMULA) GO TO S22

2. TYPE B (ACCOUNT) TURN TO P. 11, S28
PLAN 3

3. BOTH A & B

8. DK GO TO S22

S21.

\$ _____ DON'T KNOW

\$ _____ DON'T KNOW

S22.

1. YES

5. NO

8. DON'T KNOW

GO TO S24

1. YES

5. NO

8. DON'T KNOW

GO TO S24

S23.

_____ PERCENT OR \$ _____ PER _____

998. DON'T KNOW

_____ PERCENT OR \$ _____ PER _____

998. DON'T KNOW

S24.

_____ AGE OR IN _____ YRS

96. DON'T EXPECT BENEFITS

TURN TO P. 9
S25--PLAN 2

TURN TO P. 9,
S26--PLAN 2

_____ AGE OR IN _____ YRS

96. DON'T EXPECT BENEFITS

TURN TO P. 9
S25--PLAN 3

TURN TO P. 9,
S26--PLAN 3

TYPE A -- PLAN 1

S25. About how much does (he/she) expect (his/her) benefits to be? [As a proportion of (his/her) pay at retirement, or as an amount per month when (he/she) starts receiving them?]

\$ _____ PER _____
OR _____ PERCENT OF FINAL PAY

DON'T KNOW

S26. If (he/she) were to (leave this job/sell this business) now, would (he/she) start receiving a monthly or annual pension benefit now, would (he/she) receive one later, would (he/she) get a cash settlement now, would (he/she) get nothing or what? (IF R SAYS "ROLL OVER" MARK "CASH SETTLEMENT".)

1. BENEFIT NOW

2. BENEFIT LATER

3. CASH SETTLEMENT

4. NOTHING

7. OTHER: _____

8. DON'T KNOW

GO TO S27

S26a. About how much per month would (he/she) receive?

\$ _____ PER MONTH

DON'T KNOW

S27. INTERVIEWER CHECKPOINT
(SEE S18, P. 6)

- 1. ONLY 1 PLAN-->TURN TO P. 14, S40
- 2. ALL OTHERS-->GO BACK TO P. 7, S19, PLAN 2

TYPE A -- PLAN 2

TYPE A -- PLAN 3

S25.

\$ _____ PER _____
OR _____ PERCENT OF FINAL PAY

DON'T KNOW

\$ _____ PER _____
OR _____ PERCENT OF FINAL PAY

DON'T KNOW

S26.

- 1. BENEFIT NOW
 - 2. BENEFIT LATER
 - 3. CASH SETTLEMENT
 - 4. NOTHING
 - 7. OTHER: _____

 - 8. DON'T KNOW
- GO TO S27

- 1. BENEFIT NOW
 - 2. BENEFIT LATER
 - 3. CASH SETTLEMENT
 - 4. NOTHING
 - 7. OTHER: _____

 - 8. DON'T KNOW
- GO TO S27

S26a

\$ _____ PER MONTH

DON'T KNOW

\$ _____ PER MONTH

DON'T KNOW

S27

- 1. ONLY 2 PLANS->TURN TO P. 14, S40
- 2. ALL OTHERS->GO BACK TO P. 7, S19, PLAN 3

- 1. ONLY 3 PLANS->TURN TO P. 14, S40
- 2. ALL OTHERS-->TURN TO P. 13, S39

SAVINGS PLANS AND TYPE B PLANS

SAVINGS & TYPE B -- PLAN 1

S28. (Could you tell me a little more about this plan?) Is it a thrift or savings plan, a 401K, a profit-sharing plan, a stock purchase plan or what?

01. THRIFT OR SAVINGS	97. OTHER: _____
02. 401K/403B/SRA	_____
03. PROFIT SHARING	_____
04. STOCK PURCHASE; ESOP	98. DON'T KNOW

S29. For how many years altogether has (he/she) been included in this plan? (INCLUDE YEARS WITH OTHER EMPLOYERS, IF SAME PLAN)

_____ YEARS 98. DON'T KNOW

S30. [Does (his/her) employer/Does the business] make contributions to this plan?

1. YES	5. NO	8. DON'T KNOW
GO TO S31		

S30a. What percent of (his/her) pay or amount of money per month or year does [(his/her) employer/the business] contribute?

_____ PERCENT OR \$ _____ PER _____

998. DON'T KNOW

S31. Does (he/she) currently make contributions to this plan? (IF R ASKS: INCLUDE CONTRIBUTIONS THROUGH SALARY DEDUCTIONS, UNION DUES OR OTHER SOURCES.)

1. YES	5. NO	8. DON'T KNOW
GO TO S32		

S31a. What percent of (his/her) pay or amount of money per month or year does (he/she) currently contribute?

_____ PERCENT OR \$ _____ PER _____

998. DON'T KNOW

S32. Roughly how much money is in (his/her) account at present?

\$ _____ DON'T KNOW

S33. Can (he/she) borrow against that account?

1. YES	5. NO	8. DON'T KNOW
TURN TO P. 12, S35		

S34. Does (he/she) currently have a loan against that account?

1. YES	5. NO	-->TURN TO P. 12, S35
--------	-------	-----------------------

S34a. What is the amount of the loan balance?

\$ _____

S34b. Did you tell me about this loan earlier?

1. YES	5. NO
--------	-------

SAVINGS & TYPE B -- PLAN 2

SAVINGS & TYPE B -- PLAN 3

S28.	01. THRIFT OR SAVINGS	97. OTHER: _____		01. THRIFT OR SAVINGS	97. OTHER: _____
	02. 401K/403B/SRA	_____		02. 401K/403B/SRA	_____
	03. PROFIT SHARING	_____		03. PROFIT SHARING	_____
	04. STOCK PURCHASE; ESOP	98. DON'T KNOW		04. STOCK PURCHASE; ESOP	98. DON'T KNOW
S29.	_____ YEARS			_____ YEARS	
	98. DON'T KNOW			98. DON'T KNOW	
S30.	<div style="display: flex; justify-content: space-around;"> <div style="border: 1px solid black; padding: 2px;">1. YES</div> <div style="border: 1px solid black; padding: 2px;">5. NO</div> <div style="border: 1px solid black; padding: 2px;">8. DON'T KNOW</div> </div>			<div style="display: flex; justify-content: space-around;"> <div style="border: 1px solid black; padding: 2px;">1. YES</div> <div style="border: 1px solid black; padding: 2px;">5. NO</div> <div style="border: 1px solid black; padding: 2px;">8. DON'T KNOW</div> </div>	
	GO TO S31			GO TO S31	
S30a	_____ PERCENT OR \$ _____ PER _____			_____ PERCENT OR \$ _____ PER _____	
	998. DON'T KNOW			998. DON'T KNOW	
S31.	<div style="display: flex; justify-content: space-around;"> <div style="border: 1px solid black; padding: 2px;">1. YES</div> <div style="border: 1px solid black; padding: 2px;">5. NO</div> <div style="border: 1px solid black; padding: 2px;">8. DON'T KNOW</div> </div>			<div style="display: flex; justify-content: space-around;"> <div style="border: 1px solid black; padding: 2px;">1. YES</div> <div style="border: 1px solid black; padding: 2px;">5. NO</div> <div style="border: 1px solid black; padding: 2px;">8. DON'T KNOW</div> </div>	
	GO TO S32			GO TO S32	
S31a	_____ PERCENT OR \$ _____ PER _____			_____ PERCENT OR \$ _____ PER _____	
	998. DON'T KNOW			998. DON'T KNOW	
S32.	\$ _____			\$ _____	
	DON'T KNOW			DON'T KNOW	
S33.	<div style="display: flex; justify-content: space-around;"> <div style="border: 1px solid black; padding: 2px;">1. YES</div> <div style="border: 1px solid black; padding: 2px;">5. NO</div> <div style="border: 1px solid black; padding: 2px;">8. DON'T KNOW</div> </div>			<div style="display: flex; justify-content: space-around;"> <div style="border: 1px solid black; padding: 2px;">1. YES</div> <div style="border: 1px solid black; padding: 2px;">5. NO</div> <div style="border: 1px solid black; padding: 2px;">8. DON'T KNOW</div> </div>	
	TURN TO P. 13, S35			TURN TO P. 13, S35	
S34.	<div style="display: flex; justify-content: space-around;"> <div style="border: 1px solid black; padding: 2px;">1. YES</div> <div style="border: 1px solid black; padding: 2px;">5. NO</div> </div>			<div style="display: flex; justify-content: space-around;"> <div style="border: 1px solid black; padding: 2px;">1. YES</div> <div style="border: 1px solid black; padding: 2px;">5. NO</div> </div>	
	-->TURN TO P. 13, S35			-->TURN TO P.13, S35	
S34a	\$ _____			\$ _____	
S34b	<div style="display: flex; justify-content: space-around;"> <div style="border: 1px solid black; padding: 2px;">1. YES</div> <div style="border: 1px solid black; padding: 2px;">5. NO</div> </div>			<div style="display: flex; justify-content: space-around;"> <div style="border: 1px solid black; padding: 2px;">1. YES</div> <div style="border: 1px solid black; padding: 2px;">5. NO</div> </div>	

TURN TO P. 13, S35--PLAN 2

TURN TO P. 13, S35--PLAN 3

SAVINGS & TYPE B -- PLAN 1

S35. If (he/she) needed money in an emergency, could (he/she) withdraw some of the funds in that account?
(CHECK "YES" EVEN IF WITHDRAWAL INVOLVES PENALTY.)

1. YES

5. NO

8. DON'T KNOW

S36. If (he/she) were to (leave this job/sell the business) now, would (he/she) lose all, some, or none of the money in this account?

1. ALL

3. SOME

7. OTHER

5. NONE

S36a. What proportion would (he/she) lose?

_____ PERCENT

OR

S37. How is the money in this account invested? Is it mostly in stocks, mostly in interest earning assets, is it split between these, or what?

1. MOSTLY OR ALL STOCK

2. MOSTLY OR ALL INTEREST EARNING

3. SPLIT

7. OTHER: _____

8. DON'T KNOW

S38. INTERVIEWER CHECKPOINT
(SEE S18, P. 6)

1. ONLY 1 PLAN-->TURN TO P. 14, S40

2. ALL OTHERS-->GO BACK TO P. 7, S19, PLAN 2

SAVINGS & TYPE B -- PLAN 2

SAVINGS & TYPE B -- PLAN 3

S35.	<div style="display: flex; justify-content: space-around;"> <div style="border: 1px solid black; padding: 2px;">1. YES</div> <div style="border: 1px solid black; padding: 2px;">5. NO</div> <div style="border: 1px solid black; padding: 2px;">8. DON'T KNOW</div> </div>	<div style="display: flex; justify-content: space-around;"> <div style="border: 1px solid black; padding: 2px;">1. YES</div> <div style="border: 1px solid black; padding: 2px;">5. NO</div> <div style="border: 1px solid black; padding: 2px;">8. DON'T KNOW</div> </div>
S36.	<div style="display: flex; justify-content: space-around; margin-bottom: 10px;"> <div style="border: 1px solid black; padding: 2px;">1. ALL</div> <div style="border: 1px solid black; padding: 2px;">3. SOME</div> <div style="border: 1px solid black; padding: 2px;">7. OTHER</div> </div> <div style="border: 1px solid black; padding: 2px; margin-bottom: 10px;">5. NONE</div> <p style="text-align: center;">S36a. What proportion would (he/she) lose?</p> <p style="text-align: center;">_____ PERCENT</p> <p style="text-align: center;">OR</p> <p style="text-align: center;">_____</p>	<div style="display: flex; justify-content: space-around; margin-bottom: 10px;"> <div style="border: 1px solid black; padding: 2px;">1. ALL</div> <div style="border: 1px solid black; padding: 2px;">3. SOME</div> <div style="border: 1px solid black; padding: 2px;">7. OTHER</div> </div> <div style="border: 1px solid black; padding: 2px; margin-bottom: 10px;">5. NONE</div> <p style="text-align: center;">S36a. What proportion would (he/she) lose?</p> <p style="text-align: center;">_____ PERCENT</p> <p style="text-align: center;">OR</p> <p style="text-align: center;">_____</p>
S37.	<div style="display: flex; justify-content: space-between; margin-bottom: 10px;"> <div style="border: 1px solid black; padding: 2px; width: 30%;">1. MOSTLY OR ALL STOCK</div> <div style="border: 1px solid black; padding: 2px; width: 30%;">2. MOSTLY OR ALL INTEREST EARNING</div> <div style="border: 1px solid black; padding: 2px; width: 30%;">3. SPLIT</div> </div> <div style="display: flex; justify-content: space-between; margin-bottom: 10px;"> <div style="border: 1px solid black; padding: 2px; width: 60%;">7. OTHER: _____</div> <div style="border: 1px solid black; padding: 2px; width: 35%;">8. DON'T KNOW</div> </div>	<div style="display: flex; justify-content: space-between; margin-bottom: 10px;"> <div style="border: 1px solid black; padding: 2px; width: 30%;">1. MOSTLY OR ALL STOCK</div> <div style="border: 1px solid black; padding: 2px; width: 30%;">2. MOSTLY OR ALL INTEREST EARNING</div> <div style="border: 1px solid black; padding: 2px; width: 30%;">3. SPLIT</div> </div> <div style="display: flex; justify-content: space-between; margin-bottom: 10px;"> <div style="border: 1px solid black; padding: 2px; width: 60%;">7. OTHER: _____</div> <div style="border: 1px solid black; padding: 2px; width: 35%;">8. DON'T KNOW</div> </div>
S38.	<div style="margin-bottom: 10px;"><input type="checkbox"/> 1. ONLY 2 PLANS->NEXT PAGE, S40</div> <div><input type="checkbox"/> 2. ALL OTHERS->GO BACK TO P. 7, S19, PLAN 3</div>	<div style="margin-bottom: 10px;"><input type="checkbox"/> 1. ONLY 3 PLANS->NEXT PAGE, S40</div> <div><input type="checkbox"/> 2. ALL OTHERS</div>

S39. (IF 4 OR MORE) Altogether how much does (he/she) have in (his/her) account balance(s) for any other pension plans or savings plan(s) from this job?

\$ _____

NEXT PAGE, S40

DON'T KNOW

NOTHING

S39a. Altogether, what other benefit payments does (he/she) expect to receive from (this/these) other pension plan(s) from this job?

DON'T KNOW

NONE

S40. Is (he/she) doing any other work for pay now, such as a second job, the military reserves, or (another) business of (his/her) own?

1. YES 5. NO -->GO TO S44

S40a. Is this a second job, the military reserves, (his/her) own business, or what? (CHECK ALL THAT APPLY.)

A. SECOND JOB B. MILITARY C. BUSINESS D. OTHER: _____

GO TO S41

GO TO S41

S40b. IWER: IF BUSINESS IS ONE OF THE BUSINESSES REPORTED IN SECTION M, MARK BOX. []

S41. How many hours does (he/she) work on these other jobs in a normal week?

_____ #HOURS

S42. Counting paid vacations as weeks of work, how many weeks per year does (he/she) work on these other jobs in a normal year?

_____ # WEEKS

S43. About how much does (he/she) earn before taxes from these other jobs? (Is that per hour, week, month, year, or what?)

\$ _____ PER _____

S44. Thinking about all (his/her) current work for pay, does (he/she) consider (himself/herself) to be working full-time or part-time?

(IWER: IF S IS LAID OFF OR A SEASONAL WORKER, ASK ABOUT "JOBS WHEN S IS WORKING".)

1. FULL-TIME 2. PART-TIME -->NEXT PAGE, S44b

NEXT PAGE, S44a

S44a. INTERVIEWER CHECKPOINT

SEE HHL UPDATE, ITEM #2

1. R MARRIED TO SAME PERSON AS IN (YEAR OF LAST INTERVIEW)--->TURN TO P. 15, S45
2. R MARRIED TO DIFFERENT PERSON THAN IN (YEAR OF LAST INTERVIEW)--->TURN TO P. 21, SS45

S44b. INTERVIEWER CHECKPOINT

SEE HHL UPDATE, ITEM #2

1. R MARRIED TO SAME PERSON AS IN (YEAR OF LAST INTERVIEW)--->TURN TO P. 17, S46
2. R MARRIED TO DIFFERENT PERSON THAN IN (YEAR OF LAST INTERVIEW)--->TURN TO P. 23, SS46

S44c. INTERVIEWER CHECKPOINT

SEE HHL UPDATE, ITEM #2

1. R MARRIED TO SAME PERSON AS IN (YEAR OF LAST INTERVIEW)--->TURN TO P. 19, S47
2. R MARRIED TO DIFFERENT PERSON THAN IN (YEAR OF LAST INTERVIEW)--->TURN TO P. 25, SS47

14b

THIS IS A BLANK PAGE

WORK HISTORY FOR SPOUSE CURRENTLY WORKING FULL-TIME

S45. Now I have a few questions about (his/her) past jobs. Was (he/she) working for pay in January 1983?

1. YES 5. NO -->GO TO S45e



S45a. Was that January 1983 job with (his/her) present employer, another employer, was (he/she) self-employed, or what? (IF SELF-EMPLOYED BOTH IN 1983 AND NOW, CHECK "PRESENT EMPLOYER")

- | | | | | |
|---------------------|-----------------------|-------------------------------|-------------------------------|-----------------|
| 1. PRESENT EMPLOYER | 2. DIFFERENT EMPLOYER | 3. SELF-EMPL IN 1983, NOT NOW | 4. SELF-EMPL NOW, NOT IN 1983 | 7. OTHER: _____ |
|---------------------|-----------------------|-------------------------------|-------------------------------|-----------------|

GO TO S45e

GO TO S45e



S45b. What was the reason (he/she) left (that job/self-employment)? Did (he/she) retire, become disabled, quit, was (he/she) laid off, did the business close, or what?

- | | | | | | |
|------------|-------------|---------|-------------|--------------------|----------|
| 1. RETIRED | 2. DISABLED | 3. QUIT | 4. LAID OFF | 5. BUSINESS CLOSED | 6. FIRED |
|------------|-------------|---------|-------------|--------------------|----------|

7. OTHER: _____

S45c. Was (he/she) included in a pension or retirement plan on that job?

1. YES 5. NO -->GO TO S45e



S45d. Did (he/she) get a cash settlement from that pension plan, does (he/she) expect to get retirement benefits from that plan in future, is (he/she) getting retirement benefits from that plan now, or what? (CHECK ALL THAT APPLY)

- | | | | | |
|--------------------|---------------------------|-------------------------|----------------|----------|
| A. CASH SETTLEMENT | B. EXPECT FUTURE BENEFITS | C. GETTING BENEFITS NOW | D. NO BENEFITS | E. OTHER |
|--------------------|---------------------------|-------------------------|----------------|----------|

READ: I will ask about these benefits later. Now I want to ask about the last three years.



S45e. During the past 36 months, that is the last three years, how many months has (he/she) worked full-time?

_____ # OF MONTHS

S45f. How many different employers has (he/she) had on full-time jobs over the past 36 months?

_____ # OF EMPLOYERS

S45g. Have there been any months over this period when (he/she) only worked part-time?

1. YES 5. NO -----> GO TO S45m



S45h. How many of the past 36 months has (he/she) only worked part-time?

_____ # OF MONTHS

S45i - S45k: NO QUESTIONS

S45m. Thinking now of the future, when does (he/she) expect to stop working full-time?

IN _____ YEARS OR AT AGE _____

96. NEVER STOP -->GO TO S45q

S45n. Does (he/she) expect to work part-time after that?

1. YES 5. NO 8. DON'T KNOW/DEPENDS

GO TO S45q



S45p. When does (he/she) expect to stop working altogether?

IN _____ YEARS OR AT AGE _____

98. DEPENDS/DK

96. NEVER STOP

S45q. RETURN TO MAIN QUESTIONNAIRE, P97, R50

WORK HISTORY FOR SPOUSE WORKING PART-TIME NOW

S46. Now I have a few questions about (his/her) past jobs. Was (he/she) working for pay in January 1983?

1. YES

5. NO -->GO TO S46e



S46a. Was that January 1983 job with (his/her) present employer, another employer, was (he/she) self-employed, or what? (IF SELF-EMPLOYED BOTH IN 1983 AND NOW, CHECK "PRESENT EMPLOYER")

1. PRESENT
EMPLOYER

2. DIFFERENT
EMPLOYER

3. SELF-EMPL
IN 1983,
NOT NOW

4. SELF-EMPL
NOW, NOT
IN 1983

7. OTHER: _____

GO TO S46e

GO TO S46e



S46b. What was the reason (he/she) left (that job/self-employment)? Did (he/she) retire, become disabled, quit, was (he/she) laid off, did the business close, or what?

1. RETIRED

2. DISABLED

3. QUIT

4. LAID OFF

5. BUSINESS CLOSED

6. FIRED

7. OTHER: _____

S46c. Was (he/she) included in a pension or retirement plan on that job?

1. YES

5. NO -->GO TO S46e



S46d. Did (he/she) get a cash settlement from that pension plan, does (he/she) expect to get retirement benefits from that plan in future, is (he/she) getting retirement benefits from that plan now, or what? (CHECK ALL THAT APPLY)

A. CASH
SETTLEMENT

B. EXPECT
FUTURE
BENEFITS

C. GETTING
BENEFITS
NOW

D. NO
BENEFITS

E. OTHER

READ: I will ask about these benefits later. Now I want to ask about the last three years.



S46e. During the past 36 months, that is the last three years, how many months has (he/she) worked part-time?

_____ # OF MONTHS

S46f. Have there been any months over this period when (he/she) worked full-time?

1. YES 5. NO -----> GO TO S46p



S46g. How many of the past 36 months has (he/she) worked full-time?

_____ # OF MONTHS

S46h. How many different employers has (he/she) had on full-time jobs over this time?

_____ # OF EMPLOYERS

S46i. When did (he/she) last work full-time for pay?

MONTH / YEAR

S46k - S45n: NO QUESTIONS

S46p. Thinking now of the future, does (he/she) expect to do any full-time work for pay?

1. YES 5. NO 8. DON'T KNOW/DEPENDS

GO TO S46s



S46q. When does (he/she) expect to start working full-time?

IN _____ YEARS OR AT AGE _____ 98. DON'T KNOW/DEPENDS

S46r. And when does (he/she) expect to stop working full-time?

IN _____ YEARS OR AT AGE _____ 98. DON'T KNOW/DEPENDS 96. NEVER STOP

GO TO S46t



S46s. When does (he/she) expect to stop working for pay altogether?

IN _____ YEARS OR AT AGE _____ 98. DON'T KNOW/DEPENDS 96. NEVER STOP

S46t. RETURN TO MAIN QUESTIONNAIRE, P97, R50

WORK HISTORY FOR SPOUSE CURRENTLY RETIRED/DISABLED, HOMEMAKER, STUDENT, OR OTHER

S47. Now I have a few questions about (his/her) past jobs. Was (he/she) working for pay in January 1983?

1. YES 5. NO -->GO TO S47d



S47a. What was the reason (he/she) left that job? Did (he/she) retire, become disabled, quit, was (he/she) laid off, did the business close, or what?

1. RETIRED 2. DISABLED 3. QUIT 4. LAID OFF 5. BUSINESS CLOSED 6. FIRED

7. OTHER: _____

S47b. Was (he/she) covered by a pension or retirement plan on that job?

1. YES 5. NO -->GO TO S47d



S47c. Did (he/she) get a cash settlement from that pension plan, does (he/she) expect to get retirement benefits from that plan in future, is (he/she) getting retirement benefits from that plan now, or what? (CHECK ALL THAT APPLY)

- | | | | | |
|--------------------|---------------------------|-------------------------|----------------|----------|
| A. CASH SETTLEMENT | B. EXPECT FUTURE BENEFITS | C. GETTING BENEFITS NOW | D. NO BENEFITS | E. OTHER |
|--------------------|---------------------------|-------------------------|----------------|----------|

READ: I will ask about these benefits later.
Now I want to ask you about any work you have done over the last three years.



S47d. During the last three years, or 36 months, has (he/she) done any work for pay?

1. YES 5. NO --> NEXT PAGE, S47p



S47e. How many months over this period has (he/she) worked full-time?

_____ # MONTHS NONE ----->GO TO S47g

S47f. How many different employers has (he/she) had on full-time jobs over this time?

_____ # OF EMPLOYERS

S47g. How many months over this period has (he/she) only worked part-time?

_____ # MONTHS NONE

S47h - S47n: NO QUESTIONS

S47p. Does (he/she) expect to work for pay in the future?

1. YES

5. NO → GO TO S47v



S47q. When does (he/she) expect to start working?

IN _____ YEARS OR AT AGE _____

98. DON'T KNOW/DEPENDS

S47r. Will any of that be full-time work?

1. YES

5. NO

8. DON'T KNOW/DEPENDS



GO TO S47u

S47s. When does (he/she) expect to start working full-time?

IN _____ YEARS OR AT AGE _____

98. DON'T KNOW/
DEPENDS

S47t. And when does (he/she) expect to stop working full-time?

IN _____ YEARS OR AT AGE _____

96. NEVER STOP



GO TO S47v

S47u. When does (he/she) expect to stop working for pay altogether?

IN _____ YEARS OR AT AGE _____

98. DON'T KNOW/
DEPENDS

96. NEVER
STOP

S47v. RETURN TO MAIN QUESTIONNAIRE, P97, R50

WORK HISTORY FOR SPOUSE CURRENTLY WORKING FULL-TIME (DIFFERENT SPOUSE)

SS45. (READ SLOWLY:) Now I have a few questions about (his/her) past jobs. Including any periods of self-employment, the military, and (his/her) current job, since (he/she) was 18, how many years has (he/she) worked full-time for all or most of the year? (Roughly how many years?)

_____ # YEARS 96. NONE → NEXT PAGE, SS45j

SS45a. Including any self-employment and (his/her) current job, for how many different employers has (he/she) worked in full-time jobs lasting one year or more?

_____ # EMPLOYERS

SS45b. Now, not counting (his/her) current job, has (he/she) ever had a full-time job that lasted for three years or more?

1. YES

5. NO --->NEXT PAGE, SS45j

SS45c. I want to know about the longest such job (he/she) had. Did (he/she) work for someone else, was (he/she) self-employed, or what?

1. SOMEONE ELSE

2. SELF-EMPLOYED

7. OTHER: _____

SS45d. What sort of work was (he/she) doing when (he/she) left that job? (Tell me a little more about what [he/she] did.)

SS45e. What kind of business or industry did (he/she) work in -- that is, what did they make or do at the place where (he/she) worked?

SS45f. When did (he/she) start working at that job?

19 _____ OR _____ YEARS AGO

SS45g. When did (he/she) stop working at that job?

19 _____ OR _____ YEARS AGO

WORK HISTORY FOR SPOUSE CURRENTLY WORKING FULL-TIME (DIFFERENT SPOUSE)

SS45h. About how much was (he/she) earning before taxes when (he/she) stopped? (Is that per hour, week, month, year, or what?)

\$ _____ PER _____

SS45j. Since (he/she) was 18, have there been years when (he/she) only worked part-time for all or most of the year?

1. YES 5. NO → GO TO SS45m



SS45k. About how many years in total did (he/she) work part-time for all or most of the year?

_____ # YEARS

SS45m. Thinking now of the future, when does (he/she) expect to stop working full-time?

IN _____ YEARS OR AT AGE _____

96. NEVER STOP --> GO TO SS45q

SS45n. Does (he/she) expect to work part-time after that?

1. YES 5. NO 8. DON'T KNOW/DEPENDS



GO TO SS45q



SS45p. When does (he/she) expect to stop working altogether?

IN _____ YEARS OR AT AGE _____

98. DEPENDS/DK 96. NEVER STOP

SS45q. RETURN TO MAIN QUESTIONNAIRE, P. 97, R50

WORK HISTORY FOR SPOUSE WORKING PART-TIME NOW (DIFFERENT SPOUSE)

SS46. Now I have a few questions about (his/her) past jobs. Including any self-employment and (his/her) current job, since (he/she) was 18, about how many years in total has (he/she) worked part-time for all or most of the year? (Roughly how many years?)

_____ # YEARS OR 96. LESS THAN 1 YEAR

SS46a. Since (he/she) was 18, has (he/she) ever worked full-time for pay--including any self-employment and the military?

1. YES

5. NO ->NEXT PAGE, SS46p

SS46b. How many years has (he/she) worked full-time for all or most of the year? (Roughly how many years?)

_____ # YEARS

SS46c. INTERVIEWER CHECKPOINT -- SEE SS46b

1. SPOUSE HAS WORKED AT LEAST 5 YEARS FULL-TIME OR DK	2. ALL OTHERS
---	---------------

SS46d. When did (he/she) last work full time for pay?

19 _____ OR _____ # YEARS AGO

SS46e. About how much did (he/she) earn before taxes that year? (Is that per hour, week, month, year, or what?)

\$ _____ PER _____

NEXT PAGE, SS46p

SS46f. Including any self-employment and (his/her) current job, for how many different employers has (he/she) worked in full-time jobs lasting one year or more?

_____ # EMPLOYERS

SS46g. I want to know about the longest full-time job (he/she) had. Did (he/she) work for someone else, was (he/she) self-employed, or what?

1. SOMEONE ELSE

2. SELF-EMPLOYED

7. OTHER: _____

SS46h. What sort of work was (he/she) doing when (he/she) left that job? (Tell me a little more about what (he/she) did.)

WORK HISTORY FOR SPOUSE WORKING PART-TIME NOW (DIFFERENT SPOUSE) (CONT)

SS46i. What kind of business or industry did (he/she) work in -- that is, what did they make or do at the place where (he/she) worked?

SS46j. When did (he/she) start working at that job?

19 _____ OR _____ YEARS AGO

SS46k. When did (he/she) stop working at that job?

19 _____ OR _____ YEARS AGO

SS46m. About how much was (he/she) earning before taxes when (he/she) stopped? (Is that per hour, week, month, year, or what?)

\$ _____ PER _____

SS46n. When did (he/she) last work full-time for pay?

19 ____ OR _____ # YEARS AGO

SS46p. Thinking now of the future, does (he/she) expect to do any full-time work?

1. YES

5. NO

8. DON'T KNOW/DEPENDS

GO TO SS46s



SS46q. When does (he/she) expect to start working full-time?

IN _____ YEARS OR AT AGE _____

98. DON'T KNOW/DEPENDS

SS46r. And when does (he/she) expect to stop working full-time?

IN _____ YEARS OR AT AGE _____

98. DON'T KNOW/DEPENDS

96. NEVER STOP

GO TO SS46t



SS46s. When does (he/she) expect to stop working for pay altogether?

IN _____ YEARS OR AT AGE _____

98. DON'T KNOW/DEPENDS

96. NEVER STOP

SS46t. RETURN TO MAIN QUESTIONNAIRE, P. 97, R50

SS47. Since (he/she) was 18 has (he/she) ever worked full-time for pay?

1. YES

5. NO -> NEXT PAGE, SS47m



SS47a. How many years has (he/she) worked full-time for all or most of the year? Include any periods of self-employment, and the military. (Roughly how many years?)

_____ # YEARS

SS47b. INTERVIEWER CHECKPOINT -- SEE SS47a

1. SPOUSE HAS WORKED AT LEAST 5 YEARS FULL-TIME

2. ALL OTHERS



SS47c. When did (he/she) last work full-time?

19 _____ OR _____ YEARS AGO

SS47d. About how much did (he/she) earn before taxes that year? (Is that per hour, week, month, year, or what?)

\$ _____ PER _____

NEXT PAGE, SS47m



SS47e. Including any self-employment and (his/her) current job, for how many different employers has (he/she) worked in full-time jobs lasting one year or more?

_____ # EMPLOYERS

SS47f. I want to know about the longest full-time job (he/she) had. Did (he/she) work for someone else, was (he/she) self-employed, or what?

1. SOMEONE ELSE

2. SELF-EMPLOYED

7. OTHER: _____

SS47g. What sort of work was (he/she) doing when (he/she) left that job? [Tell me a little more about what (he/she) did.]

SS47h. What kind of business or industry did (he/she) work in -- that is, what did they make or do at the place where (he/she) worked?

SS47i. When did (he/she) start working at that job?

19 _____ OR _____ YEARS AGO

SS47j. When did (he/she) stop working at that job?

19 _____ OR _____ YEARS AGO

WORK HISTORY FOR SPOUSE RETIRED/DISABLED, HOMEMAKER, STUDENT, OR OTHER (CONT)

SS47k. About how much was (he/she) earning before taxes when (he/she) stopped?
(Is that per hour, week, month, year, or what?)

\$ _____ PER _____

SS47m. Since (he/she) was 18, were there any years when (he/she) (only) worked part-time for all or most of the year?

1. YES 5. NO → GO TO SS47p

SS47n. For about how many years did (he/she) work part-time (for all or most of the year)?

_____ YEARS

SS47p. Does (he/she) expect to work for pay in the future?

1. YES 5. NO → GO TO SS47v

SS47q. When does (he/she) expect to start working?

IN _____ YEARS OR AT AGE _____ 98. DON'T KNOW/DEPENDS

SS47r. Will any of that be full-time work?

1. YES 5. NO 8. DON'T KNOW/DEPENDS

GO TO SS47u

SS47s. When does (he/she) expect to start working full-time?

IN _____ YEARS OR AT AGE _____ 98. DON'T KNOW/DEPENDS

SS47t. And when does (he/she) expect to stop working full-time?

IN _____ YEARS OR AT AGE _____ 96. NEVER STOP

GO TO SS47v

SS47u. When does (he/she) expect to stop working for pay altogether?

IN _____ YEARS OR AT AGE _____ 98. DON'T KNOW/DEPENDS 96. NEVER STOP

SS47v. RETURN TO MAIN QUESTIONNAIRE, P. 97, R50