

Elasticity of Substitution and the Persistence of the Deviation of the Real Exchange Rates

A.K.M. Mahbub Morshed

Department of Economics, Mail Code 4515, Southern Illinois University, Carbondale, IL 62901

Stephen J. Turnovsky*

Department of Economics, Box 353330, University of Washington, Seattle, WA 98195

November 2004

Abstract

Empirical evidence suggests (i) that the real exchange rates of developing economies show less persistence than do those of more advanced economies and (ii) that the elasticity of substitution between capital and labor tends to increase from below unity for less developed economies to above one for more advanced economies. This paper shows how the introduction of sectoral adjustment costs in a two-sector model of a small open economy, together with CES production functions, provides a very natural explanation of this empirical regularity. Other aspects of the relationship between the technologies and the speed of convergence of the real exchange rate are also discussed.

JEL Classification Code: F41, O11, O41

Keywords: Real Exchange Rate, Elasticity of Substitution, Adjustment Costs.

• Corresponding author. Tel.: +1-206-685-8028; fax: +1-206-685-7477. Email-address: sturn@u.washington.edu

We wish to thank Chris Papageorgiou for some helpful comments on this paper.

1. Introduction

The recent empirical literature on the dynamic behavior of the real exchange rate has identified a number of puzzling empirical regularities (Obstfeld and Rogoff, 2001). Among the most prominent is the persistence of the deviation of the real exchange rate from its long run equilibrium value. This persistence implies that although Purchasing Power Parity (PPP) holds in the long run, any short-run deviation in the real exchange rate from its long-run equilibrium level takes a relatively long time to eliminate. Although researchers have applied different techniques and used different data sets, the consensus is that the half-life of the deviation of the real exchange rate from its long-run equilibrium is about 3-5 years (Froot and Rogoff, 1995). But as Cheung and Lai (2000) observe, there are substantial cross-country differences in the degree of persistence of the real exchange rate. Most notably, they find that estimates of the half-life of real exchange rate deviations for developing countries are significantly shorter than those for developed countries, implying that in the former the real exchange rate reverts more rapidly to its long-run equilibrium.

Two general approaches to explaining real exchange rate persistence can be identified. One is to assume that goods prices are sticky; see Obstfeld and Rogoff, (1995), Betts and Devereux (2000), Bergin and Feenstra (2001), and Chari, Kehoe, and McGrattan (2002). An alternative strategy has been to modify the two-sector production model, relaxing the conventional assumption that capital can be instantaneously and costlessly shipped across sectors, and assume instead, that the intersectoral movement of capital involves adjustment costs, reflecting the costs of retrofitting. This idea, which can be traced back to Mussa (1978) and later to Gavin (1990, 1992), has been recently applied by Steigum and Thørgesen (2003) and Morshed and Turnovsky (2004), to exchange rate dynamics.

As Morshed and Turnovsky document at length, the empirical evidence supporting the introduction of *intersectoral* adjustment costs is quite compelling. In fact, it is arguably more so than is the evidence supporting the more familiar adjustment costs associated with *aggregate* capital accumulation.¹ Since one of their concerns was to show how this more general production structure

¹ Morshed and Turnovsky (2004) discuss a diverse range of evidence supporting this position: these include adjustments in the United States following the introduction of the railroads, Fogel (1964), transitional costs in East and West Europe

encompasses both the standard Heckscher-Ohlin and specific-factors production technologies as polar cases, they based the numerical part of their analysis on simple Cobb-Douglas technologies which sufficed for this purpose. Depending upon the assumed sectoral adjustment costs and sector capital intensities, they were able to generate real exchange rate persistence of a much more plausible magnitude than that associated with the conventional Heckscher-Ohlin technology.²

But a recent cross-country study by Duffy and Papageorgiou (2000) suggests that the Cobb-Douglas production function is an inadequate representation of technology across countries. Their evidence suggests that the elasticity of substitution exceeds that of the Cobb-Douglas function (one) for rich countries, but is less than unity for developing countries. Indeed, the degree of factor substitutability has long been recognized as being a critical determinant of the speed of convergence; see Sato (1963), Atkinson (1969), Ramanathan (1975), and Turnovsky (2002). One of the findings of this literature is that a smaller elasticity of substitution will lead to a faster rate of convergence of capital and output.

Interest in the elasticity of substitution as a key parameter sensitive to the level of a country's development extends to other areas as well. For example, in his recent discussion of the empirical literature pertaining to cross-country income differences, Caselli (2003) stresses the role of the elasticity of substitution in determining the extent to which differences in factor endowments can explain the distribution of income. Since information on the elasticity of substitution across countries is quite wide-ranging, he concludes that one of the most important outstanding issues in development accounting may well be to determine the magnitude of this elasticity more precisely.

The consequences of the elasticity of factor substitution for real exchange rate dynamics have not been addressed adequately and are the focus of this paper. Our main general conclusion is that economies having less flexible technologies – in the sense of having a smaller elasticity of substitution – are also likely to have a faster speed of convergence, implying less persistence in the real exchange rate. If one combines this together with the evidence suggesting that poorer countries

after the end of the cold war, Kiss (1997), Kaldor and Schmeder (1997), and adjustment costs in the United States after the Second World War.

² For the pure Heckscher-Ohlin technology, without any sectoral adjustment costs, the real exchange rate responds instantaneously if the traded sector is relatively capital intensive. However, if the non-traded sector is relatively capital intensive, the speed of adjustment becomes finite, although still much faster than the empirical evidence suggests.

have smaller elasticities of substitution, one is led to the conclusion that the real exchange rate of developing countries will converge more rapidly than for rich, consistent with the empirical evidence of Cheung and Lai (2000). Less flexible production conditions, coupled with costly sectoral capital adjustment costs, thus provide a natural explanation for the more rapid convergence of the real exchange rate in developing economies.

The framework we employ is a dynamic version of the so-called dependent economy model. This is a general equilibrium model of a small open economy having both a traded and a nontraded sector.³ Assuming that the law of one price holds for the traded goods, the real exchange rate can be conveniently defined by the price ratio of nontraded to traded goods, P_N/P_T , where P_N and P_T represent the price of nontraded goods and the price of traded goods respectively. Since the price of the latter is determined internationally, the dependent economy cannot influence it. Consequently, the real exchange rate depends mainly on the formation of the price of nontraded goods, which in turn depends upon demand and supply conditions of the nontraded good in the dependent economy. How the nontraded output is produced is an essential determinant of the real exchange rate. At the same time, factor accumulation and factor substitutability in both sectors are also important elements in explaining real exchange rate dynamics. Indeed, an appealing feature of this approach is that it allows us to examine the behavior of the real exchange rate in a general equilibrium framework.

As in our earlier paper, much of our analysis is conducted numerically. Since our objective is to investigate the role of factor substitution on exchange rate dynamics, we assume that both the traded and nontraded sectors employ Constant Elasticity of Substitution (CES) production functions, which are particularly convenient. We consider how changes in the elasticities of substitution in the two sectors, as they increase through low, medium, and high values, influence the dynamics of the real exchange rate. Following Morshed and Turnovsky (2004), we will incorporate inter-sectoral adjustment costs associated with capital movements across sectors. In addition to our main finding that an economy with production functions exhibiting a higher elasticity of substitution of factors yields a more persistent deviation of the real exchange rate, we discuss a number of other aspects of

³Earliest applications of this model, associated with the Australian school [e.g. Salter 1959, Swan, 1960] were purely static, focusing on the demand-side determinants of the real exchange rate. Balassa (1964) and Samuelson (1964) employed a similar framework but focused more on the supply-side effects (productivity differentials) to explain the behavior of the real exchange rate.

the relationship. For example, we find a sharp contrast between the short-run and long-run speeds of convergence, as well as a striking sensitivity to the sources of the underlying shocks driving the dynamics.

The remainder of the paper is structured as follows. Section 2 sets out the basic analytical framework and derives the macroeconomic equilibrium, while Section 3 discusses the calibration of the economy. Section 4 and 5 discuss the dynamics of the real exchange and its speeds of convergence. In considering these issues we use the results of our numerical simulations to assess the sensitivity of the dynamics of the exchange rate to the flexibility in production. Finally, Section 6 concludes with a brief overview of our findings.

2. The Analytical Framework

The model we employ has been spelled out in Morshed and Turnovsky (2004), where we apply it to the case of a Cobb-Douglas technology. Since the set-up there is described for any arbitrary neoclassical technology, our description can be brief; the reader is referred to our earlier paper for further details.

We consider a small open economy inhabited by a single representative agent who is endowed with a fixed supply of labor (normalized to be one unit), which he sells at the competitive wage. The agent produces a traded good T (taken to be the numeraire) and a nontraded good N using a quantity of capital, K , and labor, L , by means of neoclassical production functions. The agent allocates his labor between these two production processes and consumes both the traded and nontraded good. The former is used only for consumption (either private or public), while the latter may be either consumed or accumulated as a capital good, to which it may be converted without incurring any adjustment costs. This assumption is made because, in order to focus on inter-sectoral adjustment costs, we wish to keep other adjustment processes as simple as possible.

The agent also accumulates net foreign bonds, B , that pay a given world interest rate r . Equation (1a) describes the agent's instantaneous budget constraint,

$$\dot{B} = F(K_T, L_T) - C_T + \sigma[H(K_N, L_N) - C_N - I] - T_L + rB \quad (1a)$$

where C_T and C_N are the agent's consumption of traded goods and nontraded goods, respectively; σ is the relative price of nontraded goods to traded goods (which assuming that PPP holds for traded goods, σ is also the real exchange rate); I denotes new investment, and T_L denotes lump-sum taxes.

We further assume that the capital stock does not depreciate and that it cannot move freely across sectors. Only nontraded new output can be converted into capital, and once it is set aside as capital in the nontraded sector, it requires extra resources to transform it into a form that is suitable for use in the traded sector. Accordingly, capital accumulation is described by:

$$\dot{K}_T = X \quad (1b)$$

$$\dot{K}_N = I - X \left(1 + \frac{h}{2} \frac{X}{K_N} \right) \quad (1c)$$

where X is the amount of capital transferred from the nontraded to the traded sector, and

$$I = H(K_N, L_N) - C_N - G_N \quad (1d)$$

identifies the amount of nontraded output available for investment as being the amount of nontraded output remaining after both private consumption, C_N , and government purchases, G_N , have been met. In order to provide X units of capital to the traded sector, the amount of capital in the nontraded sector must be reduced by more than X .⁴ This excess amount, $hX^2/2K_N > 0$ represents the sectoral adjustment costs.⁵ This specification is analogous to the standard specifications of aggregate adjustment costs based on Hayashi (1982), and preserves the conventional properties.

Summing (1b) and (1c), the total rate of capital accumulation in the economy, \dot{K} , is

$$\dot{K} \equiv \dot{K}_T + \dot{K}_N = I - \frac{hX^2}{2K_N} \quad (1e)$$

where the last term in (1e) denotes the loss in capital due to sectoral movements. In the absence of

⁴ As usual, the formulation permits negative aggregate investment. The usual interpretation of this is that the agent is permitted to consume his capital stock or sell it in the market for new output.

⁵ Morshed and Turnovsky (2004) show how varying h from 0 through ∞ enables them to encompass the standard Heckscher-Ohlin technology at one extreme and the sector-specific capital model at the other. Grossman (1983) has a similar index of capital mobility measured by the percentage loss in efficiency that is incurred in transforming the marginal unit of capital.

sectoral adjustment costs, (1e) reduces to the standard aggregate capital accumulation relationship, $\dot{K} = I$. Finally, labor is perfectly mobile across sectors and the labor market always clears, so that the following equation holds at all times:⁶

$$L_T + L_N = 1 \tag{1f}$$

The agent's decisions are to choose his consumption levels C_T , C_N , labor allocation L_T , L_N , the rate of investment I , the capital allocation decisions K_T and K_N , and his rate of accumulation of traded bonds to maximize the following intertemporal utility function

$$\int_0^{\infty} U(C_T, C_N) e^{-\beta t} dt \tag{2}$$

subject to the constraints (1a) – (1f), and given initial stocks $K_T(0) = K_{T,0}$, $K_N(0) = K_{N,0}$, and $B(0) = B_0$. The instantaneous utility function is assumed to be concave and the two consumption goods are assumed to be normal goods. The agent's rate of time preference, β , is taken to be constant.

Letting λ be the shadow value of wealth in the form of internationally traded bonds, q_1 , q_2 may be interpreted as the market prices of the traded and nontraded capital respectively.⁷ The optimality conditions are thus:

$$U_T(C_T, C_N) = \lambda \tag{3a}$$

$$U_N(C_T, C_N) = \lambda \sigma \tag{3b}$$

$$F_L(K_T, L_T) = \sigma H_L(K_N, L_N) \tag{3c}$$

$$\frac{X}{K_N} = \frac{(q_1 - q_2)}{q_2 h} \tag{3d}$$

$$\sigma = q_2 \tag{3e}$$

⁶ The assumption that labor can move costlessly across sectors, while less objectionable than perfect sectoral capital mobility, is also restrictive, since in reality this will involve labor retraining costs; see Dixit and Rob (1994). The presence of sunk costs in their model generates hysteresis in the movement of labor across sectors.

⁷ Writing the Lagrange multipliers associated with the accumulation equations (1b), (1c), λ'_1, λ'_2 say, in the multiplicative form $\lambda'_1 = q_1 \lambda$, $\lambda'_2 = q_2 \lambda$ renders q_1, q_2 unit-free (like the Tobin q)

$$\beta - \frac{\dot{\lambda}}{\lambda} = r \quad (3f)$$

$$\frac{F_K}{q_1} + \frac{\dot{q}_1}{q_1} = r \quad (3g)$$

$$H_K + \frac{hX^2}{2K_N^2} + \frac{\dot{q}_2}{q_2} = r \quad (3h)$$

together with the transversality conditions

$$\lim_{t \rightarrow \infty} \lambda B e^{-\beta t} = \lim_{t \rightarrow \infty} q_1 \lambda K_T e^{-\beta t} = \lim_{t \rightarrow \infty} q_2 \lambda K_N e^{-\beta t} = 0 \quad (3i)$$

Equations (3a) - (3c) are standard static efficiency conditions. Equation (3d) determines the rate at which capital is being transferred between the two sectors. Capital flows from the sector where it is less valued to the sector where it is more valued, at a rate that is inversely related to the size of the adjustment cost parameter, h . Since nontraded output can be either converted into capital or consumed, in equilibrium the agent should be indifferent between these two uses of new output. This yields the equality of the marginal utility of consumption of nontraded goods, $\lambda \sigma$, and the shadow value of capital, $q_2 \lambda$, in the nontraded sector, and reduces to equation (3e).

The remaining three equations are intertemporal efficiency conditions. Equation (3f) equates the rate of return on consumption to the rate of return on traded bonds. To obtain a well-defined interior steady state, we require $\beta = r$ which implies that $\dot{\lambda} = 0$ for all t , so that the marginal utility λ remains constant at all times, i.e., $\lambda = \bar{\lambda}$.⁸ Equations (3g) and (3h) equate the rates of return on traded and nontraded capital to the rate of return on traded bonds. Both include the “payout rate” (the appropriately valued marginal physical product) plus the rate of capital gain. In addition, since increasing the stock of nontraded capital reduces the adjustment costs, this comprises a third component of the rate of return to nontraded capital.⁹

The government in this economy is passive. It simply raises lump-sum taxes to finance its expenditures on the traded and nontraded good, G_T and G_N , respectively, in accordance with

⁸ This assumption is standard in deriving intertemporal models of small open economies, although it is not particularly appealing. Its consequences for the equilibrium dynamics are discussed by Turnovsky (1997) in some detail.

⁹ Note that in the absence of sectoral adjustment costs, $h = 0$, implying $q_1 = q_2 = \sigma$. Substituting these conditions into (3g) and (3h), the latter reduce to the standard static efficiency condition $F_K = \sigma H_K$.

$T_L = G_T + \sigma G_N$. For simplicity, we assume that the utility government spending provides is additively separable from that yielded by private consumption, so that without any loss of generality it can be ignored.

2.2 Macroeconomic Equilibrium

The macroeconomic equilibrium is obtained as follows. First, we solve equations (3a) and (3b) for traded and nontraded consumption, C_T and C_N , in the form, $C_T = C_T(\bar{\lambda}, \sigma)$, $C_N = C_N(\bar{\lambda}, \sigma)$. From the labor market efficiency condition (3c) and (1f) we may derive, $L_T = L_T(K_T, K_N, \sigma)$, $L_N = L_N(K_T, K_N, \sigma)$. The macroeconomic equilibrium can thus be summarized by the following autonomous system in the four variables, K_T, K_N, σ, X

$$\dot{K}_T = X \quad (4a)$$

$$\dot{K}_N = H(K_N L_N(K_T, K_N, \sigma)) - C_N(\bar{\lambda}, \sigma) - X \left(1 + \frac{hX}{2K_N} \right) - G_N \quad (4b)$$

$$\dot{\sigma} = \sigma \left(r - H_K(K_N L_N(K_T, K_N, \sigma)) - \frac{hX^2}{2K_N^2} \right) \quad (4c)$$

$$\dot{X} = \left(\frac{H(K_N, L_N(K_T, K_N, \sigma)) - C_N(\bar{\lambda}, \sigma) - G_N}{K_N} + H_K(K_N, L_N(K_T, K_N, \sigma)) \right) X - \frac{X^2}{2K_N} - \frac{K_N}{h\sigma} \left[F_K(K_T, L_T(K_T, K_N, \sigma)) - \sigma H_K(K_N, L_N(K_T, K_N, \sigma)) \right] \quad (4d)$$

together with the current account condition

$$\dot{B} = F(K_T, L_T(K_T, K_N, \sigma)) - C_T(\bar{\lambda}, \sigma) + rB - G_T \quad (4e)$$

2.3 Steady State and Equilibrium Dynamics

The economy reaches steady state when $\dot{K}_T = \dot{K}_N = \dot{\sigma} = \dot{X} = \dot{B} = 0$, implying further that in steady state, $X = 0$. Imposing these conditions yields the steady-state relationships

$$\frac{F_K(\tilde{K}_T, L_T(\tilde{K}_T, \tilde{K}_N, \tilde{\sigma}))}{\tilde{\sigma}} = r \quad (4d')$$

$$H_K(\tilde{K}_N, L_N(\tilde{K}_T, \tilde{K}_N, \tilde{\sigma})) = r \quad (4c')$$

$$F(\tilde{K}_T, L_T(\tilde{K}_T, \tilde{K}_N, \tilde{\sigma})) = C_T(\bar{\lambda}, \tilde{\sigma}) + G_T - r\tilde{B} \quad (4e')$$

$$H(\tilde{K}_N, L_N(\tilde{K}_T, \tilde{K}_N, \tilde{\sigma})) = C_N(\bar{\lambda}, \tilde{\sigma}) + G_N \quad (4b')$$

Linearizing (4a) – (4d) around the steady state (denoted by tildes), the dynamics of K_T , K_N , σ , and X can be approximated by

$$\begin{pmatrix} \dot{K}_T \\ \dot{K}_N \\ \dot{\sigma} \\ \dot{X} \end{pmatrix} = \begin{pmatrix} 0 & 0 & 0 & 1 \\ a_{21} & a_{22} & a_{23} & -1 \\ a_{31} & a_{32} & a_{33} & 0 \\ a_{41} & a_{42} & a_{43} & H_K \end{pmatrix} \begin{pmatrix} K_T - \tilde{K}_T \\ K_N - \tilde{K}_N \\ \sigma - \tilde{\sigma} \\ X - \tilde{X} \end{pmatrix} \quad (5)$$

where

$$\begin{aligned} a_{21} &= H_L \frac{\partial L_N}{\partial K_T}; a_{22} = H_K + H_L \frac{\partial L_N}{\partial K_N}; a_{23} = H_L \frac{\partial L_N}{\partial \sigma} - \frac{\partial C_N}{\partial \sigma}; \\ a_{31} &= -\sigma H_{KL} \frac{\partial L_N}{\partial K_T}; a_{32} = -\sigma \left(H_{KK} + H_{KL} \frac{\partial L_N}{\partial K_N} \right); a_{33} = -\sigma H_{KL} \frac{\partial L_N}{\partial \sigma}; \\ a_{41} &= -\frac{K_N}{h} \left(\frac{1}{\sigma} \left[F_{KK} + F_{KL} \frac{\partial L_T}{\partial K_T} \right] - H_{KL} \frac{\partial L_N}{\partial K_T} \right); \\ a_{42} &= -\frac{K_N}{h} \left(\frac{1}{\sigma} F_{KL} \frac{\partial L_T}{\partial K_N} - \left[H_{KK} + H_{KL} \frac{\partial L_N}{\partial K_N} \right] \right); a_{43} = -\frac{K_N}{h} \left(-\frac{F_K}{\sigma^2} + \frac{F_{KL}}{\sigma} \frac{\partial L_T}{\partial \sigma} - H_{KL} \frac{\partial L_N}{\partial \sigma} \right); \end{aligned}$$

Equation (5) describes a fourth-order linear dynamic system, and by examining its characteristic equation we can establish that there are two eigenvalues having positive real parts and two with negative real parts, implying that the equilibrium is a saddlepoint.¹⁰ We assume that the two capital stocks, K_T and K_N , are constrained to move sluggishly, while the relative price, σ , and the rate of intersectoral capital transfer, X , are free to jump instantaneously, so that the equilibrium yields a unique stable saddlepath.

In most our numerical simulations, the eigenvalues are real, although pairs of complex

¹⁰See Morshed and Turnovsky (2004).

eigenvalues frequently occur as well. Focusing on the former case, we denote the stable eigenvalues by μ_1 and μ_2 , with $\mu_2 < \mu_1 < 0$, so that the (linearized) stable solutions may be written in the form:

$$K_T - \tilde{K}_T = D_1 e^{\mu_1 t} + D_2 e^{\mu_2 t} \quad (6a)$$

$$K_N - \tilde{K}_N = D_1 v_{21} e^{\mu_1 t} + D_2 v_{22} e^{\mu_2 t} \quad (6b)$$

$$\sigma - \tilde{\sigma} = D_1 v_{31} e^{\mu_1 t} + D_2 v_{32} e^{\mu_2 t} \quad (6c)$$

$$X - \tilde{X} = D_1 v_{41} e^{\mu_1 t} + D_2 v_{42} e^{\mu_2 t} \quad (6d)$$

where the vector $(1 \ v_{2i} \ v_{3i} \ v_{4i})'$ $i = 1, 2$ (and the prime denotes vector transpose) is the normalized eigenvector associated with the stable eigenvalue, μ_i , and the constants D_1 and D_2 , obtained by considering (6a) and (6b) at $t = 0$, are given by

$$D_1 = \left[(\tilde{K}_N - K_{N,0}) - v_{22} (\tilde{K}_T - K_{T,0}) \right] / (v_{22} - v_{21}); \quad D_2 = \left[-(\tilde{K}_N - K_{N,0}) + v_{21} (\tilde{K}_T - K_{T,0}) \right] / (v_{22} - v_{21})$$

These depend upon the changes in the steady-state capital stocks and thus the specific shocks.

The key issue we wish to discuss concerns the rate of convergence of $\sigma(t)$, the rate at which the real exchange rate adjusts to its new steady state, following some shock. We shall define this as

$$\kappa(t) \equiv \frac{\dot{\sigma}(t)}{\tilde{\sigma} - \sigma(t)} = \left(\frac{D_1 v_{31} e^{\mu_1 t}}{D_1 v_{31} e^{\mu_1 t} + D_2 v_{32} e^{\mu_2 t}} \right) (-\mu_1) + \left(\frac{D_2 v_{32} e^{\mu_2 t}}{D_1 v_{31} e^{\mu_1 t} + D_2 v_{32} e^{\mu_2 t}} \right) (-\mu_2) \quad (7)$$

which is a time-varying weighted average of the negatives of the two eigenvalues.¹¹ Initially,

$$\kappa(0) = \left(\frac{D_1 v_{31}}{D_1 v_{31} + D_2 v_{32}} \right) (-\mu_1) + \left(\frac{D_2 v_{32}}{D_1 v_{31} + D_2 v_{32}} \right) (-\mu_2)$$

and asymptotically, $\kappa(t) \rightarrow \tilde{\kappa} \equiv -\mu_1 > 0$. In our numerical simulations we shall study how $\kappa(0), \tilde{\kappa}$ depend upon the sectoral elasticities of substitution, as the economy evolves in response to alternative shocks.

¹¹ This definition is chosen so as to ensure that as long as $\sigma(t)$ is approaching $\tilde{\sigma}$, the rate of convergence $\kappa(t) > 0$.

In the cases the stable eigenvalues come in complex conjugate pairs, $\mu_1, \mu_2 = \alpha \pm i\beta$, with corresponding complex eigenvectors $v \pm iw$, the solution for a variable is of the general form

$$z(t) = \tilde{z} + A_1(v + iw)e^{(\alpha+i\beta)t} + A_2(v - iw)e^{(\alpha-i\beta)t}$$

where A_1, A_2 are arbitrary constants, implying cyclical behavior with periodicity $2\pi/\beta$. In the case of the real exchange rate, (6c) and (7), respectively, are thus modified to

$$\sigma - \tilde{\sigma} = e^{\alpha t} [(D_1 v_{31} - D_2 w_{31}) \cos(\beta t) - (D_1 w_{31} + D_2 v_{31}) \sin(\beta t)] \quad (6c')$$

$$\kappa(t) \equiv \frac{\dot{\sigma}(t)}{\tilde{\sigma} - \sigma(t)} = \frac{(D_1 w_{31} + D_2 v_{31})(\alpha \sin(\beta t) + \beta \cos(\beta t)) - (D_1 v_{31} - D_2 w_{31})(\alpha \cos(\beta t) - \beta \sin(\beta t))}{(D_1 v_{31} - D_2 w_{31}) \cos(\beta t) - (D_1 w_{31} + D_2 v_{31}) \sin(\beta t)} \quad (7')$$

Because the transitional path oscillates about its steady state, the measure of convergence (7') is potentially inconvenient because it becomes infinite each time $\sigma(t)$ cycles through its equilibrium value, $\tilde{\sigma}$. In this case a more appropriate measure of the rate of convergence is the modulus of the roots, $r = \sqrt{\alpha^2 + \beta^2}$, which is constant over time. However, since it turns out that the periodicity is very long, the cycles in fact occur only very close to the new equilibrium, and indeed to a first approximation, the economy appears to evolve as if the roots were real.¹² Accordingly, we can for practical purposes employ the definition (7'), and we adopt the modulus measure only during the latter stages (including asymptotically) when the oscillations eventually prevail and would otherwise distort the measure.

3. Calibration

To conduct the numerical analysis we adopt the following explicit utility and production functions:

$$\text{Utility Function: } U = \frac{1}{\gamma} (C_T^\theta C_N^{1-\theta})^\gamma \quad 0 < \theta < 1; \quad -\infty < \gamma < 1 \quad (8a)$$

$$\text{Production Functions: } F(K_T, L_T) = \phi [mK_T^{-\alpha} + (1-m)L_T^{-\alpha}]^{\frac{1}{\alpha}}$$

¹² Depending upon the shock, the periodicity is often of the order of 80-100 years. Examples of this are seen in Fig. 2 below

$$H(K_N, L_N) = \psi [nK_N^{-\delta} + (1-n)L_N^{-\delta}]^{-\frac{1}{\delta}} \quad (8b)$$

$$\phi > 0, \psi > 0, 0 < m < 1, 0 < n < 1$$

Since our objective is to study the role of the elasticity of factor substitution in determining the dynamics, we have chosen the CES production functions for both the traded goods and nontraded goods sectors. Thus $s_T \equiv 1/(1+\alpha)$ and $s_N \equiv 1/(1+\delta)$ define the (constant) elasticities of substitution for production in the two sectors, respectively. The Cobb-Douglas production functions are obtained by letting $\alpha \rightarrow 0, \delta \rightarrow 0$. The coefficients ϕ and ψ parameterize the productivity in the traded and nontraded good sector respectively, while m and n parameterize the respective capital intensities in the two sectors. Since the behavior of the economy is sensitive to the relative sectoral capital intensities, we will identify two benchmark equilibria, depending upon whether the traded sector is more capital intensive than is the nontraded sector ($m > n$) or vice versa ($n > m$).

Table 1.A reports base parameter values, while Table 1.B reports the corresponding key steady-state equilibrium ratios. With the exception of the elasticity of substitution, which we allow to vary, these are identical to the parameter values chosen by Morshed and Turnovsky (2004) where they are explained and discussed in detail. Most of the chosen parameter values are standard and non-controversial, and well within the range of consensus empirical estimates. As we also discuss in the earlier paper, the resulting steady-state equilibrium values are all plausible. The quantities pertaining to the breakdown between the traded and non-traded sector are not particularly well documented in the literature, but these have been derived as averages for some 30 trading economies; see Morshed and Turnovsky (2004). That study was based on the Cobb-Douglas production function. Here we also treat that as the benchmark, but also allow the elasticities of substitution to take on the values 0.67 (low) and 1.33 (high).

The other critical parameter only differences are in the productivity elasticities. In the first case, $m = 0.35, n = 0.25$, the capital intensity of the traded sector exceeds that of the nontraded sector; in the second case, $m = 0.25, n = 0.35$, the relative sectoral intensities are reversed. The reason for keeping the productive elasticities within this narrow range is that they reflect the share of capital in the respective output of that sector. Since both the traded and nontraded sectors

themselves represent substantial aggregates, we would not expect their production functions to differ too dramatically from the overall aggregate, for which the elasticity of capital typically is in the above ranges.

In Morshed and Turnovsky (2004) our primary concern was to investigate the sensitivity of the transitional path to the adjustment cost parameter h , and we let range h from 0 to $h = 1000$ thus spanning the frictionless Heckscher-Ohlin technology and the specific factor technology as polar cases. On the basis of empirical evidence (sparser and less direct in the case of sectoral adjustment costs) we took $h = 30$ as the benchmark value and we retain that value in this study.¹³

4. Dynamics of Real Exchange Rate

4.1 Some analytical relationships

Tables 2 and 3, and Figs. 1 and 2 summarize various aspects of the dynamic adjustment of the real exchange rate in response to various underlying shocks. To understand fully the transitional dynamics we need to consider all these aspects, including the short-run and long-run forces determining the real exchange rate. To pursue this we must focus on certain critical components of the equilibrium.

Consider first the steady state. As is well known, the long-run equilibrium real exchange rate is determined solely from the supply side of the system. Given the linear homogeneity of the underlying production functions, this can be conveniently summarized by the three equations expressed in terms of the standard intensive quantities [i.e. f, g are in sectoral per capita terms]¹⁴

$$\psi h'(\tilde{k}_N) = r \tag{9a}$$

$$\phi f'(\tilde{k}_T) = r\tilde{\sigma} \tag{9b}$$

$$\phi \left[f(\tilde{k}_T) - k_T f'(\tilde{k}_T) \right] = \tilde{\sigma} \psi \left[h(\tilde{k}_N) - k_N h'(\tilde{k}_N) \right] \tag{9c}$$

¹³ We did experiment with other values of h , but our conclusions remain largely unaffected.

¹⁴ Since the sectoral adjustment costs being studied in this paper occur only during the transition, they do not affect the steady state, which is identical to that of the frictionless economy, studied by Turnovsky and Sen (1995).

where \sim denotes the steady state. These equations, which include the productivity terms ϕ, ψ explicitly, are the counterparts to (4c'), (4d'), and (3c). They jointly determine the long-run equilibrium values of the sectoral capital labor ratios, $k_T \equiv K_T/L_T$, $k_N \equiv K_N/L_N$, together with σ .

From these equations we can immediately derive

$$\frac{d\tilde{\sigma}}{dG_T} = \frac{d\tilde{\sigma}}{dG_N} = 0 \quad (10a)$$

$$\frac{d\tilde{\sigma}}{d\phi} \frac{\phi}{\tilde{\sigma}} = 1 \quad (10b)$$

$$\frac{d\tilde{\sigma}}{d\psi} \frac{\psi}{\tilde{\sigma}} < 0; \quad \frac{d\tilde{\sigma}}{d\psi} \frac{\tilde{\psi}}{\tilde{\sigma}} = -1 + \frac{h'(\tilde{k}_T - \tilde{k}_N)}{[h(\tilde{k}_N) - h(\tilde{k}_N - \tilde{k}_T)]} \quad (10c)$$

Thus, in the long-run the real exchange rate is independent of either form of government expenditure. A 1% increase in the productivity in the traded sector leads to a 1% increase in the long-run real exchange depreciation. A productivity increase in the non-traded sector leads to a long-run real appreciation, though whether it is more than, or less than, proportionate or not depends upon the equilibrium sectoral relative capital-labor ratios.¹⁵

The other relationships that help in the interpretation of the short-run adjustment in the exchange rate are the short-run labor allocation relationship and the market-clearing condition in the non-traded sector, namely

$$\phi F_L(K_T, L_T) = \sigma \psi H_L(K_N, L_N) \quad (11a)$$

$$\psi H(K_N, L_N) = C(\bar{\lambda}, \sigma) + I + G_N \quad (11b)$$

with the capital stocks being slow to adjust sectors on impact, these two equations imply

$$\frac{d\sigma(0)}{\sigma} = \frac{d\phi}{\phi} - \frac{d\psi}{\psi} - \left(\frac{\phi F_{LL} + \sigma \psi H_{LL}}{\phi F_L} \right) dL_N(0) \quad (12a)$$

$$\psi H_L dL_N(0) = dC(0) - Hd\psi + dG_N \quad (12b)$$

¹⁵ This is essentially the Balassa-Samuelson effect.

These two equations bring out two factors important for understanding the short-run adjustment of the exchange rate. First, (12a) identifies how the short-run adjustment involves a tradeoff between (i) the exchange rate, and (ii) the movement of labor across sectors. Using the fact implied by the homogeneity of the production function that (i) $F_{LL} = -KF_{KL}/L$, and that the elasticity of substitution can be expressed as $s_T = -F_L F_K / F_{KL} F$, and similarly for H , we can rewrite (12a) in the form

$$\frac{d\sigma(0)}{\sigma} = \frac{d\phi}{\phi} - \frac{d\psi}{\psi} + \left(\frac{\omega_{T,K}}{s_T} + \frac{\omega_{N,K}}{s_N} \right) \frac{dL_N(0)}{L_N(0)} \quad (13)$$

where $\omega_{T,K}$, $\omega_{N,K}$ denote the share of capital in the traded and nontraded sectors, respectively. The short-run response of the exchange rate can be broken down as follows. The direct effect of a 1% increase in productivity in the traded (nontraded) sector is to cause a 1% depreciation (appreciation) of the exchange rate. The secondary effect operates through the short-run sectoral labor adjustment. Given the share of capital, this varies inversely with the elasticity of substitution in either sector, as our numerical simulations below will confirm, this tradeoff is highly influenced by the elasticity of substitution in production. Second, (12b) implies that the sectoral labor movement is constrained by the clearance of the nontraded goods market. Thus introduces an asymmetry between shocks originating in the traded sector and those in the nontraded sector, where the labor market effect operates more directly.

Finally, from the definition of the rate of convergence, κ , given in (7) we see that a larger initial jump in $\sigma(0)$ will tend to lead to a faster initial rate of convergence. Consequently, its response to changes in the elasticities of substitution will mirror that of $\sigma(0)$.

4.2 Some General Observations: Short-and Long-run responses of the exchange rate

Table 1 summarizes the short-run and long-run elasticities of the real exchange rate in response to the two government expenditure shocks, G_T, G_N , and the two productivity shocks, ϕ, ψ . The array lists the responses as the elasticities of substitution in the two sectors increase from 0.67 (low) to 1 (medium) to 1.33 (high).

Government Expenditure: The long-run responses to both types of increase in government expenditure are zero, consistent with (10a).

The short-run effect of a (lump-sum tax-financed) increase in G_T is to reduce wealth, reducing private consumption, thus increasing employment in the traded sector, thereby reducing $L_N(0)$ and causing the real exchange rate to appreciate. The higher the elasticity of substitution, the more the adjustment is borne by the reduction in employment, and the less by the real exchange rate. Thus as s_N and s_T increase from 0.67 to 1.33, the initial elasticity declines from -0.025 to -0.009, with the responses being comparable, independent of the relative capital intensities of the two sectors.

By contrast, a short-run increase in G_N has a direct positive effect on demand for the non-traded good. As long as the negative wealth effect on consumption is not too large, the net effect is to raise the total demand for the non-traded good, thus increasing $L_N(0)$, causing the real exchange rate to depreciate. Moreover, because government expenditure impacts directly on demand, the employment effect is larger than is the case for G_T , leading to a correspondingly larger depreciation. Thus, in the case of the Cobb-Douglas production function, the elasticity of the real interest rate is over 0.1. Again, the initial response of the real exchange rate declines as s_T, s_N increase, as more of the adjustment is shifted to employment.

Productivity shocks: A productivity increase in the traded sector causes a proportionate long-run depreciation of the real exchange rate, consistent with (10b). In the short run the increase in productivity in the traded sector raises consumption of both goods, including the nontraded good, raising employment in the nontraded sector, as implied by (12b). This increase in employment in the nontraded sector causes further mild contractionary pressure on the real exchange rate, so that in the short-run σ increases more than proportionately, its elasticity being of the order of 1.02. Again, the short-run response in the exchange rate is mitigated with higher elasticities of substitution, though only slightly.¹⁶

¹⁶An exception is if $s_T = 0.67$ and $n > m$, when as s_T increases from 1 to 1.33, the short-run elasticity actually increases from 1.027 to 1.035.

A productivity increase in the nontraded sector causes a long-run appreciation of the real exchange rate, as implied by (10c). Whether this is more or less than proportionate depends upon whether in equilibrium the capital-labor ratio in the traded sector is less than or greater than in the nontraded sector. In the case where $m > n$, so that the traded sector is more capital intensive, we find $\tilde{k}_T > \tilde{k}_N$, and the appreciation is less than proportionate. However, if $n > m$, then typically (but not always) $\tilde{k}_N > \tilde{k}_T$ and the appreciation is more than proportionate. The long-run response is highly sensitive to the elasticities of substitution, increasing (in magnitude) with s_N , but decreasing with s_T .

The short-run response of the exchange rate is always less than proportional to the productivity increase. This is because the productivity increase both raises wealth and consumption of the nontraded good, thus raising demand, doing so by an amount that exceeds the increase in supply due to the productivity gain. There is net excess demand, necessitating an increase in employment in the nontraded sector. This shift in employment from the traded to the nontraded sector leads to a depreciation of the real exchange rate, offsetting the direct appreciation. Again, the short-run response is highly sensitive to the elasticity of substitutions. Indeed we see that if $s_T = s_N = 1.33$, that if $n > m$ the employment effect dominates and the short-run exchange rate actually depreciates, its elasticity being 0.72, although its long-elasticity is -1.28, indicating a strong long-run depreciation. This is because the share of capital increases sufficiently to offset the declining effect of the higher elasticity of substitution in (13).

In this case, the elasticities of substitution lead to sharp contrasts between the short-run and long-run responses of the real exchange rate. Focusing on the case where the nontraded sector is more capital intensive, we see that if $s_T = s_N = 0.67$, the short-run and long-run elasticities of the real exchange rate are -0.72 and -0.96 ; if $s_T = s_N = 1.33$, these change dramatically to $+0.72$ and -1.28 , respectively.

5. Speeds of Convergence

We now turn to the transitional dynamics of the real exchange rate. Table 3 summarizes our measures of the speed of convergence, both in the short run [at time 0, following any initial jump in

the exchange rate], and as the economy approaches its new equilibrium, asymptotically. We should note that in some cases [indicated in italics] the corresponding eigenvalues are complex, indicating oscillatory adjustment paths. In all cases, however, the periodicities are very long, implying that the oscillations in fact occur after something like 100 periods (depending upon the shock), when the exchange rate is close to its new equilibrium. In these cases, we measure the short-run rate of convergence by (7') and the asymptotic speed by the modulus, for the reason discussed in Section 3.

The figures illustrate the speed of convergence from two different aspects. In Figure 1 we draw examples of time paths for $\sigma(t)$ following a shock. We illustrate these for varying magnitudes of the elasticity of substitution. On the other hand, in Fig. 2 we plot the time paths for the actual rates of convergence, $\kappa(t) \equiv -\dot{\sigma}(t)/(\sigma(t) - \tilde{\sigma})$. In discussing these simulations, we shall begin with a number of general observations, trying to identify patterns among the responses, before focusing on specific shocks.

5.1 General observations

From Table 3 the following patterns can be detected:

(i) *Cobb-Douglas production function*: For the benchmark Cobb-Douglas function, the asymptotic speed of convergence is always slower than the short-run speed of convergence. In the case of G_T, G_N, ϕ , the short-run rates of convergence are all around 5-6%, and they tend to be marginally larger if $n > m$, so that the nontraded sector is relatively capital intensive. The short-run speed of convergence is substantially larger in the case of the nontraded productivity shock, ψ , and furthermore in this case it is substantially higher when the traded sector is relatively capital intensive (19.5% versus 12.3%). The asymptotic speeds of convergence are uniform with respect to all four shocks, being around 2% if $m > n$ and around 5%, when the capital intensity is reversed.

(ii) *Sensitivity to elasticity of substitution*: Both the short-run and long-run speeds of convergence are sensitive to the elasticity of substitutions in both sectors. Allowing the elasticities of substitution to decline by 0.33 relative to the Cobb-Douglas production function leads to a doubling of the rate of convergence; increasing the elasticities of substitution by 0.33 leads to an

approximate halving of the rate of convergence. The corresponding changes to the asymptotic speeds of convergence are smaller, though still substantial. For all shocks, the short-run and long-run speeds of convergence decrease with uniform increases in the two elasticities of substitution (i.e. where both increase together). Overall, these patterns are consistent with the empirical evidence suggesting that developing countries, having smaller elasticities of substitution in production, have more rapidly adjusting real exchange rates. They are also consistent with the relationships (12) and (13).

(iii) *Short-run versus long-run speeds of convergence:* In most cases, the asymptotic speed of convergence is slower than the short-run speed of convergence, consistent with (7), where the speed of convergence is a positively weighted average of the two eigenvalues. There are exceptions, however. These mostly occur when there are complex eigenvalues, leading to cyclic behavior in which the asymptotic speed of convergence is given by the modulus. This occurs mostly if $n > m$ and $s_N = 1.33$.

(iv) *Sensitivity to sources of shocks:* The short-run speeds of convergence are highly sensitive to the sources of the shocks; the long-run rates of convergence are much less so. The sensitivity generally decreases with increases in the elasticity of substitution, suggesting that less developed countries are likely to have speeds of convergence that are more sensitive to the underlying shocks they face.

5.2 Graphical Illustrations

Graphical illustrations of some of these characteristics can be seen from Figs. 1 and 2. The two panels of Fig. 1.A, B graph the time path for $\sigma(t)$ in response to increases in the two types of government expenditures, in the case that the traded good is more capital intensive ($m > n$). In both cases, the real exchange rate jumps from its unchanging steady-state equilibrium [down in the case of G_T , up in the case of G_N] to the equilibrium path which it then follows back to the steady state. These figures show that the diminishing slope of the time path for $\sigma(t)$ implies that the rate of convergence is gradually diminishing over time. Moreover as the elasticity of substitution increases

over time it is clear that the locus in each case has less curvature, implying that the rate of convergence is slower. In the case where $n > m$ [not illustrated], the same general characteristics apply, except that for $s_T = s_N = 1.33$, the time paths have a slight hump after something over 100 years, as the path for $\sigma(t)$ overshoots its long-run equilibrium. The implications of this for the speeds of convergence are illustrated more dramatically in Fig. 2.

Fig. 1.C and D illustrates the time paths in response to the productivity shocks. The time path following the traded shock is generally similar to that following the increase in nontraded government expenditure. This mirrors the numerical responses reported in Tables 3A and 3B. The response to the productivity increase in the nontraded sector is substantially different. In all cases, the time path for $\sigma(t)$ overshoots its long-run response during the transition. As the elasticity of substitution decreases, the overshooting occurs earlier during the transition.

Fig. 2 illustrates the time paths for $\kappa(t)$, the speed of convergence. Fig. 2.A confirms the paths in Fig. 1, though from a different perspective. Thus, we see that as the elasticities of substitution increase from 0.67, through 1, to 1.33, the rates of convergence decline uniformly in the case of both government expenditure shocks and the productivity of the traded good. The response to the productivity increase in the nontraded good is markedly different. It initially increases uniformly, becoming infinite at the point that the exchange rate overshoots its long-run equilibrium during the transition. As the elasticity of substitution increases, the point of time at which this overshooting occurs is delayed.

In Fig. 2.B the nontraded sector is more capital intensive. In this case a high elasticity of substitution always leads to eventual overshooting, for all shocks, at which point the rate of convergence becomes infinite.

5.3 Sensitivity to different underlying shocks

We return to Table 3 to investigate the sensitivity of the short-run and long-run speeds of convergence in response to various structural changes. The patterns we have detected may be summarized as follows:

5.3.1 Increase in G_T :

1 The short-run speed of convergence *decreases* with the elasticity of substitution in the non-traded sector, s_N . The long-run speed of convergence speed *increases* with s_N if the traded sector more capital intensive, although if the non-traded is more capital intensive the relationship is more ambiguous. It increases only if s_T is sufficiently high; for lower values of s_T (<1) it will first increase and then decrease.

2. Both the short-run and long-run rates of convergence are decreasing in s_T .

3. Speeds of convergence are generally higher if the non-traded sector is more capital intensive, although this ceases to be true if s_N is sufficiently high.

4. Short-run speeds of convergence are more sensitive to s_N if the nontraded sector is more capital intensive; long-run speeds of convergence are more sensitive to s_N if the traded sector more capital intensive.

5. Short-run speeds of convergence are more sensitive to s_T if the traded sector more capital intensive. Long-run speeds of convergence are more sensitive to s_T if the nontraded sector is more capital intensive, provided s_N is not too large.

5.3.2 Increase in G_N :

1. The short-run convergence speed decreases with s_N . The long-run convergence speed increases with s_N provided $s_N < 1$. It continues do so for $s_N > 1$ only if s_T is sufficiently large.

2. Both short and long-run rates of convergence are decreasing in s_T .

3. Speeds of convergence are generally higher if the non-traded sector is more capital intensive, though this ceases to be true if s_N is sufficiently high.

4. Short-run speeds of convergence are more sensitive to s_N if the non-traded sector more capital intensive. Long-run speeds of convergence are more sensitive to s_N if the traded sector more capital intensive.

5. Short-run speeds of convergence are more sensitive to s_T if the traded sector more capital intensive. Long-run speeds of convergence are more sensitive to s_T if the non-traded sector is more capital intensive, provided s_N is not too large.

Comparing the responses described in 5.3.1 and 5.3.2, we conclude that short-run speeds of convergence tend to be generally higher in response to G_T than to G_N . Long-run speeds of convergence tend to be generally lower in response to G_T than to G_N . Differences decline when s_N is large.

5.3.3 Increase in ϕ :

1. The short-run speed of convergence decreases with s_N . The relationship between the long-run convergence speed and s_N is rather ambiguous, though it is increasing if both elasticities of substitution are below unity.

2. Both short and long-run rates of convergence are decreasing in s_T .

3. Speeds of convergence are generally higher if the non-traded sector is more capital intensive, though this ceases to be true if s_N is sufficiently high.

4. Short-run speeds of convergence are more sensitive to s_N if non-traded sector more capital intensive. Long-run speeds of convergence are more sensitive to s_N if traded sector more capital intensive.

5. Short-run speeds of convergence are more sensitive to s_T if traded sector more capital intensive. Long-run speeds of convergence are more sensitive to s_T if non-traded sector is more capital intensive, provided s_N is not too large.

5.3.4 Increase in ψ :

1. The short-run speed of convergence decreases with s_N . The long-run convergence speed increases with s_N if traded sector more capital intensive. If non-traded is more capital intensive relationship is more ambiguous. It increases only if s_T is sufficiently high. For lower s_T it will first increase and then decrease.

2. Both short-run and long-run rates of convergence are decreasing in s_T .

3. Short-run speeds of convergence are higher if the traded sector is more capital intensive. This ceases to be true if s_N is sufficiently high.

4. Both the short-run and long-run speeds of convergence are more sensitive to s_N if the traded sector is more capital intensive than when the reverse is the case.

5. Short-run speeds of convergence are relatively insensitive to s_T . Long-run speeds of convergence are more sensitive to s_T if the non-traded sector is more capital intensive, provided s_N is not too large.

Short-run speeds of convergence are much higher in response to ψ than they are to ϕ , though the differences decline as s_N increases. The long-run rates of convergence respond approximately equally to both shocks.

6. Conclusions

The persistence of the deviation of the real exchange rate, measured as a slow speed of convergence, has become an important empirical regularity, one meriting serious analytical study. The fact that the degrees of persistence differ systematically across countries at different stages of development increases the significance of this evidence, as well as the need to understand provide it with some theoretical underpinning.

In a previous paper we showed how the introduction of sectoral adjustment costs in a two-sector model of a small open economy could generate this type of exchange rate persistence. However, that earlier work was based on the restrictive Cobb-Douglas production function. Recent empirical work has suggested that the elasticity of substitution between capital and labor tends to increase from below unity, for less developed economies, to above one for more advanced economies. Generalizing the sectoral technologies to the CES form, we find that as the elasticity of factor substitution of factors increases the deviation of the real exchange rate becomes more persistent. Thus the framework provides a very natural explanation, one that emerges as an equilibrium outcome, of the empirical regularity suggesting that the real exchange rates of developing economies show less persistence than do those of more advanced economies.

Our analysis has also brought out several other aspects of the relationship between the production technologies and the speed of convergence of the real exchange rate. First, there is a sharp contrast between the long and the short-run rates of convergence and how these respond to the elasticity of substitution. Second, there is a sharp contrast between the long-run rate of convergence and between the elasticities of substitution in the two sectors. Third, the rate of convergence is quite sensitive to the source of the underlying shocks, particularly in the short run. This dependence tends to be more acute, as the elasticity of substitution declines. This suggests that developing countries with lower elasticity of substitution in production would be more sensitive to any shock and thus would have more rapidly adjusting real exchange rates. In any event, overall, the flexibility of the sectoral production technologies is a crucial determinant of the real exchange rate dynamics, both in the short run and over time.

Table:1**A. Base Parameter Values**

Preference parameters	$\gamma = -1.5, \theta = 0.5$
Foreign Interest Rate	$r = 0.06$
Productivity	$\phi = 1.5, \psi = 1$
Government Expenditure	$G_T = 0.09, G_N = 0.36$

B. Key Steady-State Equilibrium Ratios

Traded Sector More capital intensive: $m = 0.35, n = 0.25$ $s_T = s_N = 1$										
K_T/L_T	K_N/L_N	K_T/Y_T	K_N/Y_N	K/Y	L_T	Y_T/Y	G_T/G	G_T/Y_T	G_N/Y_N	G/Y
10.83	6.705	3.136	4.167	3.746	0.374	0.408	0.068	0.070	0.358	0.240
Nontraded Sector More capital intensive: $m = 0.25, n = 0.35$ $s_T = s_N = 1$										
K_T/L_T	K_N/L_N	K_T/Y_T	K_N/Y_N	K/Y	L_T	Y_T/Y	G_T/G	G_T/Y_T	G_N/Y_N	G/Y
9.334	15.08	3.560	5.833	4.828	0.477	0.442	0.176	0.072	0.266	0.180

C. Summary Data on Relative Size of Traded and Nontraded Sector

	Range	Unweighted average
Y_T/Y	0.266 - 0.593	0.405
G_T/G	0.011 - 0.173	0.072
G_T/Y_T	0.006 - 0.149	0.040
G_N/Y_N	0.128 - 0.751	0.408
G/Y	0.092 - 0.513	0.262

Table 2**Short-run and Long-run Exchange Rate Elasticities****A. Elasticity with respect to G_T**

		Traded Sector More Capital Intensive			Non-Traded Sector More Capital Intensive		
$s_N \downarrow$	$s_T \rightarrow$	0.67	1.00	1.33	0.67	1.00	1.33
0.67	$\sigma(0)$	-0.025	-0.020	-0.014	-0.028	-0.024	-0.020
1.00	$\sigma(0)$	-0.023	-0.018	-0.012	-0.028	-0.022	-0.016
1.33	$\sigma(0)$	-0.022	-0.016	-0.009	-0.036	-0.022	-0.011
	$\tilde{\sigma}$	0	0	0	0	0	0

B. Elasticity with respect to G_N

		A. Traded Sector More Capital Intensive			B. Non-Traded Sector More Capital Intensive		
$s_N \downarrow$	$s_T \rightarrow$	0.67	1.00	1.33	0.67	1.00	1.33
0.67	$\sigma(0)$	0.173	0.171	0.153	0.146	0.144	0.136
1.00	$\sigma(0)$	0.137	0.133	0.116	0.111	0.103	0.090
1.33	$\sigma(0)$	0.112	0.101	0.082	0.075	0.059	0.041
	$\tilde{\sigma}$	0	0	0	0	0	0

C. Elasticity with respect to ϕ

		A. Traded Sector More Capital Intensive			B. Non-Traded Sector More Capital Intensive		
$s_N \downarrow$	$s_T \rightarrow$	0.67	1.00	1.33	0.67	1.00	1.33
0.67	$\sigma(0)$	1.025	1.020	1.014	1.027	1.024	1.020
1.00	$\sigma(0)$	1.022	1.017	1.012	1.027	1.022	1.016
1.33	$\sigma(0)$	1.022	1.016	1.009	1.035	1.022	1.011
	$\tilde{\sigma}$	1	1	1	1	1	1

D. Elasticity with respect to ψ

		A. Traded Sector More Capital Intensive			B. Non-Traded Sector More Capital Intensive		
$s_N \downarrow$	$s_T \rightarrow$	0.67	1.00	1.33	0.67	1.00	1.33
0.67	$\sigma(0)$	-0.727	-0.593	-0.363	-0.720	-0.625	-0.465
	$\tilde{\sigma}$	-0.861	-0.705	-0.506	-0.957	-0.846	-0.691
1.00	$\sigma(0)$	-0.574	-0.395	-0.103	-0.526	-0.368	-0.108
	$\tilde{\sigma}$	-0.975	-0.793	-0.557	-1.193	-1.041	-0.818
1.33	$\sigma(0)$	-0.373	-0.108	0.315	-0.234	0.088	0.720
	$\tilde{\sigma}$	-1.237	-0.995	-0.674	-2.109	-1.802	-1.277

Table 3
Speeds of Convergence

A. Increase in G_T

$s_N \downarrow$	$s_T \rightarrow$	Traded Sector More Capital Intensive			Non-Traded Sector More Capital Intensive		
		0.67	1.00	1.33	0.67	1.00	1.33
0.67	$\kappa(0)$	0.103	0.081	0.057	0.122	0.107	0.087
	$\tilde{\kappa}$	0.034	0.015	0.007	0.052	0.024	0.012
1.00	$\kappa(0)$	0.070	0.055	0.038	<i>0.072</i>	0.063	0.051
	$\tilde{\kappa}$	0.063	0.022	0.010	<i>0.080</i>	0.047	0.019
1.33	$\kappa(0)$	<i>0.048</i>	<i>0.038</i>	0.027	0.031	<i>0.028</i>	<i>0.023</i>
	$\tilde{\kappa}$	<i>0.065</i>	<i>0.041</i>	0.016	0.050	<i>0.039</i>	<i>0.026</i>

B. Increase in G_N

$s_N \downarrow$	$s_T \rightarrow$	A. Traded Sector More Capital Intensive			B. Non-Traded Sector More Capital Intensive		
		0.67	1.00	1.33	0.67	1.00	1.33
0.67	$\kappa(0)$	0.087	0.069	0.049	0.109	0.096	0.078
	$\tilde{\kappa}$	0.042	0.017	0.008	0.062	0.028	0.014
1.00	$\kappa(0)$	<i>0.062</i>	0.048	0.034	<i>0.069</i>	<i>0.060</i>	0.048
	$\tilde{\kappa}$	<i>0.075</i>	0.026	0.011	<i>0.082</i>	<i>0.055</i>	0.021
1.33	$\kappa(0)$	<i>0.045</i>	<i>0.035</i>	0.025	0.030	<i>0.027</i>	<i>0.022</i>
	$\tilde{\kappa}$	<i>0.066</i>	<i>0.042</i>	0.018	0.050	<i>0.040</i>	<i>0.026</i>

Numbers in italics denotes complex eigenvalues

3.C. Increase in ϕ

		Traded Sector More Capital Intensive			Non-Traded Sector More Capital Intensive		
$s_N \downarrow$	$s_T \rightarrow$	0.67	1.00	1.33	0.67	1.00	1.33
0.67	$\kappa(0)$	0.099	0.079	0.056	0.118	0.105	0.085
	$\tilde{\kappa}$	0.036	0.015	0.007	0.054	0.025	0.012
1.00	$\kappa(0)$	0.068	0.053	0.038	0.071	0.062	0.050
	$\tilde{\kappa}$	0.073	0.022	0.010	0.081	0.053	0.019
1.33	$\kappa(0)$	0.047	0.037	0.026	0.030	0.027	0.022
	$\tilde{\kappa}$	0.065	0.041	0.016	0.050	0.040	0.026

D. Increase in ψ

		A. Traded Sector More Capital Intensive			B. Non-Traded Sector More Capital Intensive		
$s_N \downarrow$	$s_T \rightarrow$	0.67	1.00	1.33	0.67	1.00	1.33
0.67	$\kappa(0)$	0.521	0.686	0.578	0.314	0.367	0.393
	$\tilde{\kappa}$	0.033	0.014	0.006	0.050	0.023	0.011
1.00	$\kappa(0)$	0.183	0.195	0.177	0.115	0.123	0.124
	$\tilde{\kappa}$	0.061	0.021	0.009	0.081	0.044	0.018
1.33	$\kappa(0)$	0.084	0.086	0.079	0.034	0.036	0.038
	$\tilde{\kappa}$	0.065	0.041	0.015	0.041	0.038	0.025

Figure 1: Time Path for Real Exchange Rate
Traded Sector More Capital Intensive

A. Increase in G_T

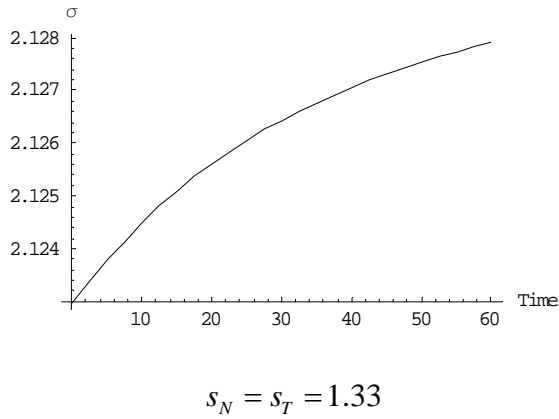
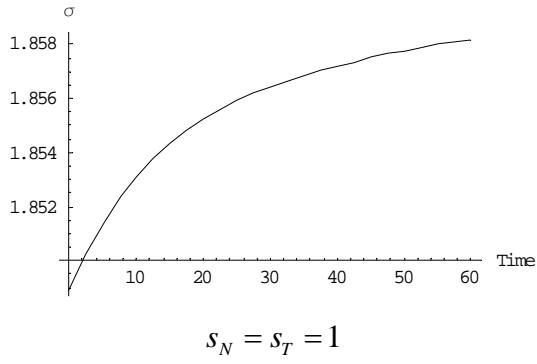
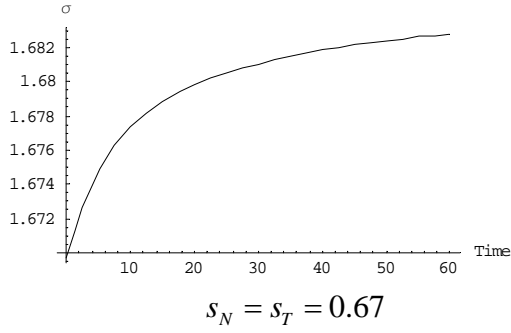

B. Increase in G_N

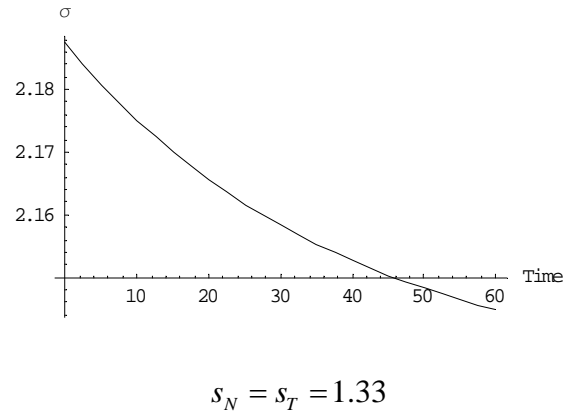
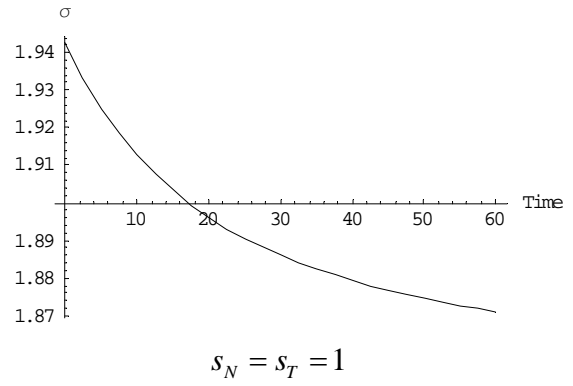
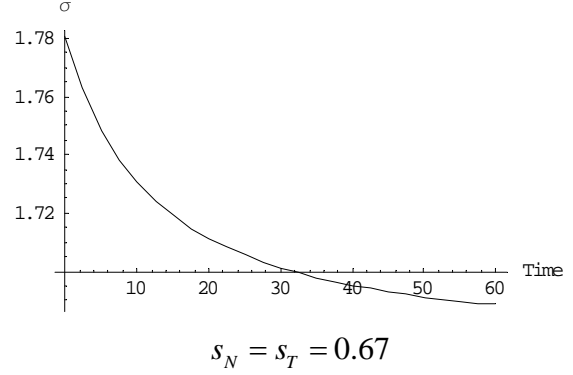

C. Increase in ϕ

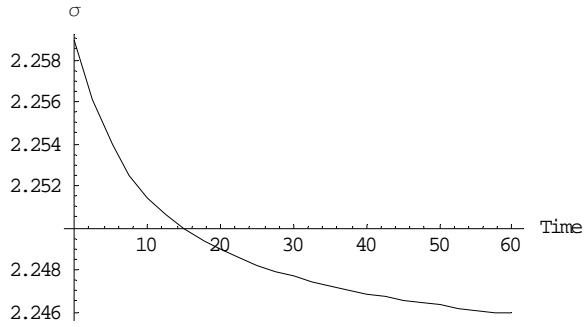

$$s_N = s_T = 0.67$$

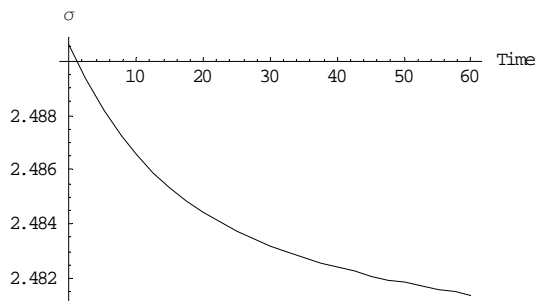

$$s_N = s_T = 1$$

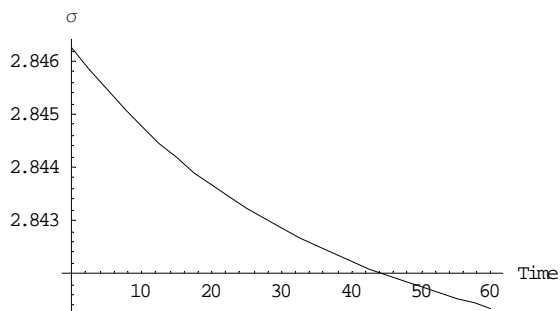

$$s_N = s_T = 1.33$$

D. Increase in ψ

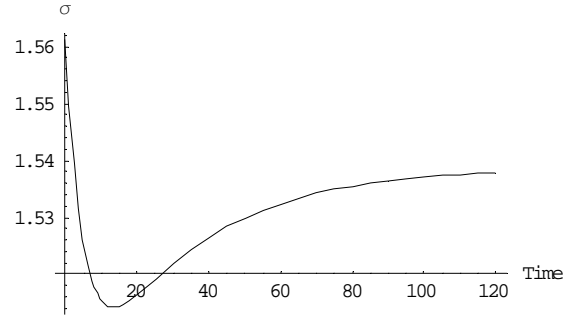

$$s_N = s_T = 0.67$$

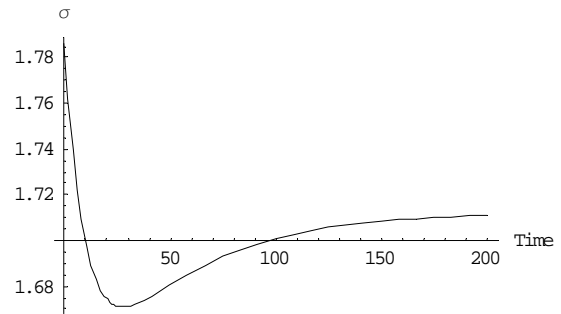

$$s_N = s_T = 1$$

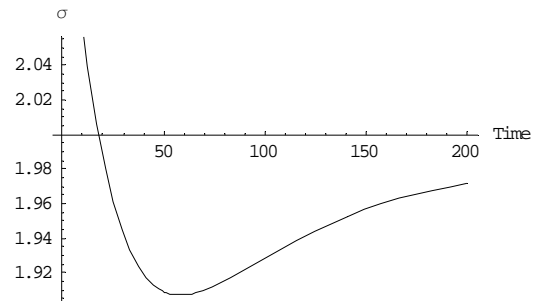

$$s_N = s_T = 1.33$$

Figure 2. Adjustment Speeds

A. Traded Sector More Capital Intensive

A. Increase in G_T

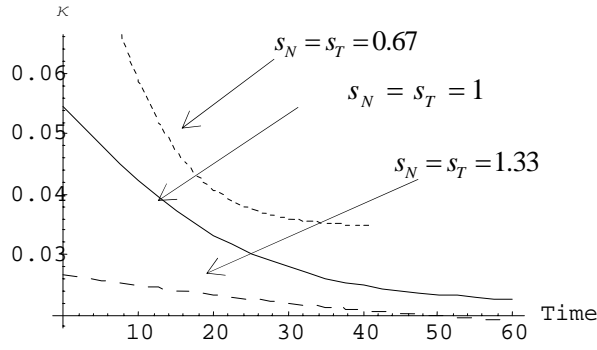

C. Increase in ϕ

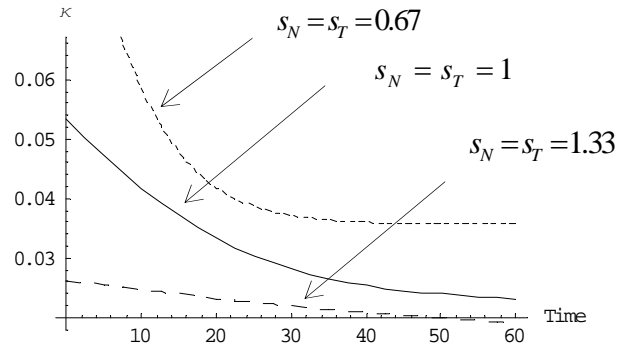

B. Increase in G_N

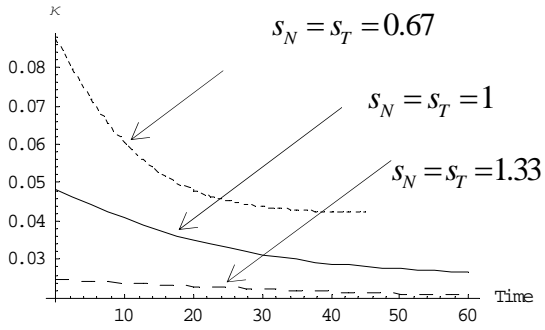

D. Increase in ψ

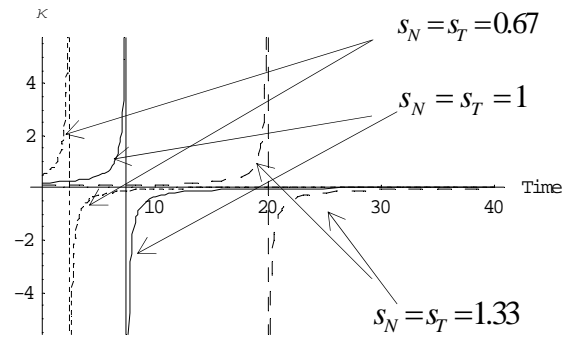

B. Non-Traded Sector More Capital Intensive

A. Increase in G_T

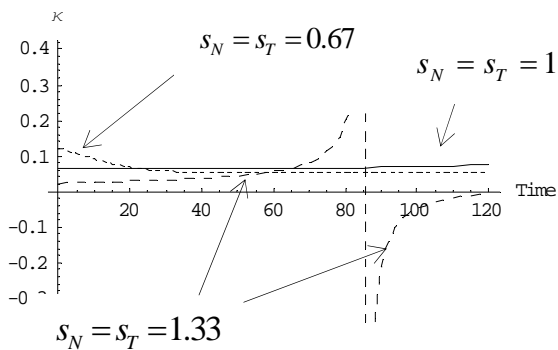

C. Increase in ϕ

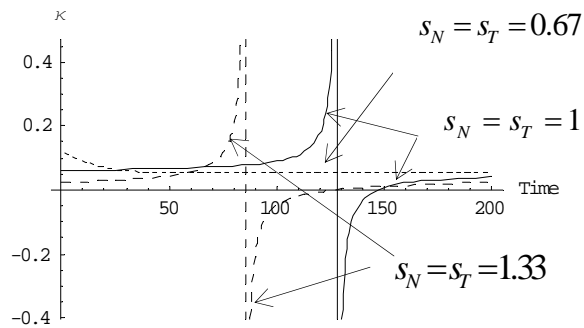

B. Increase in G_N

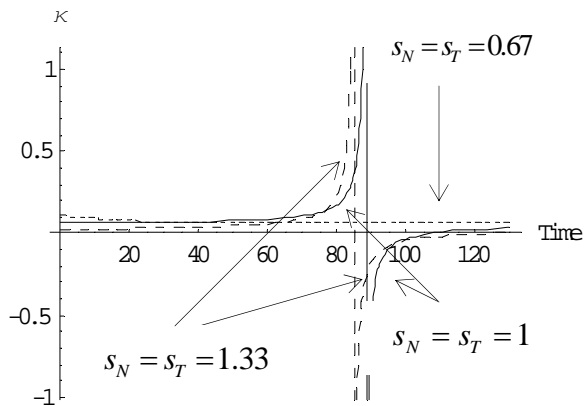

D. Increase in ψ

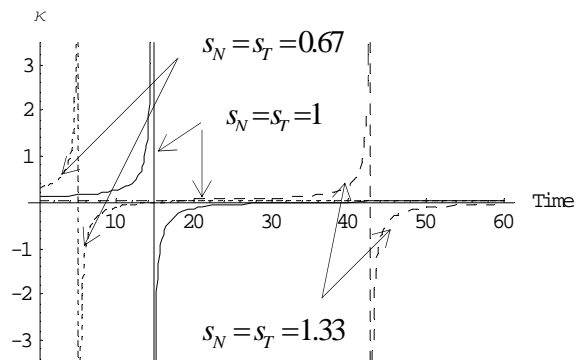

References

- Atkinson, A.B., 1969, "The Time scale of economic models: How long is the long run?" *Review of Economic Studies* 36, 137-152.
- Balassa, B., 1964, "The purchasing power parity doctrine: A reappraisal," *Journal of Political Economy* 72, 584-596.
- Bergin, P.R and R.C. Feenstra, 2001, "Pricing-to-market, staggered contracts, and real exchange rate persistence," *Journal of International Economics* 54, 333-59.
- Betts, C. and M.B. Devereux, 2000, "Exchange rate dynamics in a model of pricing-to-market," *Journal of International Economics* 50, 215-244.
- Brock, P.L. and S.J. Turnovsky, 1994, The dependent economy model with both traded and nontraded capital goods, *Review of International Economics* 2, 306-325.
- Caselli, F., 2003, "The missing input: Accounting for cross-country income differences," in P. Aghion and S. Durlauf (eds.), *Handbook of Economic Growth*, Elsevier, Amsterdam (forthcoming).
- Chari, V.V, P.J. Kehoe, and E. McGrattan, 2002, "Can sticky price models generate volatile and persistent real exchange rates?" *Review of Economic Studies* 69, 533-63.
- Cheung, Y.W. and Lai, K.S., 2000, "On cross-country differences in the persistence of real exchange rates," *Journal of International Economics* 50, 375-397.
- Dixit, A. and R. Rob, 1994, "Switching costs and sectoral adjustments in general equilibrium with uninsured markets," *Journal of Economic Theory* 62, 48-69.
- Duffy, J. and C. Papageorgiou, 2000, "A cross-country empirical investigation of the aggregate production function specification," *Journal of Economic Growth* 5, 87-120.
- Edwards, S., and M.A. Savastano, 1999, "Exchange rates in emerging economies: What do we know? What do we need to know?" NBER Working Paper 7228.
- Eicher, T.S. and S.J. Turnovsky, 1999, "Convergence in a two-sector nonscale growth model," *Journal of Economic Growth* 4, 413-328
- Fogel, R.W., 1964, *Railroads and American Economic Growth: Essays in Econometric History*, Johns Hopkins University Press, Baltimore MD.

- Froot, K. A. and K. Rogoff, 1995, "Perspectives on PPP and long-run real exchange rates," In: Grossman, G., Rogoff, K. (eds.), *Handbook of International Economics, vol III*, North Holland, Amsterdam.
- Gavin, M., 1990, "Structural adjustment to a terms of trade disturbance: The role of relative price." *Journal of International Economics* 28, 217-243.
- Gavin, M., 1992, "Income effects of adjustment to a terms of trade disturbance and the demand for adjustment finance," *Journal of Development Economics* 37, 127-153.
- Grossman, G. M., 1983, "Partially mobile capital: A general approach to two-sector trade theory," *Journal of International Economics* 15, 1-17.
- Hayashi, F., 1982, "Tobin's marginal q, average q: A Neoclassical interpretation," *Econometrica* 50, 213-224.
- Kaldor, M. and G. Schmeder, (Eds.), 1997, *The European Rupture, the Defence Sector in Transition*, Edward Elgar, Cheltenham, UK.
- Kiss, Y., 1997, "The former Czechoslovakia," In M. Kaldor and G. Schmeder, (Eds.), *The European Rupture, the Defence Sector in Transition*, Edward Elgar, Cheltenham, UK.
- Morshed, A.K.M. and S.J. Turnovsky, 2004, "Sectoral adjustment costs and real exchange rate dynamics in a two-sector dependent economy," *Journal of International Economics* 63, 147-177.
- Mussa, M., 1978, "Dynamic adjustment in the Heckscher-Ohlin-Samuelson model," *Journal of Political Economy* 86, 775-791.
- Obstfeld, M. and K. Rogoff, 1995, "Exchange rate dynamics redux," *Journal of Political Economy* 103, 624-660.
- Obstfeld and Rogoff, 2001, "The six major puzzles in international macroeconomics: Is there a common cause?" *NBER Macroeconomics Annual, 2000*, 339-390.
- Ramanathan, R., 1973, "Adjustment time in the two-sector growth model with fixed coefficients," *Economic Journal* 83, 1236-1244.
- Salter, W.E.G., 1959, "Internal and external balance: The role of price and expenditure effects," *Economic Record* 35, 226-238.

- Samuelson, P.A., 1964, "Theoretical notes on trade problems," *Review of Economics and Statistics* 46, 145-164.
- Sato, R., 1963, "Fiscal policy in a neoclassical growth model: An analysis of the time required for equilibrating adjustment," *Review of Economic Studies*, 30, 16-23.
- Steigum, E. and O. Thørgesen, 2003, "Borrow and adjust: Fiscal policy and sectoral adjustment in an open economy," *International Economic Review* 44, 699-724.
- Swan, T.W., 1960, "Economic control in a dependent economy," *Economic Record* 36, 51-66.
- Turnovsky, S.J., 1997. *International Macroeconomic Dynamics*, MIT Press, Cambridge MA.
- Turnovsky, S.J., 2002, "Intertemporal and intratemporal substitution, and the speed of convergence in the neoclassical growth model," *Journal of Economic Dynamics and Control* 26, 2002, 1765-1785.
- Turnovsky, S.J. and P. Sen, 1995, "Investment in a two-sector dependent economy," *Journal of Japanese and International Economies* 9, 29-55.